

AMIAD Water Systems Ltd.

Filtomat M100

Model: M104CL

| | |
|--------------------|-------|
| Serial number: | _____ |
| Order number: | _____ |
| Catalogue number: | _____ |
| Filtration degree: | _____ |
| Tested by: | _____ |

Installation, Operation and Maintenance Instructions



Ref: 910101-000859 / 02.2022

Original Instructions

AMIAD Water Systems Ltd.

Filtomat M104CL - Electronically-Controlled

This document is the user-manual of the Filtomat M100 Electronic Controller Series. It describes the installation, the operation and the maintenance procedures of the M104CL filter.



Disclaimer:

Copyright © 2018 Amiad Water Systems Ltd. All rights reserved.

The contents of this document, including without limitation all information and materials, images, illustrations, data, drawings, names and any other such materials that appear in this document are the sole property of Amiad Water Systems Ltd., including any intellectual property rights, whether registered or not, and all know-how contained or embodied therein. Amiad may alter, remove or change the Content without any further notice. You may not reproduce, copy, modify, create derivative works from, sell or participate in any sale of, or exploit in any way, in whole or in part, any of this document or its content.

The confidential nature of and/or privilege in the file enclosed is not waived or lost as a result of a mistake or error in this file. If you received this file in error, please notify Amiad immediately at info@amiad.com.

This document does not replace any certified drawing, procedure or information provided by Amiad in reference to a specific customer, site or project.

Amiad assumes that all users understand risks involved within this file and/or its attached materials. This document is given in good faith and is not intended to impose any obligation to Amiad. While every effort has been made to ensure the information in this manual is accurate and complete, we would appreciate if you can bring any errors or omissions to the knowledge of Amiad or consult Amiad experts or its authorized representatives if you have any questions.

Amiad Water Systems Ltd. D.N. Galil Elyon 1, 1233500, Israel Tel: 972 4 690 9500 | Fax: 972 4 814 1159 Email: info@amiad.com

TABLE OF CONTENTS

| | |
|---|----|
| Specifications | 4 |
| Safety Instructions | 5 |
| General Safety Instructions | 5 |
| Installation | 5 |
| Commissioning | 6 |
| Operation and Control | 6 |
| Maintenance | 7 |
| Dimensional Drawing | 8 |
| Introduction | 9 |
| General Description | 9 |
| Self-Cleaning Cycle | 10 |
| Installation | 11 |
| Design Recommendations | 11 |
| Preparations for Installation | 11 |
| Installation Procedure | 11 |
| IMPORTANT!! | 11 |
| Preparations | 12 |
| Getting Started | 12 |
| First operation of filter | 12 |
| Maintenance | 13 |
| Checking the Filter | 13 |
| Winterization | 13 |
| Servicing | 14 |
| Draining the Filter | 14 |
| Removing and Installing the Screen | 14 |
| Servicing the Suction Scanner | 16 |
| Servicing the Piston | 18 |
| Parts Schedule #1 & #2 | 19 |
| Parts Drawing #1 | 20 |
| Parts Drawing #2 | 21 |
| Parts Schedule #3 | 22 |
| Parts Drawing #3 | 23 |
| Parts Schedule #4 | 24 |
| Parts Drawing #4 | 24 |
| Amiad Limited Warranty | 25 |

With any inquiry please quote the Filter Serial Number, located on the filter housing.

Specifications

General

| | | |
|--------------------------|---------------------------------------|---|
| Maximum flow rate | 100 (m ³ /h) - 440 (USgpm) | Consult manufacturer for optimum flow. |
| Min. working pressure | 2.0 (bar) 30 (psi) | Or lower if pressure is increased for flushing. |
| Max. working pressure | 8 (bar) 115 (psi) | |
| Filtration area | Total Filtration area | 3000 (cm ²) 465 (in ²) |
| | Net Filtration area | 2,250 (cm ²) 349 (in ²) |
| Inlet/Outlet diameter | 100 (mm) 4" | Flange standards as per request. |
| Max. working temperature | 55°C; 130°F | |
| Weight (Empty) | 50 kg 110 lb | |

Flush data

| | | |
|---------------------------|--|-----------------------------------|
| Exhaust valve | 40 (mm) 1 1/2" | |
| Flushing cycle time | 10 seconds | Depending on the working pressure |
| Wasted water per cycle | 28 (liters) 7.3 (US gallon) | at 2 (bar) 30 (psi) |
| Minimum flow for flushing | 20 (m ³ /h) 88 (USgpm) | at 2 (bar) 30 (psi) |
| Flush criteria | Differential pressure of 0.5 bar; 7 psi and manual operation | |

Construction materials

| | |
|--------------------|---|
| Filter housing | Epoxy-coated carbon steel 37-2 (St. St. 316 available on request) |
| Filter lid | Epoxy-coated carbon steel 37-2 (stainless steel 316L on request) high density polypropylene |
| Coarse screen | Reinforced nylon |
| Fine screen | Stainless Steel 316, molded plastic support structure |
| Cleaning mechanism | PVC and Stainless Steel 316L |
| Motor assembly | Reinforced nylon, brass, stainless steel |
| Control tubing | Polyethylene |
| Seals | BUNA-N |
| Control | Brass, Stainless Steel 316, PVC, Acetal |

Filtration degrees available

| | | | | | | |
|--------|---------------|-----|-----|------|-----|------|
| Type | Molded screen | | | | | |
| Micron | 500 | 300 | 200 | 130 | 100 | 80 |
| mm | 0.5 | 0.3 | 0.2 | 0.13 | 0.1 | 0.08 |

Safety Instructions

General Safety Instructions

- Amiad filtration products always operate as components in a larger system. It is essential for the system designers, installers and operators to comply with all the relevant safety standards.
- Prior to installation, operation, maintenance or any other type of action carried out on the filter, read carefully the safety, installation and operation instructions.
- During installation, operation or maintenance of the filter all conventional safety instructions should be observed in order to avoid danger to the workers, the public or to property in the vicinity.
- Please note: The filter enters into a flushing mode automatically, without prior warning.
- No change or modification to the equipment is permitted without a written notification given in advance by the manufacturer or by its representative, on the manufacturer's behalf.
- Always observe standard safety instructions and good engineering practices whilst working in the filter's vicinity.
- Use the filter only for its intended use as designed by Amiad, any misuse of the filter may lead to undesired damage and may affect your warranty coverage. Please consult with Amiad prior to any non-regular use of this equipment.

Installation

General

- Install the filter according to the detailed Installation Instructions provided with the filter by the manufacturer and according to the description given in this manual.
- Make sure to leave enough clearance so as to enable easy access for future treatments and safe maintenance operations.
- The user should arrange suitable lighting at the area of the filter to enable good visibility and safe maintenance.
- The user should arrange suitable platforms, ladders and safety barriers to enable easy and safe access to the filter without climbing on pipes and other equipment. The user should verify that any platform, barrier, ladder or other such equipment is built, installed and used in accordance with the relevant local authorized standards.
- Check and re-tighten all bolts during commissioning and after the first week of operation.
- Use only appropriate standard tools and equipment operated by qualified operators when installing, operating and maintaining the filter.
- When installation is required in hazardous environment sites, underground or high above ground, make sure that the site design and the auxiliary equipment are appropriate and that installation procedures are carried out in accordance with the relevant standards and regulations.
- Ensure walking areas about the installation are slip free when wet.

Shipment and transporting

- Shipping and transporting the filter must be done in a safe and stable manner and in accordance with the relevant standards and regulations.
- For shipping, lifting and positioning the filter, use only approved lifting equipment and authorized employees and contractors.

Electricity

- Electric wiring should be performed by an authorized electrician only, using standardized and approved components.
- Install a **lockable** main power cut-off switch close to the control panel.
- If due to site constraints, the control panel is installed without a clear line-of sight of the filter, an additional **lockable** power disconnect cut-off switch should be installed near each filter unit.
- Installation of the filter should be performed so as to avoid direct water splashing on the electrical components or on the control panel.

Pneumatics

- Install a **lockable** main cut-off switch, **featured with a pressure release mechanism**, on the compressed air supply line close to the control panel.
- If the control panel is installed far away and there is no eye contact with the filter, a **lockable** compressed air cut-off switch, **featured with a pressure release mechanism**, should be installed near each filter unit.
- The user should make sure that the compressed air supplied to the filter never exceeds the maximum designated pressure for this filter. An air-pressure reduction valve should be installed on the compressed air supply line upstream of the filter's pneumatic inlet port.

Hydraulics

- Extra safety devices should be installed on hot water applications to avoid skin burn danger.
- The user should install a manual Water Cut-off Valve next to the filter's inlet port.
- In cases where the downstream piping network downstream of the filter is pressurized an additional manual Water Cut-off Valve should be installed next to the filter outlet port.
- The user should make sure that the system includes a Pressure Release / Drainage Valve to enable release of residual pressure prior to any maintenance procedure performed on the filter.
- The user should make sure that the filter is never exposed to water pressure exceeding the maximum designated pressure for this filter, if needed a Pressure Reduction Valve should be installed upstream of the filter's water inlet port.
- Please note that the maximum working pressure indicated at the filter's specifications table includes the pressure caused by fluid hammer and pressure surge effects.

Civil Engineering

- Make sure that the filter installation is done by Amiad qualified technicians.
- Make sure that any civil engineering work at the installation site such as construction, lifting, welding, etc. is done by qualified workers / technicians / contractors and in accordance with the relevant local standards.
- While using lifting equipment, make sure that the filter or the lifted part is chained securely and in a safe manner.
- Do not leave lifted equipment if there is no necessity. Avoid working below lifted equipment.
- Wear a safety helmet while using lifting equipment.
- Make sure that the flooring is sloped for drainage and to avoid accumulation of liquids.

Commissioning

- Read carefully the Commissioning and the First Start-up Operation instructions prior to any attempt to operate the filter.
- In order to achieve maximum performance and smooth operation of the filter it is crucial to perform the Startup and First Operation procedures exactly as described in this manual.
- Commissioning the filter should be done by an authorized Amiad technician, do not attempt to commission the filter unaccompanied since this may lead to undesired damage and may affect your warranty coverage.

Operation and Control

- Do not operate the filter before reading carefully and being familiar with its operation instructions.
- Observe the safety stickers on the filter and never perform any operation contradicting the instructions given.
- Never operate or use the filter for purposes other than its original design and operational envelope.

Maintenance

Before any maintenance or non-regular operation please read the following:

- Servicing the filter should be done only by technicians authorized by Amiad.
- Disconnect the filter from the power supply and lock the Main Power Switch.
- Disconnect the compressed air supply, release the residual pressure and lock the Pneumatics Main Valve.
- Disconnect the filter from the water system by closing and securing the Manual Inlet Valve. In cases where the downstream piping network is pressurized, close and secure the Manual Outlet Valve also.
- Release the residual water pressure by opening the Pressure Release / Drainage Valve.
- Empty the filter by opening the Drainage Valve.
- In hot water systems wait till the filter components cool off to a safe temperature.
- Place warning signs around the work area as required by the local standards and procedures.
- Inspect the filter's safety stickers and replace any damaged or faded sticker.

Mechanical

- When working on the filter use only appropriate standard tools.
- Always open and close valves slowly and gradually.
- Remove grease and fat material residues in order to avoid slipping.
- Before disconnecting the filter from the water supply, electricity and pneumatics and before releasing the filter's residual pressure do NOT:
 - loosen or unscrew bolts
 - remove any protection cover
 - open any service port flange
- Avoid splashing and water leakage so as to minimize slippage, electrification or damage to the equipment, caused by moisture.
- While using lifting equipment, make sure that the filter or the lifted part is chained securely and in a safe manner.
- Do not leave lifted equipment if there is no necessity. Avoid working below lifted equipment.
- Wear a safety helmet, goggles, gloves, and any other personal safety equipment required by the local standards and regulations.
- Human entry into a filter must be done in accordance with the relevant local safety instructions, standards and regulations for working in hazardous environment.
- Manual cleaning of filter media using high water pressure or steam should be performed in accordance with the cleaning system instructions, the local standards and regulations and without endangering the operator or the vicinity
- Manual cleaning of filter element using acid or other chemical agents should be performed in accordance with the relevant material safety instructions, the local standards and regulations and without endangering the operator or his vicinity.

Before returning to regular operation

- Re-assemble any protection covers or protection mechanisms removed during service or maintenance operations.
- Make sure that all the tools, ladders, lifting devices, etc. used during the maintenance procedures are taken away from the filter area and stored
- In order to return the filter to regular operation, follow the First Start-up Operation instructions as detailed in your user manual.
- For filters used in potable water systems it is required to disinfect the filter according to the local water authority standards and regulations before putting it back to service.

Dimensional Drawing

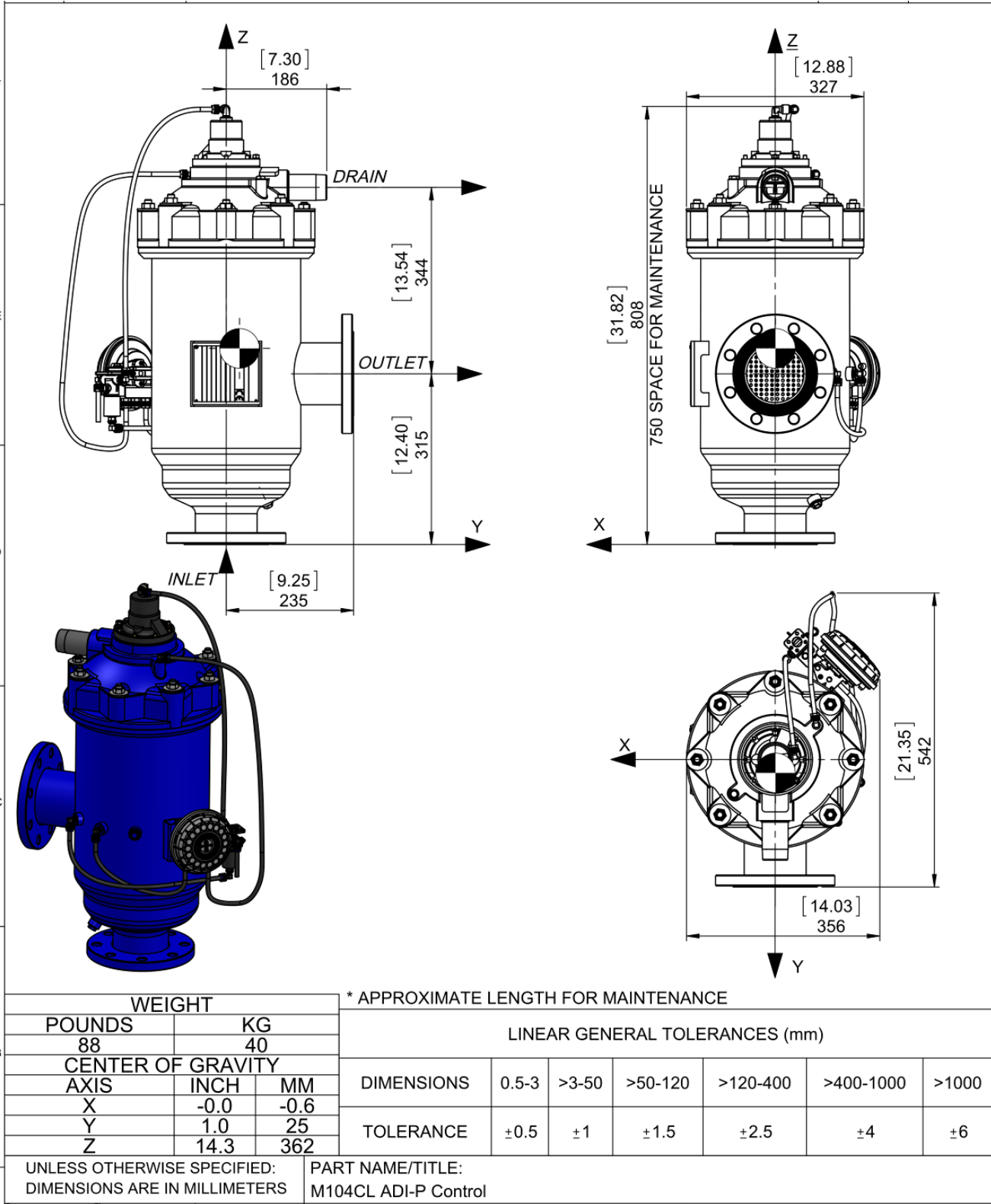

Introduction

The **FILTOMAT M100** is a sophisticated, yet easy-to-operate automatic filter, with a self-cleaning mechanism driven by a hydraulic turbine. The **FILTOMAT M100** is designed to work with various types of screens with filtration degrees from 500 to 80 micron, and is available in 3" and 4" inlet/outlet diameter.

The **FILTOMAT M100** filters are configured to meet your specific needs according to flow rates and water quality. These filters can be installed as stand-alone units for low flow rates, or assembled in a group on a manifold when high flow rates and/or a large screen area are required. The filters are delivered fully assembled, requiring a simple connection to the inlet and outlet and to the exhaust.

General Description

Water enters the filter through the inlet pipe and passes through a coarse screen which is designed to protect the cleaning mechanism from large dirt particles. It should not accumulate large quantities of suspended solids and is not cleaned automatically. The water then flows through a fine screen that filters out the smaller particles. Clean water then flows from the filter through the outlet. The particles form a "filtration cake" which accumulates on the fine screen surface. The cake build-up increases the pressure differential across the fine screen, and at a pre-set value of 0.5 bar (7psi) the automatic self-cleaning cycle begins. Suction nozzles sweep across the surface of the fine screen pulling debris off and expelling it out of the exhaust valve.

This innovative self-cleaning process, utilizes the backflush technique to effectively remove the dirt particles from the fine screen, and provide an uninterrupted downstream flow during the self-cleaning cycle.

Self-Cleaning Cycle

The automatic self-cleaning cycle described below takes several seconds and does not interrupt the supply of process water.

Water flows from the inlet through the coarse and fine screens to the outlet. At a pre-set pressure differential (0.5 bar; 7 psi), the controller opens the exhaust valve. The pressure in the rotor chamber drops, releasing a strong backflush stream that flows through the nozzles and then out the exhaust.

The drop in pressure and corresponding release of the back flush stream creates a suction at the nozzle tips. This effect actuates spot cleaning directly in front of the openings of each nozzle on the inner surface of the fine screen.

Backflush water flows through the collector pipe, via the rotor to the exhaust valve forcing the dirt collector assembly to spin. The first backflush stroke begins when the pressure-drop in the rotor chamber permits the suction scanner assembly to move upward.

When the first stroke is completed, the exhaust valve closes and after a very short interval the rinse controller activates the second backflush stroke (downward). The dirt collector assembly moves downward returning to its original position.

The two stroke helical movement of the dirt collector assembly as described ensures that the nozzles sweep the entire inner surface of the fine screen.

This self-cleaning process takes approx. 10 seconds, depending on the operating pressure.

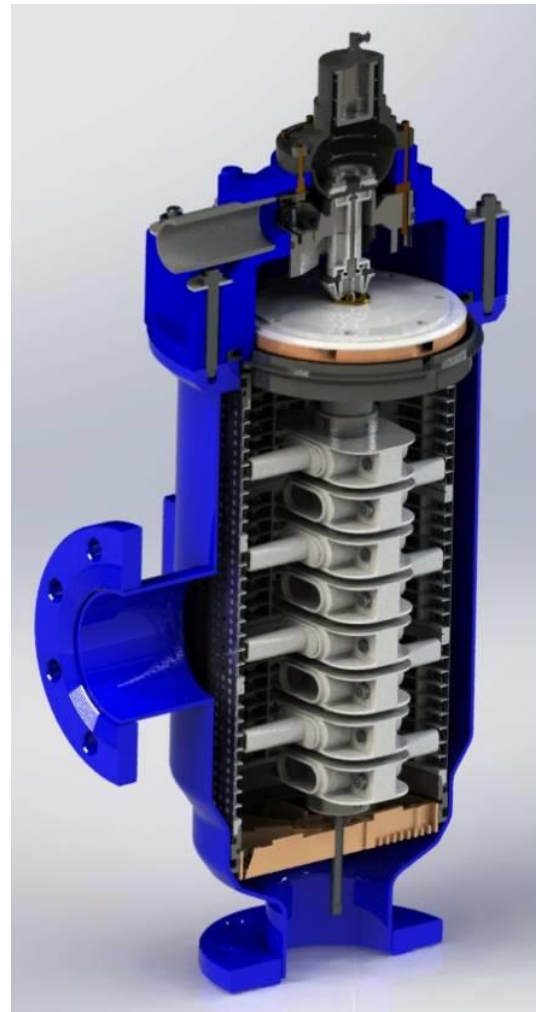
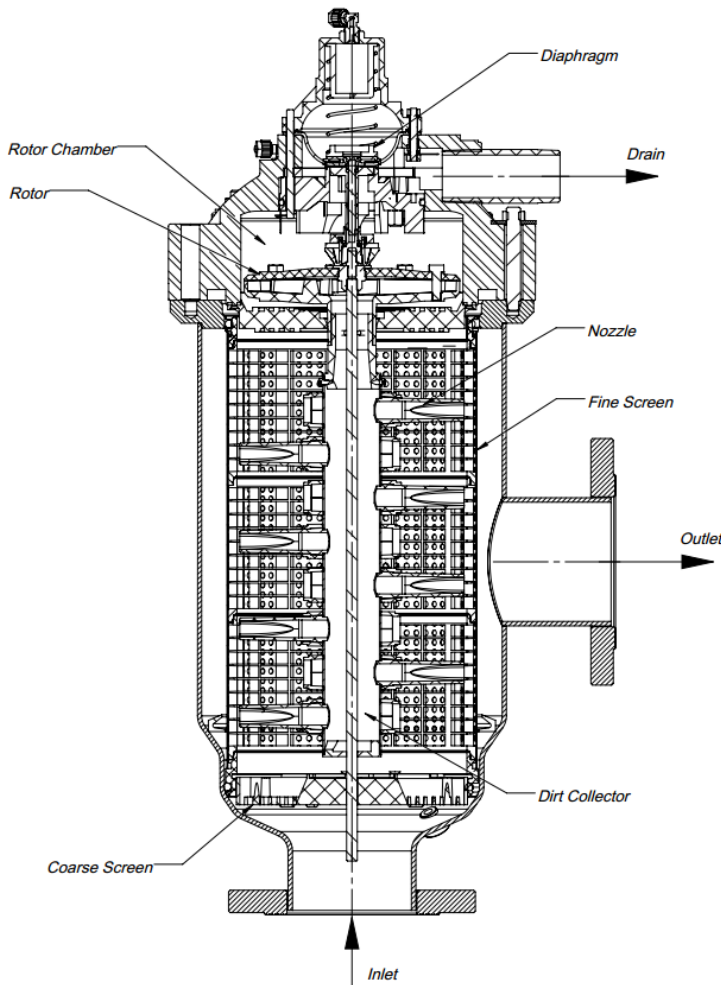

Installation

Read these instructions carefully before installing and operating the filter.

Design Recommendations

- If a prolonged pipeline fill time causes a temporary high flow and low pressure condition, it is recommended that you install a pressure sustaining valve downstream of the filter. The pressure-sustaining valve will ensure a controlled fill-up of the line.
- The upstream pressure source should not drop below 2 bar (30 psi) during the rinse cycle. If this cannot be ensured, consult the manufacturer.
- If continued water delivery is essential even during “down time” maintenance periods, it is recommended that a manual or automatic by-pass be installed, and that isolating valves be installed up and downstream of each filter unit for isolation purposes.
- Avoid placing the drainage pipe on a rising slope to minimize backpressure.
- Secure the open end of the drain pipe to prevent movement during the rinse cycle.
- It is recommended to install a mechanical non-return valve downstream of the filter.
- It is recommended to install a pressure gauge on the three-way valve.
- Check that there is sufficient space to remove the cover assembly and the screen from the filter for troubleshooting.

Preparations for Installation

- Ensure suitable lighting at the area of the filter to enable good visibility and safe maintenance.
- Arrange suitable platforms and safety barriers to enable easy, safe access to the filter.
- It is recommended to install a mechanical non-return valve downstream of the filter to prevent backflow damage to the screen.
- Allow a convenient approach and enough space for dismantling and maintenance.

Installation Procedure

Ensure the direction of flow according to the arrows marked on the filter housing.

1. Connect a minimum of 2" (50mm) pipe to the exhaust valve. The exhaust pipe should be designed so that it creates minimal resistance to flow of 20m³/h (88USgpm). Water should be allowed to flow to atmosphere freely from the exhaust pipe.
2. Connect a minimum of 1" (25mm) flexible tube to the rinse controller drain port. Ensure this drain line is open to atmosphere.

IMPORTANT!!

- **Prevent static back pressure or reverse flow through the filter.**
- **Install a manual or a hydraulic valve downstream of the filter.**

NOTE: The filter may enter flush mode automatically, without prior warning.

Preparations

Before using the filter for the first time, go through the following check-list carefully. No special training is required to carry out these activities.

- Check that the upstream pressure at the filter inlet is more than 2 bar (30 psi) during the flushing cycle.
- Check that the filter is mounted in the correct flow direction.
- Check that all the control tubes are connected properly and that all connections are tight.
- Check that the three-way mini-valve is turned to the automatic position. The arrow on the knob should point to AUTO.
- The nominal diameter of the drainpipe should be 2" (50 mm), in order not to restrict the drain line.
- Shut the upstream and downstream isolation valves.
- Check that there is sufficient space to remove the cover assembly and the screen from the filter for troubleshooting.

Getting Started

First operation of filter

After completing the preparation check-list above, perform the following steps:

1. Slowly open the isolating valve at the filter inlet. Water will flow into the filter.
2. Check for leaks and repair if necessary.
3. Check that the minimum inlet pressure remains 2 bar (30 psi) or higher.
4. Slowly open the isolating valve at the outlet of the filter.
5. If there is a by-pass valve, close it slowly.
6. Ensure the flow through the filter does not exceed the filters published maximum flow rate.
7. Start a manual flush by turning the three-way valve to the **OPEN** position for a few seconds, and then turn it back to **AUTO**.
8. During the self-cleaning cycle, check the pressure at the filter inlet and in the rotor chamber.

NOTE: The minimum pressure in the rotor chamber should be 1.5 bar lower than the inlet pressure.

Maintenance

NOTE: Depressurize the filter before maintenance (close inlet, and then outlet valve).

Checking the Filter

1. Remove the filter cover by unscrewing the fastening nuts.
2. Extract the fine screen and clean if necessary. Cleaning may be performed by hosing the screen from outside-in, and/or with a nylon brush.
3. Check the coarse screen and clean if necessary.
4. Check the O-rings of the fine screen and apply grease, if necessary.
5. Reassemble the fine screen.

NOTE: Check that the dirt collector shaft is properly aligned in the bearing.

6. Return the cover and fasten the nuts.
7. Perform **First Operation of Filter** as on page 10.

Winterization

Filter operations should be suspended in climates where the filter is exposed to freezing temperatures.

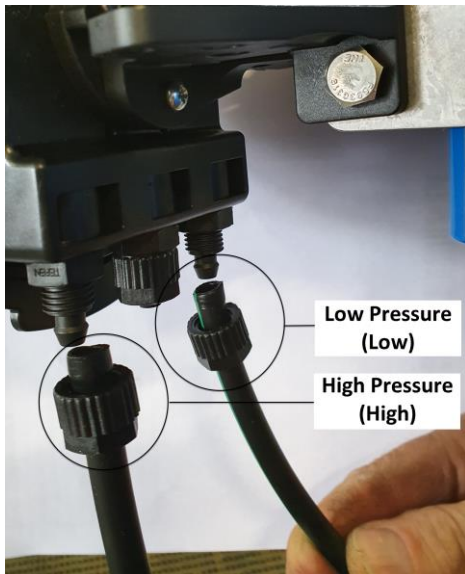

1. Check that the outlet isolating valve is closed and perform two manual rinses.
2. Close the inlet valve to the filter and release the pressure.
3. Mark the tubes that are linked to the ADI-P controller and disconnect it from the controller for the duration of the winter season.
4. Remove the following items from the filter and store in a dry place:
 - a. Top lid assembly
 - b. Coarse and fine screen assembly
5. Apply grease to the O-rings of the fine screen before storing.

At the beginning of the operation season, reassemble the filter elements and check **Preparations** (on page 10) and **First Operation of Filter** (page 10).

Servicing

NOTE: Depressurize the filter before maintenance (close inlet, and then outlet valve).

Draining the Filter

1. Close the inlet valve
2. Close the outlet valve.
3. Open the drain valve to release pressure. To avoid water draining onto the area around the filter, install a drain hose onto the drain valve.

Removing and Installing the Screen

1. Drain the filter.
2. Remove the filter cover nuts and the cover.

Removing the Cover



- Using the special tool, pull the screen out of the housing. (CAT. NO. 710103-001121- TOOL EXTRACTOR M100 S/ST304 F/FINE SCREEN)

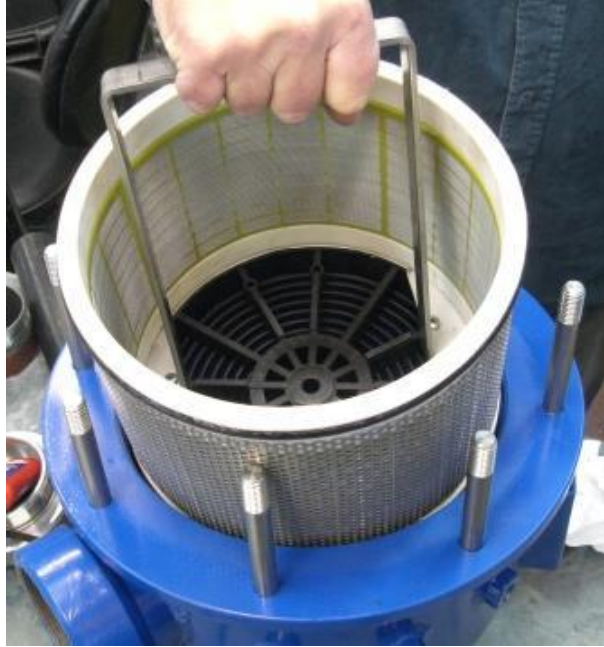

Removing the Screen

- Reinstall by lubricating O-ring seals with silicone grease and pushing the filter screen into the housing. The screen assembly should be slightly below the surface of the housing as in the figure below.



Screen Seated Properly

Servicing the Suction Scanner

1. Open the filter housing as described previously.
2. To replace a nozzle, remove the two bolts and nuts holding the nozzle and install a new nozzle, noting that the inlet of the nozzle is aligned over the outlet hole of the suction scanner tube.

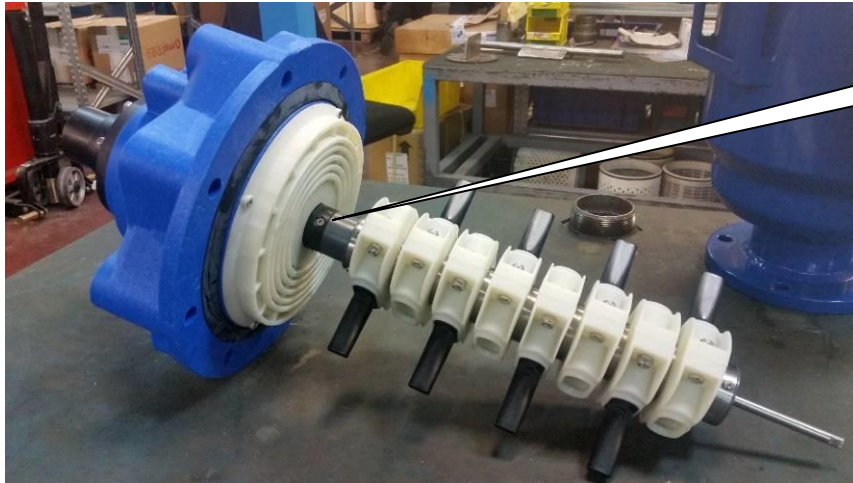

Suction Scanner

3. To replace the valve, remove the Phillips screws holding the suction scanner assembly, and remove the assembly from the housing.
4. Remove the turbine and valve assembly from the suction scanner.
5. The assembly is held together by a screw and special nut.

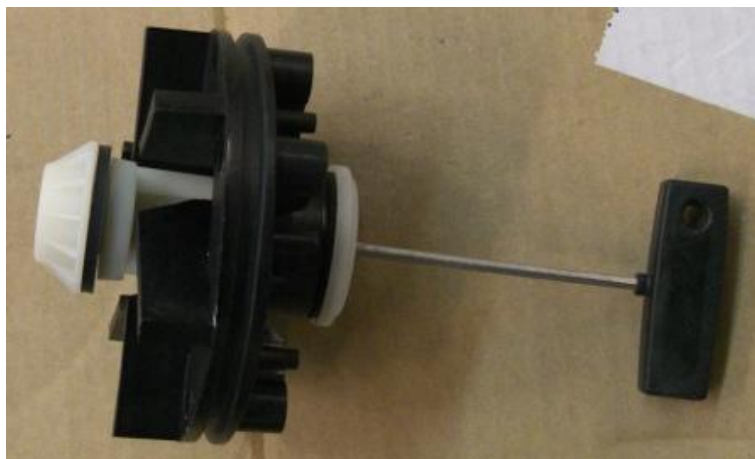

**Valve and Turbine Assembly
(shown with Allen wrench)**

6. Take care that rubber seals and valve parts face the correct direction when assembling.



Valve Parts Disassembled

7. Notice the position of the large housing cover gasket. The conical surface faces the other half of the housing.

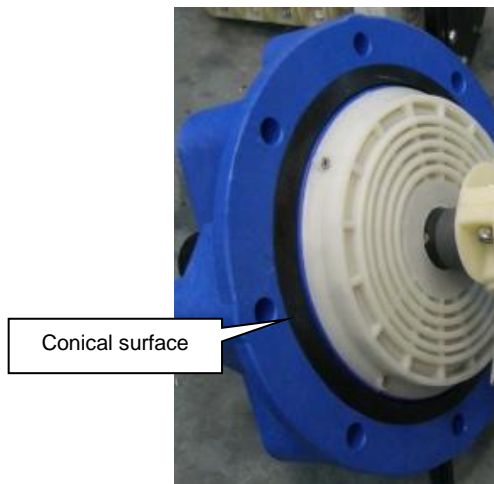

Housing Gasket

Servicing the Piston

1. Remove the nuts holding the piston housing, and carefully open the housing so that the spring doesn't jump out.



Piston Housing Open

2. Note the directions the parts face before reassembling.



Piston Assembly

Parts Schedule #1 & #2

| NO. | CAT. NO. | DESCRIPTION | QTY. | MATERIAL |
|-----|---------------|--|------|---------------|
| 1 | 710105-xxxxxx | M104CL HOUSING 4" ON-LINE PKPK 5010 ST.37-2 POLYESTER | 1 | ST.37-2 |
| 2 | 700101-002018 | MOLDED WEAWEWIRE SCREEN S/ST316L 3000SQ.CM 200MIC M100 NBR SEALS | 1 | Various |
| 2.1 | 770102-000217 | DOWTY O-RING SEAL 674 ID=208.92MM TH=6.99MM NBR 55 SHORE NO FLASH | 1 | NBR |
| 3 | 770104-000156 | HYDRAULIC SEAL NATURAL 55 SHORE LID M102-104 | 1 | NBR |
| 4 | 760101-000508 | PHILLIPS FLAT TAPPING SCREW NO.8 3/4" S/ST316 ASME B18.6.4 TYPE-AB | 4 | S/ST 316 |
| 5 | 700190-005075 | DIRT COLLECTOR ASSEMBLY 8 NOZZLE M104CL + ROTOR AND PARTS | 1 | VARIOUS |
| 6 | 700190-001727 | COVER ASSY (M102C)/3C(L)/4C | 1 | Various |
| 7 | 760104-000081 | STUD BOLT 1/2" UNC 92MM S/ST304 | 1 | S/ST 304 |
| 8 | 760104-000082 | STUD BOLT 1/2" UNC 100MM S/ST304 | 3 | S/ST 304 |
| 9 | 760104-000084 | STUD BOLT 1/2" UNC 108MM S/ST304 | 4 | S/ST 304 |
| 10 | 760103-000068 | FLAT WASHER 1/2" SPECIAL C/ST ZINC PLATED THK3MM | 8 | ST.37-2 |
| 11 | 760102-000096 | HEX JAM NUT 1/2"UNC S/ST304 B18.2.2 | 1 | S/ST 304 |
| 12 | 760102-000052 | HEX NUT 1/2"UNC C/ST ZINC PLATED B18.2.2 | 7 | Z.PLATED C/ST |
| 13 | 780101-000932 | NIPPLE 1 1/2"X105MM BSP M PVC | 1 | PVC |
| 14 | 760105-000036 | RIVET BLIND 3X6MM S/ST316 DIN7337 | 1 | S/ST 316 |
| 15 | 900103-000001 | NAMEPLATE ENGLISH ALUMINIUM FILTOMAT SELF-CLEANING FILTERS CE | 1 | Aluminum |
| 16 | 700190-005810 | ADI-P DC 1 BACSOL 12VDC 2W LATCH 8MM TEFFEN M102/3/4 C/CL ASSY | 1 | VARIOUS |
| 17 | 720501-000229 | L-CONNECTOR 1/4"M X8MM BSPT ACETAL BLACK-BLUE TEFFEN | 3 | NYLON |
| 18 | 720501-000190 | PLUG 1/4"M BSPT PA66 BLUE TEFFEN | 2 | PVC |
| 19 | 720501-000218 | L-CONNECTOR 1/4"F X1/4"M BSPT BRASS/NICKEL PLATED AIGNEP | 1 | Nickel |
| 20 | 710101-001309 | PISTON NOZZLE 1.5 MM PP GREEN | 1 | PP |
| 21 | 720502-000017 | CONTROL TUBE 8MM LDPE BLACK W/GREEN STRIPE TEFFEN | 1.5 | PA |

Parts Drawing #1

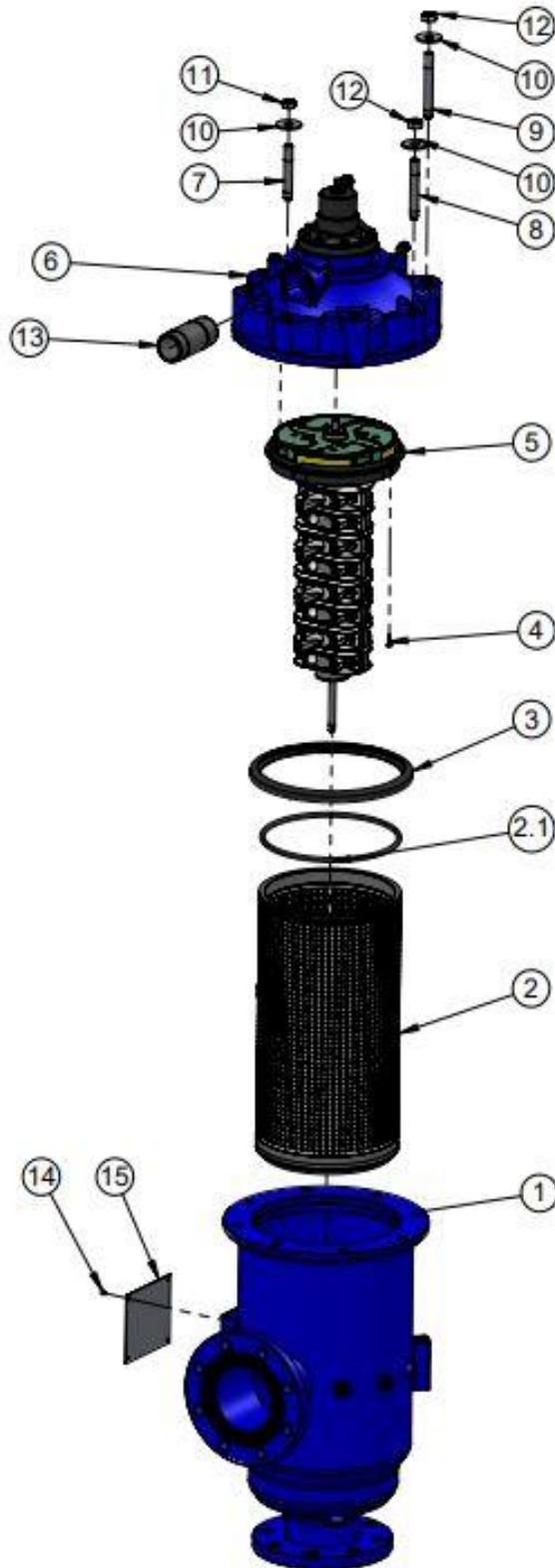

Parts Drawing #2

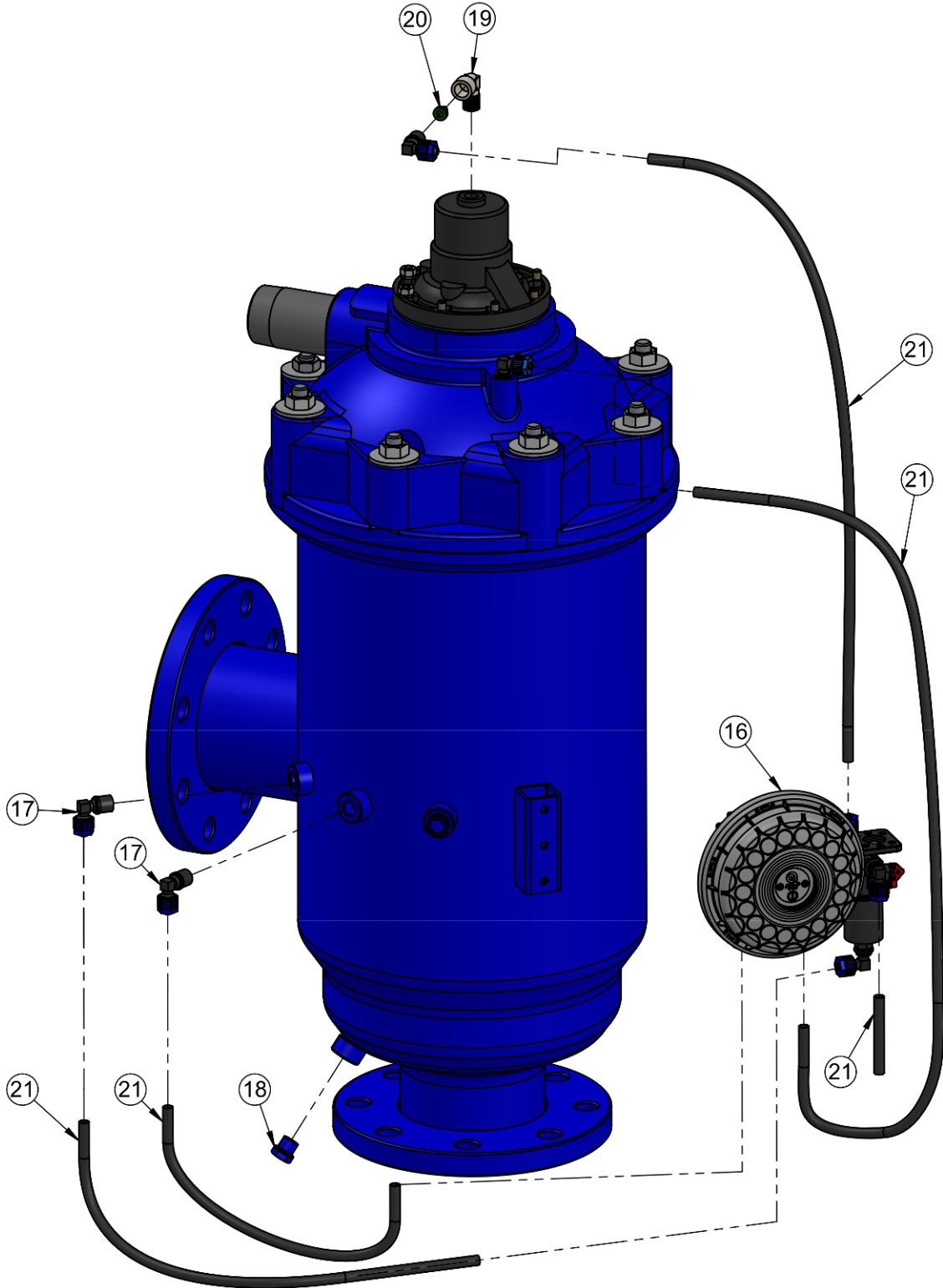

Parts Schedule #3

| NO. | CAT. NUMBER | Description | Qty. | MATERIAL |
|--------|---------------|--|------|-------------|
| 6 | 700190-001727 | Cover Assembly M102C/3C(L)/4C | 1 | Various |
| 6.1 | 710103-000816 | Cover 8 Holes M10X(X)(L) | 1 | PP |
| 6.2 | 770106-000028 | Diaphragm M102C/104C Natural Rubber | 1 | NBR |
| 6.3 | 710101-000703 | Spring Guide M102/3(B)(C) | 1 | S/ST 316L |
| 6.4 | 760107-000070 | Spring S/St302 | 1 | S/ST 302 |
| 6.5 | 710101-000702 | Plug Guide Spring M102/3 | 1 | S/ST 316L |
| 6.6 | 710103-000984 | Diaphragm Cover M102C/104C | 1 | NYLON 30%GF |
| 6.7 | 710103-001083 | Rod Tie Short Diaphragm Cover | 1 | Bronze |
| 6.8 | 710103-000896 | Bush Cover M10X(L)(P) Brass | 1 | Brass |
| 6.9 | 760102-000078 | Hex Nut 1/4"UNC S/ST316 B18.2.2 | 9 | SST316L |
| 6.1 | 700190-001741 | Exhaust Valve Assembly (102/3/4C) | 1 | Verious |
| 6.10.1 | 770104-000133 | Seal Valve M102/3C NBR | 2 | NBR |
| 6.11 | 770102-000079 | O-Ring Seal P2-107 NBR | 8 | NBR |
| 6.12 | 710103-001084 | Square Washer S/St316 (30x30) | 1 | S/ST 316L |
| 6.13 | 710103-001089 | Support Rod Tie Diafhrgm Brass M102/3(B) | 1 | Brass |
| 6.14 | 710103-001097 | Rod Tie Long Diaphragm Cover Brass | 7 | Bronze |
| 6.15 | 770102-000156 | O-Ring Seal (P2-351) 50+5 NBR | 1 | NBR |
| 6.16 | 710103-000990 | Seat Valve (Insert) | 1 | S/ST 316L |
| 6.17 | 710103-001080 | Nut Special Brass | 7 | Brass |
| 6.18 | 760103-000094 | Flat Washer M6 DIN125S/ST316 | 8 | SST316 |
| 6.19 | 770101-000042 | O-Ring Seals 6x3 Nbr "S" | 2 | NBR |
| 6.2 | 720501-000190 | Plug 1/4"M Blue | 1 | PVC |
| 6.21 | 720501-000194 | L-Connector 1/4"Mx6mm Black-Blue | 1 | PVC |
| 6.22 | 720501-000200 | L-Connector 1/4"Mx6mm Red-Blue | 1 | PVC |

Parts Drawing #3

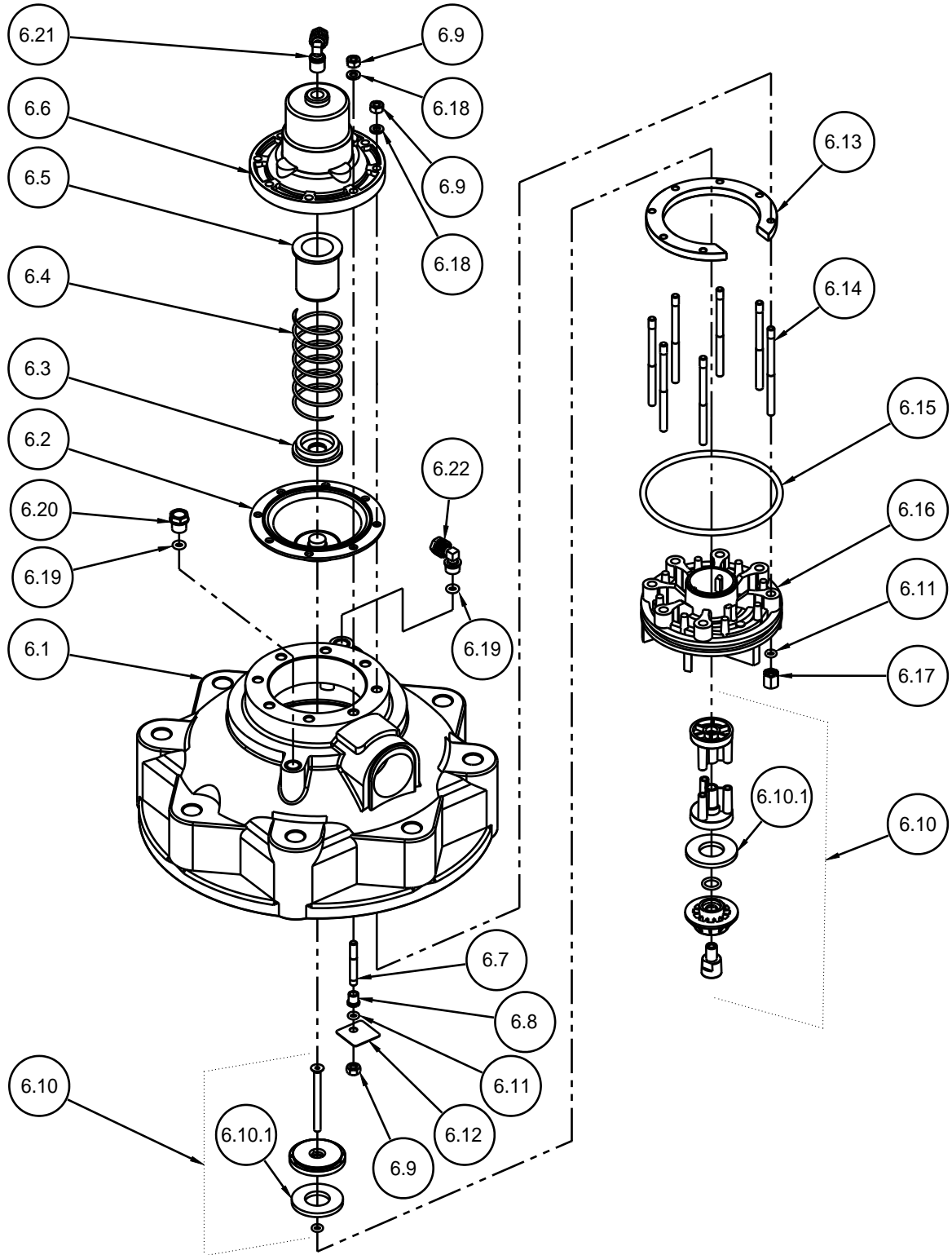

Parts Schedule #4

| | CAT. NO. | DESCRIPTION | QTY. | MATERIAL |
|------|---------------|--|------|-------------|
| 1 | 710103-009351 | BODY 52MM M104CL S/ST304 DIRT COLLECTOR 8 NOZZ | 1 | S/ST 304 |
| 2 | 710103-001113 | PLUG M103CL/4C PVC F/DIRT COLLECTOR | 1 | PVC |
| 3 | 710103-001096 | PLUG M102/3C PVC F/DIRT COLLECTOR | 1 | PVC |
| 4 | 710101-000704 | F100 SUCTION NOZZLE OVAL RPA BLACK | 4 | NYLON |
| 5 | 710101-000693 | F100 CLIP RPA NATURAL | 8 | NYLON 30%GF |
| 6 | 710103-000986 | SERIRS 100 | 1 | RPA6+33%GF |
| 7 | 710103-009352 | SHAFT DIRT COLLECTOR 3/8" M104CL S/ST303 THR M | 1 | S/ST 303 |
| 8 | 760101-000417 | HEX BOLT PARTIAL TH 1/4"UNCX1 1/4" 304 | 8 | S/ST 304 |
| 9 | 760102-000097 | NYLON INSERT LOCKNUT 1/4"UNC S/ST316 DIN985 | 8 | S/ST 316 |
| 10 | 760101-000688 | PHILLIPS PAN TAP SCREW #8X3/8" S/ST316 | 6 | S/ST 316 |
| 11 | 760101-000689 | PHILLIPS FLAT TAP SCREW #8X5/8" 304 | 4 | S/ST 304 |
| 12 | 710101-001637 | M100 TURBINE BELL RPP BLACK | 1 | VARIOUS |
| 12.1 | 710103-011978 | BEARING M100 S/ST316 | 1 | S/ST316L |

Parts Drawing #4

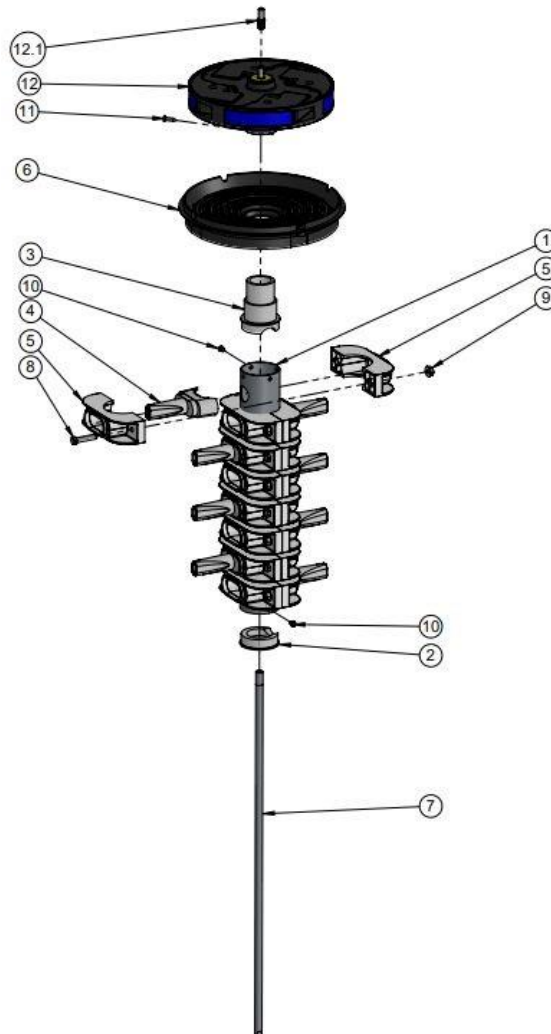

Amiad Limited Warranty

1. This certificate applies to Amiad Water Systems Ltd. ("**Amiad**") products purchased by you (the "**Buyer**") from Amiad unless specifically agreed otherwise in writing by Amiad. This Warranty extends only to the original purchaser, and is not transferable to anyone who subsequently purchases, leases, or otherwise obtains the product from the original purchaser.
2. Amiad hereby warrants that the products are and will be free from defects in material and workmanship under normal use and service. Amiad warrants that it will correct manufacturing defects in the products, in accordance with the conditions set out in this Warranty.
3. This Warranty is enforceable for a period of 12 months after the date upon which the products were delivered (the "**Warranty Period**").
4. In the event that during the Warranty Period the Buyer discovers a defect in material and/or workmanship in any product or part (the "**Defective Product**"), it shall submit a written complaint to Amiad using Amiad's standard Buyer Complaint Form. For the receipt of the Buyer Complaint Form, the submission of the complaint or any questions please contact your service representative.
5. Upon written demand by Amiad the Buyer shall return the Defective Product - or a sample thereof - to Amiad, at Amiad's cost. If the Buyer ships any such Defective Product, Amiad suggests the Buyer package it securely and insure it for value, as Amiad assumes no liability for any loss or damage occurring during shipment. Provided however that in the event Amiad determines that this Warranty does not apply to such product, Buyer shall promptly reimburse Amiad for such cost (including freight and customs). Any returned product or part must be accompanied by the Warranty certificate and the purchase invoice. It is clarified that the Buyer may not return the Defective Product unless such return was coordinated and approved by Amiad in advance.
6. Amiad's obligation under this Warranty shall be limited to, at Amiad's option, the repair or exchange, free of charge, of the product or any part which may prove defective under normal use and service during the Warranty Period. The provision of a repair or replacement of a product during the Warranty Period will result in an extension of the Warranty Period by an additional period of 12 months, provided that the total accumulated Warranty Period shall in any event be no more than 18 months from the date upon which the products were delivered.
7. This Warranty is valid on the condition that the products are installed according to Amiad's instructions as expressed in Amiad's instruction manuals and according to the technical limitations as stipulated in Amiad's literature or as stated by a representative of Amiad.
8. This Warranty will not apply to damaged or defective products resulting from or related to:
 - (i) Fire, flood, power surges or failures or any other catastrophe and/or unforeseen occurrence, such as but not limited to those for which the Buyer is customarily insured for, or any force majeure events;
 - (ii) Fault, abuse or negligence of the Buyer;
 - (iii) Intake water not meeting the agreed standards, as set forth in a written document, approved by Amiad, or improper storage;
 - (iv) Improper or unauthorized use of the product or related parts by the Buyer, including Buyer's failure to operate the product in conformity with the recommendations and instructions of Amiad, as set forth in Amiad's manuals and other written materials, the operation of the product other than by a trained and qualified operator, or improper installation of the product by a third party not authorized by Amiad;
 - (v) Performance by the Buyer of maintenance or operation other than in conformity with the recommendations and instructions of Amiad, or other than in accordance with procedures defined in the literature supplied for products (including the timely replacement of requisite parts), and for services provided other than by a trained and qualified advanced operator; or
 - (vi) Any alteration, modification, foreign attachment to or repair of the products, other than by Amiad or its authorized technical representatives.
9. In no event shall Amiad be liable to the Buyer or any third party for any damages to property, or for any intangible or economic loss, including loss of profits, loss of customers or damage to reputation, for any damages, including indirect, special, consequential damages, or punitive damage arising out of or in connection with this Warranty, or arising out of or in connection with the product's performance or failure to perform, even if it has been advised of the possibility of such damages.
10. Amiad will be excused for failure to perform or for delay in performance hereunder if such failure or delay is due to causes beyond its reasonable control or force majeure preventing or hindering performance.
11. This Warranty set forth herein is the only contractual warranty given by Amiad and is provided in lieu of any other warranties created by any documentation, packaging or otherwise.
12. Amiad makes no warranty whatsoever in respect to accessories or parts not supplied by Amiad. In the event that Amiad is required to correct a Defective Product or product not covered by this Warranty, it will do so solely in consideration for additional fees.
13. The parties will actively endeavor to amicably settle any dispute arising between them. In the event that the parties are unable to reach an equitable settlement of such dispute, any claim or lawsuit related to the Warranty, its validity execution, its performance be brought before only the courts of Tel-Aviv, Israel. Israeli law will govern the Warranty, to the exclusion of any conflict of law rules.



Manufacturer

Amiad Water Systems Ltd. D.N. Galil Elyon 1, 1233500, Israel.
Tel: +972 4690 9500 | Fax: +972 48141159 | Email: info@amiad.com

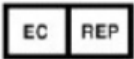

European Authorised Representative for CE

Obelis s.a. Bd Général Wahis 53, 1030 Brussels, Belgium.
Tel: +(32) 2732 5954 | Fax: +(32) 27326003 | Email: mail@obelis.net

EC Declaration https://www.amiad.com/certificatesDownload_CE.asp