

# OMEGA Filters

## Installation & Operation Manual



### OMEGA 27K & 36K

<b>Standard Models</b>	Ref. 910101-000880
<b>Date</b>	02.2017

NOTICE: This document contains Amiad Confidential Information. Copying and distributing this document are strictly prohibited



## Table of contents

1. Cover Page
2. Disclaimer
3. Safety Instructions
4. Technical Specifications
5. Drawings
6. Description of Filter Operation
7. Control Philosophy
8. Installation Instructions
9. Commissioning, Start-up and First Operation
10. Part Schedule
11. Maintenance
12. Troubleshooting
13. Amiad Limited Warranty
14. Appendices

## Disclaimer

Copyright © 2017 Amiad Water Systems Ltd. All rights reserved.

The contents of this document, including without limitation all information and materials, images, illustrations, data, drawings, names and any other such materials that appear in this document are the sole property of Amiad Water Systems Ltd., including any intellectual property rights, whether registered or not, and all know-how contained or embodied therein. Amiad may alter, remove or change the Content without any further notice. You may not reproduce, copy, modify, create derivative works from, sell or participate in any sale of, or exploit in any way, in whole or in part, any of this document or its content.

The confidential nature of and/or privilege in the file enclosed is not waived or lost as a result of a mistake or error in this file. If you received this file in error, please notify Amiad immediately at [info@amiad.com](mailto:info@amiad.com).

This document does not replace any certified drawing, procedure or information provided by Amiad in reference to a specific customer, site or project.

Amiad assumes that all users understand risks involved within this file and/or its attached materials. This document is given in good faith and is not intended to impose any obligation to Amiad. While every effort has been made to ensure the information in this manual is accurate and complete, we would appreciate if you can bring any errors or omissions to the knowledge of Amiad or consult Amiad experts or its authorized representatives if you have any questions.

Amiad Water Systems Ltd. D.N. Galil Elyon 1, 1233500, Israel Tel: 972 4 690 9500 | Fax: 972 4 814 1159 Email: [info@amiad.com](mailto:info@amiad.com)

## **3. Safety Instructions**

***Applicable local or national safety regulations and rules for the prevention of accidents must be applied in all work procedures in addition to the following instructions.***

## **a. General Safety Instructions**

- Amiad filtration products always operate as components in a larger system. It is essential for the system designers, installers and operators to comply with all the relevant safety standards.
- Prior to installation, operation, maintenance or any other type of action carried out on the filter, read carefully the safety, installation and operation instructions.
- During installation, operation or maintenance of the filter all conventional safety instructions should be observed in order to avoid danger to the workers, the public or to property in the vicinity.
- Please note: The filter enters into a flushing mode automatically, without prior warning.
- No change or modification to the equipment is permitted without a written notification given in advance by the manufacturer or by its representative, on the manufacturer's behalf.
- Always observe standard safety instructions and good engineering practices whilst working in the filter's vicinity.
- Use the filter only for its intended use as designed by Amiad, any misuse of the filter may lead to undesired damage and may affect your warranty coverage. Please consult with Amiad prior to any non-regular use of this equipment.

## **b. Installation**

- Install the filter according to the detailed Installation Instructions provided with the filter by the manufacturer and according to the description given in this manual.
- Make sure to leave enough clearance so as to enable easy access for future treatments and safe maintenance operations.
- The user should arrange suitable lighting at the area of the filter to enable good visibility and safe maintenance.
- The user should arrange suitable platforms, ladders and safety barriers to enable easy and safe access to the filter without climbing on pipes and other equipment. The user should verify that any platform, barrier, ladder or other such equipment is built, installed and used in accordance with the relevant local authorized standards.
- Check and re-tighten all bolts during commissioning and after the first week of operation.
- Use only appropriate standard tools and equipment operated by qualified operators when installing, operating and maintaining the filter.
- When installation is required in hazardous environment sites, underground or high above ground, make sure that the site design and the auxiliary equipment are appropriate and that installation procedures are carried out in accordance with the relevant standards and regulations.
- Ensure walking areas about the installation are slip free when wet.

## **c. Shipment and Transporting**

- Shipping and transporting the filter must be done in a safe and stable manner and in accordance with the relevant standards and regulations.
- For shipping, lifting and positioning the filter, use only approved lifting equipment and authorized employees and contractors.

## d. Electricity

- Electric wiring should be performed by an authorized electrician only, using standardized and approved components.
- Install a lockable main power cut-off switch close to the control panel.
- If due to site constraints, the control panel is installed without a clear line-of sight of the filter, an additional lockable power disconnect cut-off switch should be installed near each filter unit.
- Installation of the filter should be performed so as to avoid direct water splashing on the electrical components or on the control panel.

## e. Pneumatics

- Install a lockable main cut-off switch, featured with a pressure release mechanism, on the compressed air supply line close to the control panel.
- If the control panel is installed far away and there is no eye contact with the filter, a lockable compressed air cut-off switch, featured with a pressure release mechanism, should be installed near each filter unit.
- The user should make sure that the compressed air supplied to the filter never exceeds the maximum designated pressure for this filter. An air-pressure reduction valve should be installed on the compressed air supply line upstream of the filter's pneumatic inlet port.

## f. Hydraulics

- Extra safety devices should be installed on hot water applications to avoid skin burn danger.
- The user should install a manual Water Cut-off Valve next to the filter's inlet port.
- In cases where the downstream piping network downstream of the filter is pressurized an additional manual Water Cut-off Valve should be installed next to the filter outlet port.
- The user should make sure that the system includes a Pressure Release / Drainage Valve to enable release of residual pressure prior to any maintenance procedure performed on the filter.
- The user should make sure that the filter is never exposed to water pressure exceeding the maximum designated pressure for this filter, if needed a Pressure Reduction Valve should be installed upstream of the filter's water inlet port.
- Please note that the maximum working pressure indicated at the filter's specifications table includes the pressure caused by fluid hammer and pressure surge effects.

## g. Civil Engineering

- Make sure that the filter installation is done by Amiad qualified technicians.
- Make sure that any civil engineering work at the installation site such as construction, lifting, welding, etc. is done by qualified workers / technicians / contractors and in accordance with the relevant local standards.
- While using lifting equipment, make sure that the filter or the lifted part is chained securely and in a safe manner.
- Do not leave lifted equipment if there is no necessity. Avoid working below lifted equipment.
- Wear a safety helmet while using lifting equipment.
- Make sure that the flooring is sloped for drainage and to avoid accumulation of liquids.

## h. Commissioning

- Read carefully the Commissioning and the First Start-up Operation instructions prior to any attempt to operate the filter.
- In order to achieve maximum performance and smooth operation of the filter it is crucial to perform the Startup and First Operation procedures exactly as described in this manual.
- Commissioning the filter should be done by an authorized Amiad technician, do not attempt to commission the filter unaccompanied since this may lead to undesired damage and may affect your warranty coverage.

## i. Operation and Control

- Do not operate the filter before reading carefully and being familiar with its operation instructions.
- Observe the safety stickers on the filter and never perform any operation contradicting the instructions given.
- Never operate or use the filter for purposes other than its original design and operational envelope.

## j. Maintenance

**Before any maintenance or non-regular operation please read the following:**

- Servicing the filter should be done only by technicians authorized by Amiad.
- Disconnect the filter from the power supply and lock the Main Power Switch.
- Disconnect the compressed air supply, release the residual pressure and lock the Pneumatics Main Valve.
- Disconnect the filter from the water system by closing and securing the Manual Inlet Valve. In cases where the downstream piping network is pressurized, close and secure the Manual Outlet Valve also.
- Release the residual water pressure by opening the Pressure Release / Drainage Valve.
- Empty the filter by opening the Drainage Valve.
- In hot water systems wait till the filter components cool off to a safe temperature.
- Place warning signs around the work area as required by the local standards and procedures.
- Inspect the filter's safety stickers and replace any damaged or faded sticker.



## k. Mechanical

- When working on the filter use only appropriate standard tools.
- Always open and close valves slowly and gradually.
- Remove grease and fat material residues in order to avoid slipping.
- Before disconnecting the filter from the water supply, electricity and pneumatics and before releasing the filter's residual pressure do NOT:
  - loosen or unscrew bolts
  - remove any protection cover
  - open any service port flange
- Avoid splashing and water leakage so as to minimize slippage, electrification or damage to the equipment, caused by moisture.
- While using lifting equipment, make sure that the filter or the lifted part is chained securely and in a safe manner.
- Do not leave lifted equipment if there is no necessity. Avoid working below lifted equipment.
- Wear a safety helmet, goggles, gloves, and any other personal safety equipment required by the local standards and regulations.
- Human entry into a filter must be done in accordance with the relevant local safety instructions, standards and regulations for working in hazardous environment.
- Manual cleaning of filter media using high water pressure or steam should be performed in accordance with the cleaning system instructions, the local standards and regulations and without endangering the operator or the vicinity
- Manual cleaning of filter element using acid or other chemical agents should be performed in accordance with the relevant material safety instructions, the local standards and regulations and without endangering the operator or his vicinity.

## l. Before Returning to Regular Operation

- Re-assemble any protection covers or protection mechanisms removed during service or maintenance operations.
- Make sure that all the tools, ladders, lifting devices, etc. used during the maintenance procedures are taken away from the filter area and stored
- In order to return the filter to regular operation, follow the First Start-up Operation instructions as detailed in your user manual.
- For filters used in potable water systems it is required to disinfect the filter according to the local water authority standards and regulations before putting it back to service.

## **4. Technical Specifications**

### a. Project Information

Project Name		
Omega Filter Model	Omega 27K	Omega 36K
Filter Catalog Number		
Quantity		
Manufacturer Serial Number		
Service		
Tag Number		
Production Date		

### b. General

Max. Operating flow rate	1,100 m <sup>3</sup> /hr (4,850 gpm)	1,500 m <sup>3</sup> /hr (6,600 gpm)
Operating pressure Min. / Max.	2.0 bar (30 psi) / 10.0 bar (150 psi)	
Design Pressure	10.0 bar (150 psi)	
Design Temperature	60°C (140°F)	
Design Code		
Filtration Element:	XXX micron	
Filter area	6 X 0.45 m <sup>2</sup> = 2.70 m <sup>2</sup>	6 X 0.60 m <sup>2</sup> = 3.60 m <sup>2</sup>
Inlet/Outlet diameter	DN250 – DN400 (10" – 16")	
Filter housing	762mm (30")	
Weight: empty/Operation	1380kg (3042lb)/2030kg (4475lb)	1560kg (3439lb)/2520kg (5556lb)

### c. Flushing Data

Exhaust valve	DN100 (4")	DN150 (6")
Flushing cycle time	15 – 25 Seconds	
Reject water volume per flush cycle	420 liter (110 gallon)	550 liter (145 gallon)
Minimum flow for flushing	60 m <sup>3</sup> /hr (264 gpm)	80 m <sup>3</sup> /hr (352 gpm)

### d. Control AND Electricity

Control voltage	24 VDC
Electric motor	0.75 kW
Rated operation Voltage	3 phase, 230/400/460 VAC 50/60 HZ
Current consumption	1.9A

### e. Construction Materials

Filter Housing & Lid	Epoxy coated fabricated carbon steel
Shell & Nozzle-Flanges	Epoxy coated fabricated carbon steel
Nozzle-Neck	Epoxy coated fabricated carbon steel
Screens	St.St. 316L
Cleaning mechanism	St.St. 316L and polymeric materials

### f. Standard Filtration Degrees

		Stainless Steel Weave-wire Screen									
micron	500	300	200	130	100	80	50	40	30	10	
mm	0.5	0.3	0.2	0.13	0.1	0.08	0.05	0.04	0.03	0.01	

## 5. Drawings

**a. GA Drawing**

**b. P&ID**

**c. System drawings**

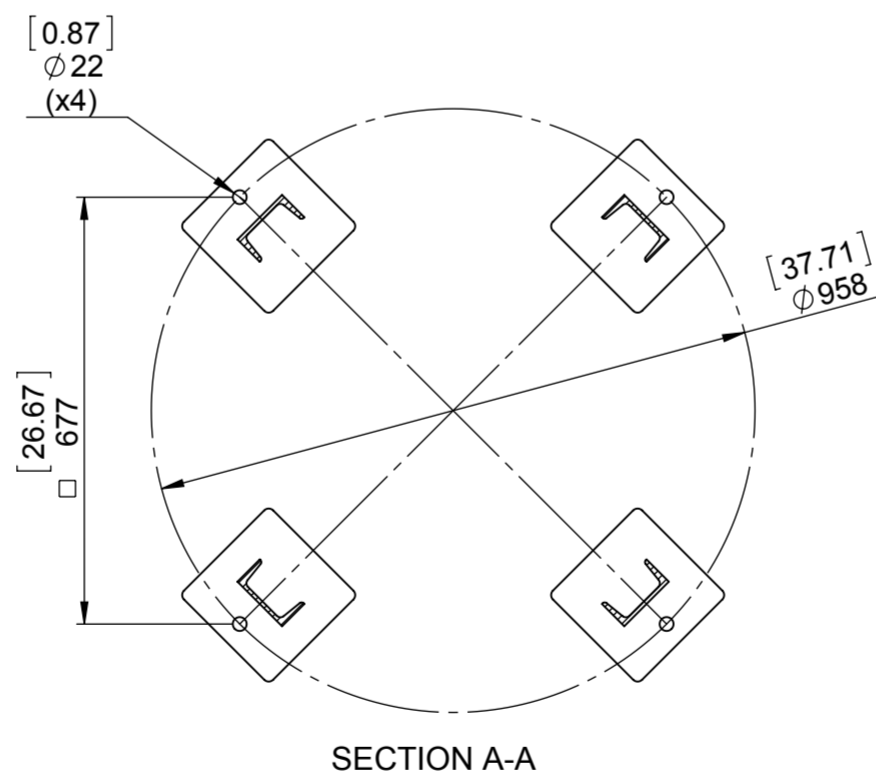
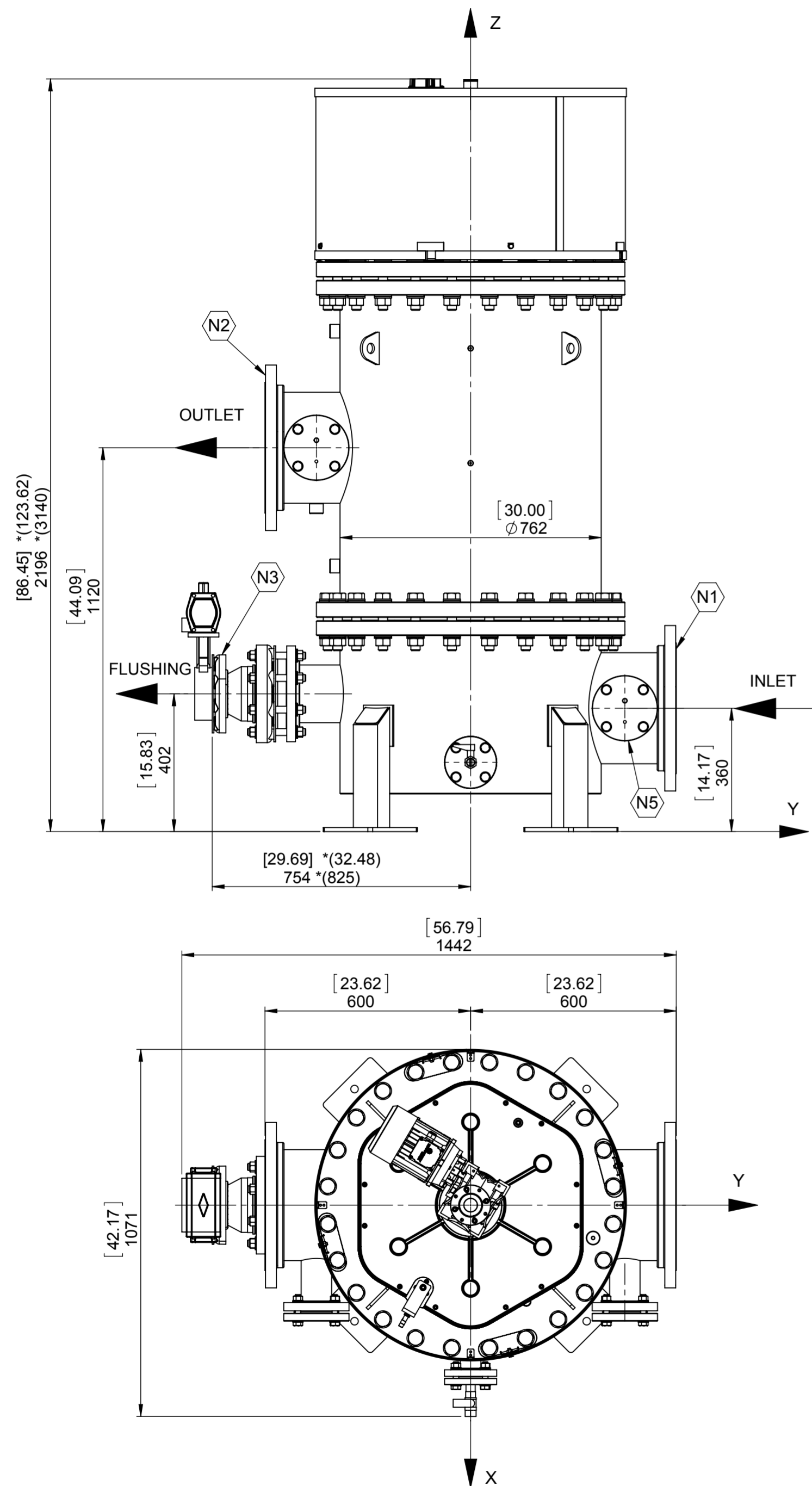

\*APPROX. LENGTH FOR MAINTENANCE  
DIMENSIONS ARE IN MM [INCH]

NOZZLES LIST

CODE	QTY.	DN	CLASS	PIPE	FLANGE TYPE	SERVICE
N1	1	12"	BY DEMAND	VARY	S.O.R.F	INLET
N2	1	12"	BY DEMAND		S.O.R.F	OUTLET
N3	1	4"	BY DEMAND		SPECIAL FF	FLUSHING
N4	1	2"	BY DEMAND		S.O.R.F	DRAINAGE
N5	2	3"	#150		S.O.R.F	INSTRUMENTATION

FOR INFORMATION ONLY

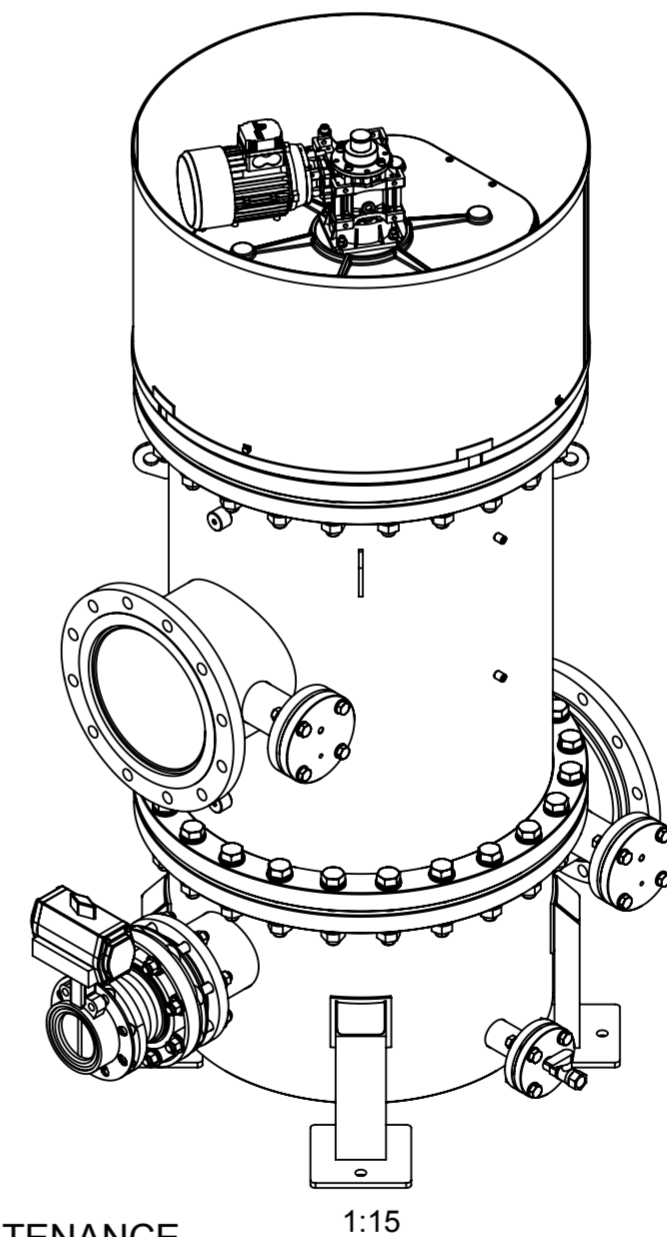

CONSTRUCTION

Materials For Filter Vessel  
Housing/ Lid: S235JR, SA106B

Flanges: See Class

DESIGN CRITERIA

Design Code	AD-2000
Design Pressure	10 Bar [145 psi]
Test Pressure	15 Bar [218 psi]
Design Temperature	50°C [122° F]
Volume	647 L [170.9 gallon]

TOTAL WEIGHT

	KG	LB
Empty	1350	2976
Operating	1997	4403
Lid (without accessories)	207	457

CENTER OF GRAVITY mm [Inch]

	X	Y	Z
Empty	6 [0.24]	-12 [-0.47]	975 [38.39]
Operating	4 [0.16]	-10 [-0.39]	960 [37.8]

Date	Reason for Issue	By	Chk	Apr
0 10/08/2015	FIRST ISSUE	J.N.	I.Z.	I.Z.

REVISION



PROJECT: 12" OMEGA-II 27K Filter AD2000 S

TITLE:  
12" OMEGA-II 27K Filter AD2000 S

IMO No.	CLASS I.D.	SCALE (A2)	REV
		1:12	0

Drw. No : QP-0454

SHEET NO.1 OF 1

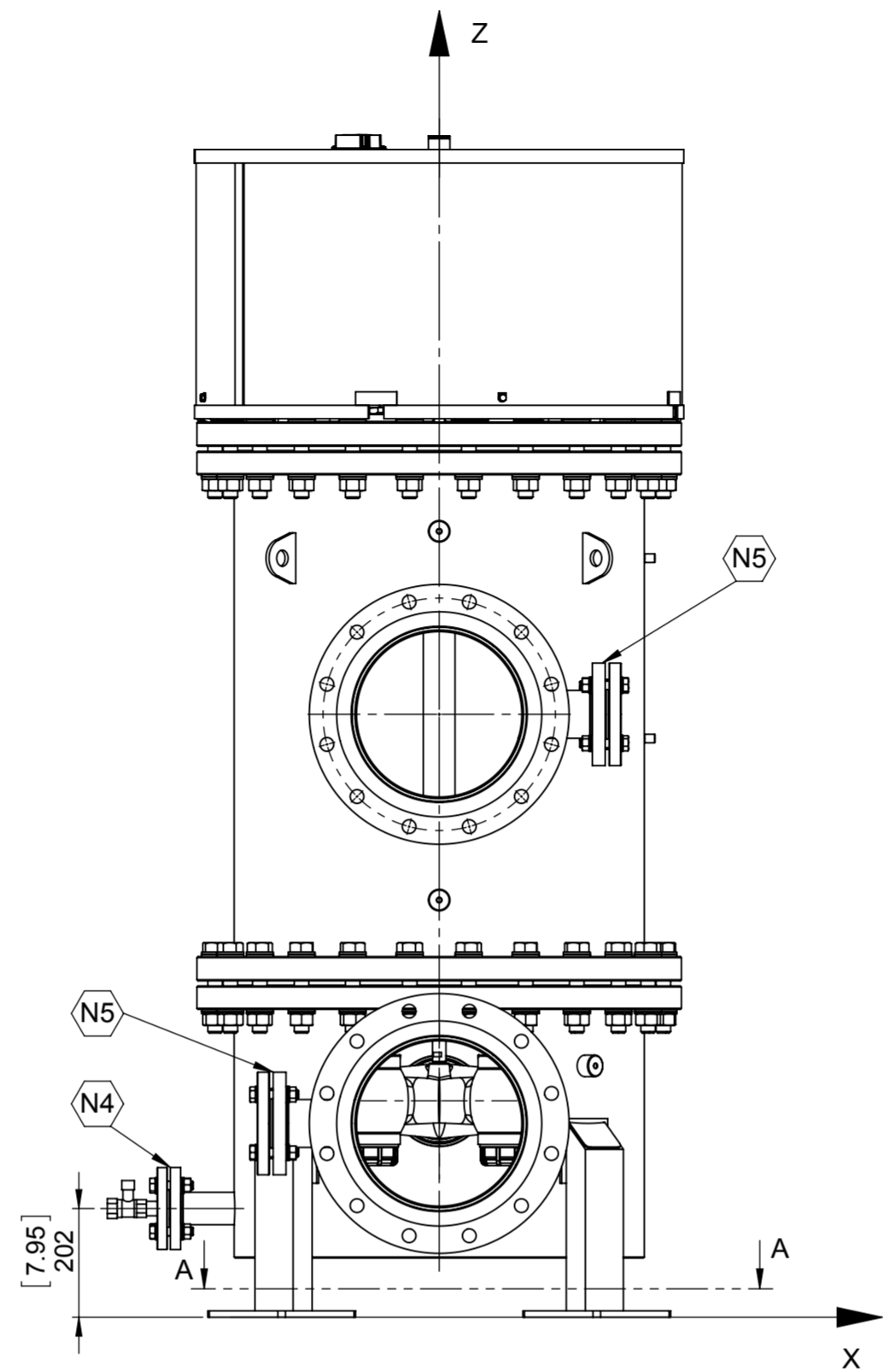
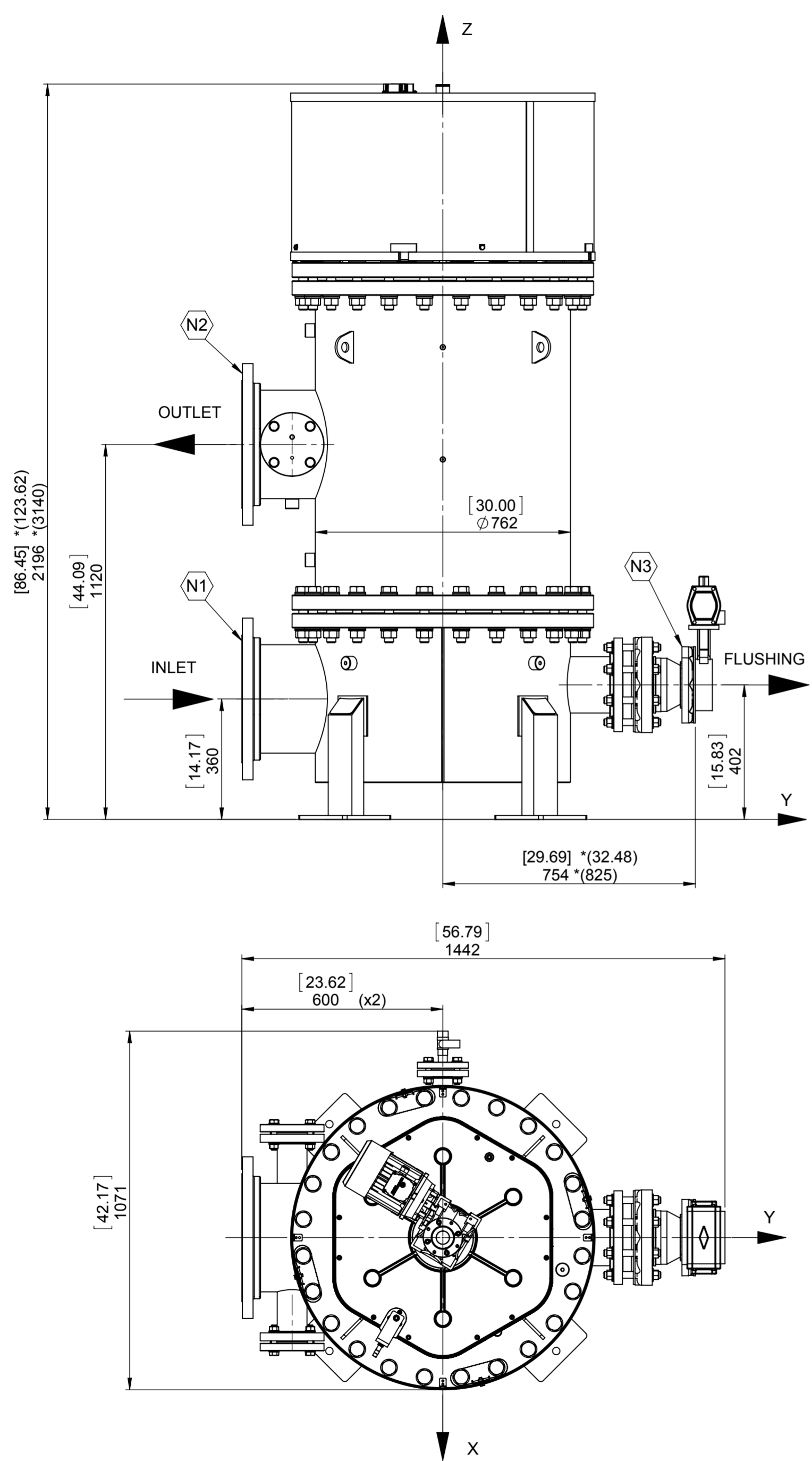

**FOR INFORMATION ONLY**

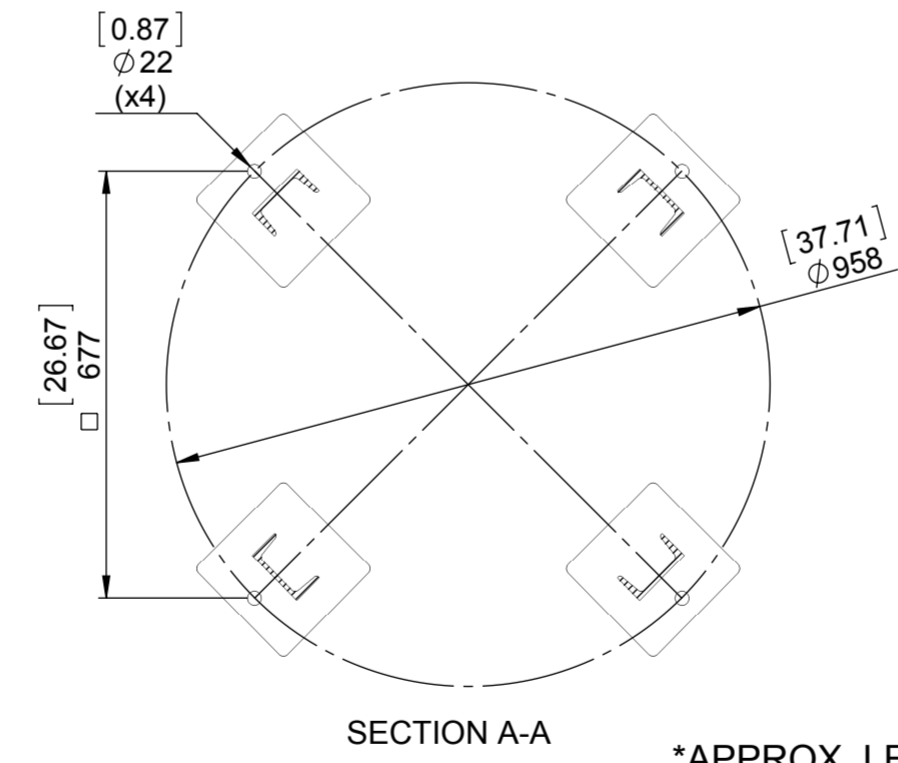
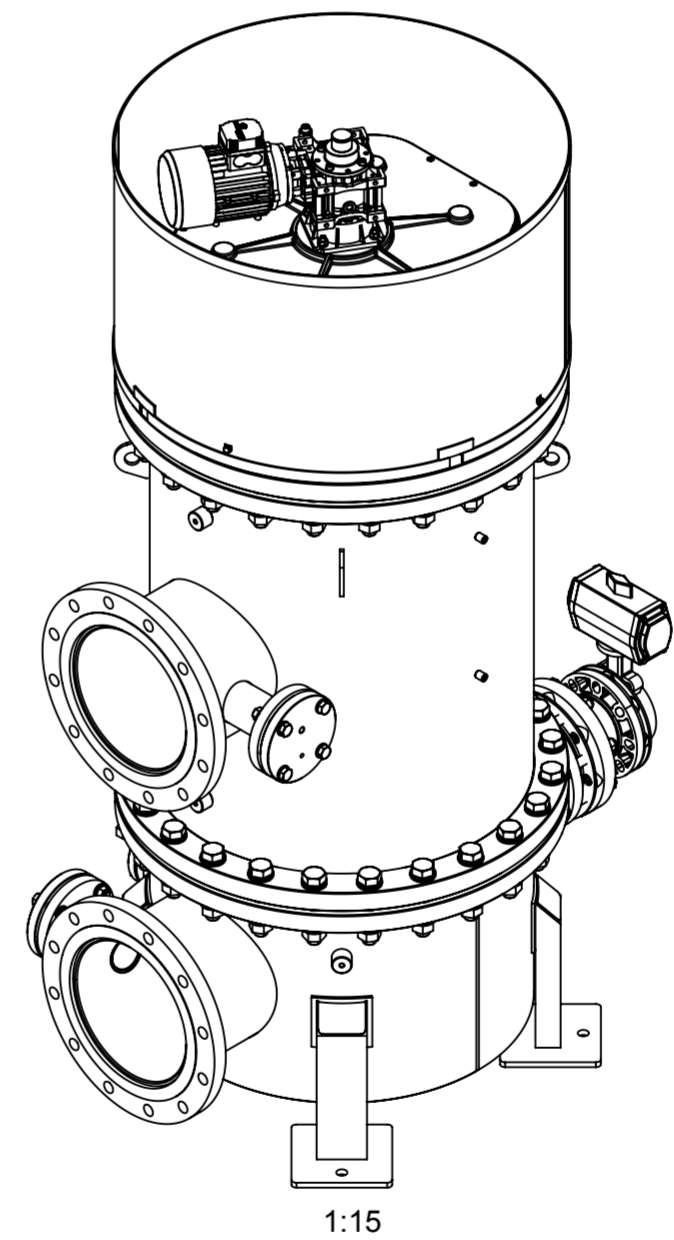

\*APPROX. LENGTH FOR MAINTENANCE  
DIMENSIONS ARE IN MM [INCH]

NOZZLES LIST						
CODE	QTY.	DN	CLASS	PIPE	FLANGE TYPE	SERVICE
N1	1	12"	BY DEMAND	VARY	S.O.R.F	INLET
N2	1	12"	BY DEMAND		S.O.R.F	OUTLET
N3	1	4"	BY DEMAND		SPECIAL FF	FLUSHING
N4	1	2"	BY DEMAND		S.O.R.F	DRAINAGE
N5	2	3"	#150		S.O.R.F	INSTRUMENTATION

CONSTRUCTION			
Materials For Filter Vessel			
Housing/ Lid: S235JR, SA106B			
Flanges: See Class			
DESIGN CRITERIA			
Design Code	AD-2000		
Design Pressure	10 Bar [145 psi]		
Test Pressure	15 Bar [218 psi]		
Design Temperature	50°C [122° F]		
Volume	647 L [170.9 gallon]		
TOTAL WEIGHT			
	KG	LB	
Empty	1350	2976	
Operating	1997	4403	
Lid (without accessories)	207	457	
CENTER OF GRAVITY mm [Inch]			
	X	Y	Z
Empty	-4 [-0.16]	-31 [-1.22]	975 [38.39]
Operating	-2 [-0.08]	-25 [-0.98]	960 [37.8]

0	19/08/2015	FIRST ISSUE	J.N.	I.Z.	I.Z.
	Date	Reason for Issue	By	Chk	Apr



PROJECT : 12" OMEGA-II 27K Filter AD2000 S  
TITLE : 12" OMEGA-II 27K Filter AD2000 S

IMO No.	CLASS I.D.	SCALE (A2)	REV
		1:12	0

Drw. No : QP-0455 SHEET NO.1 OF 1

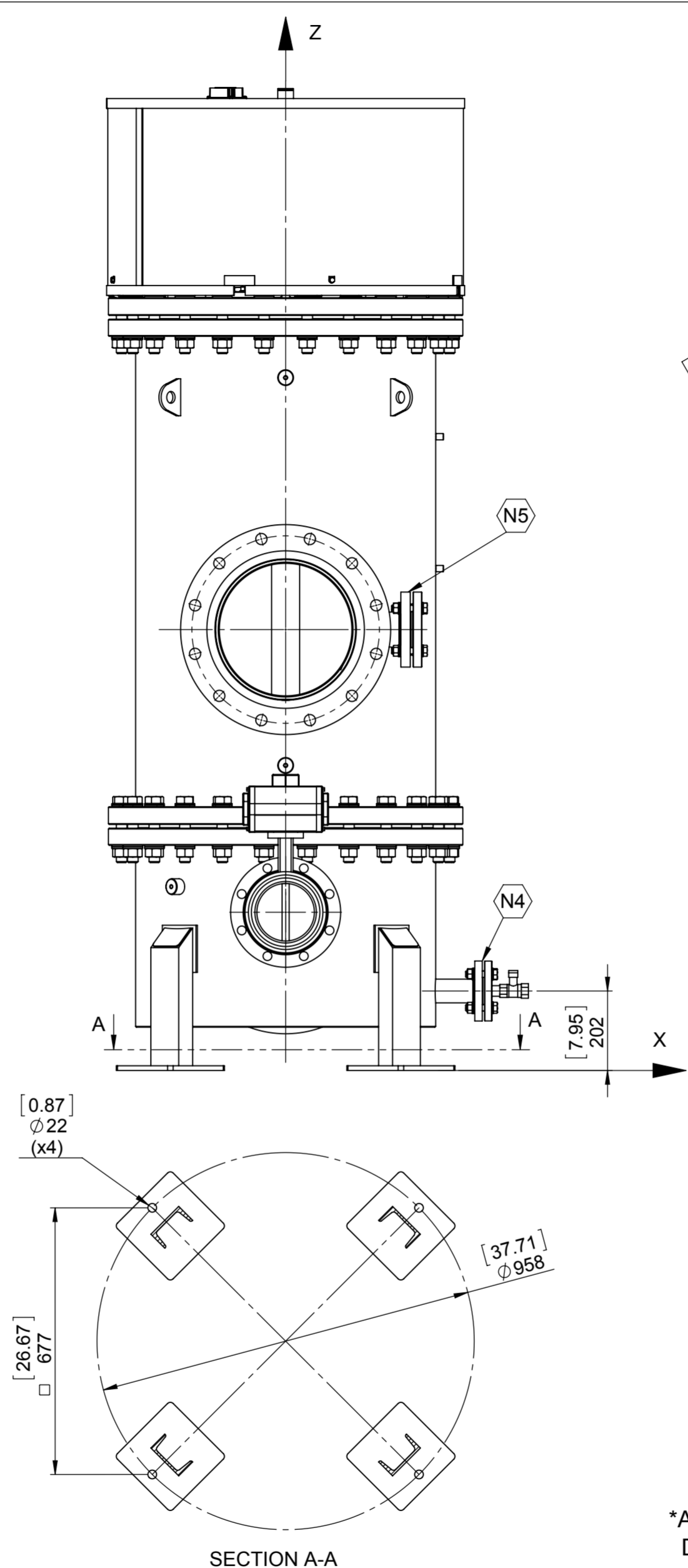
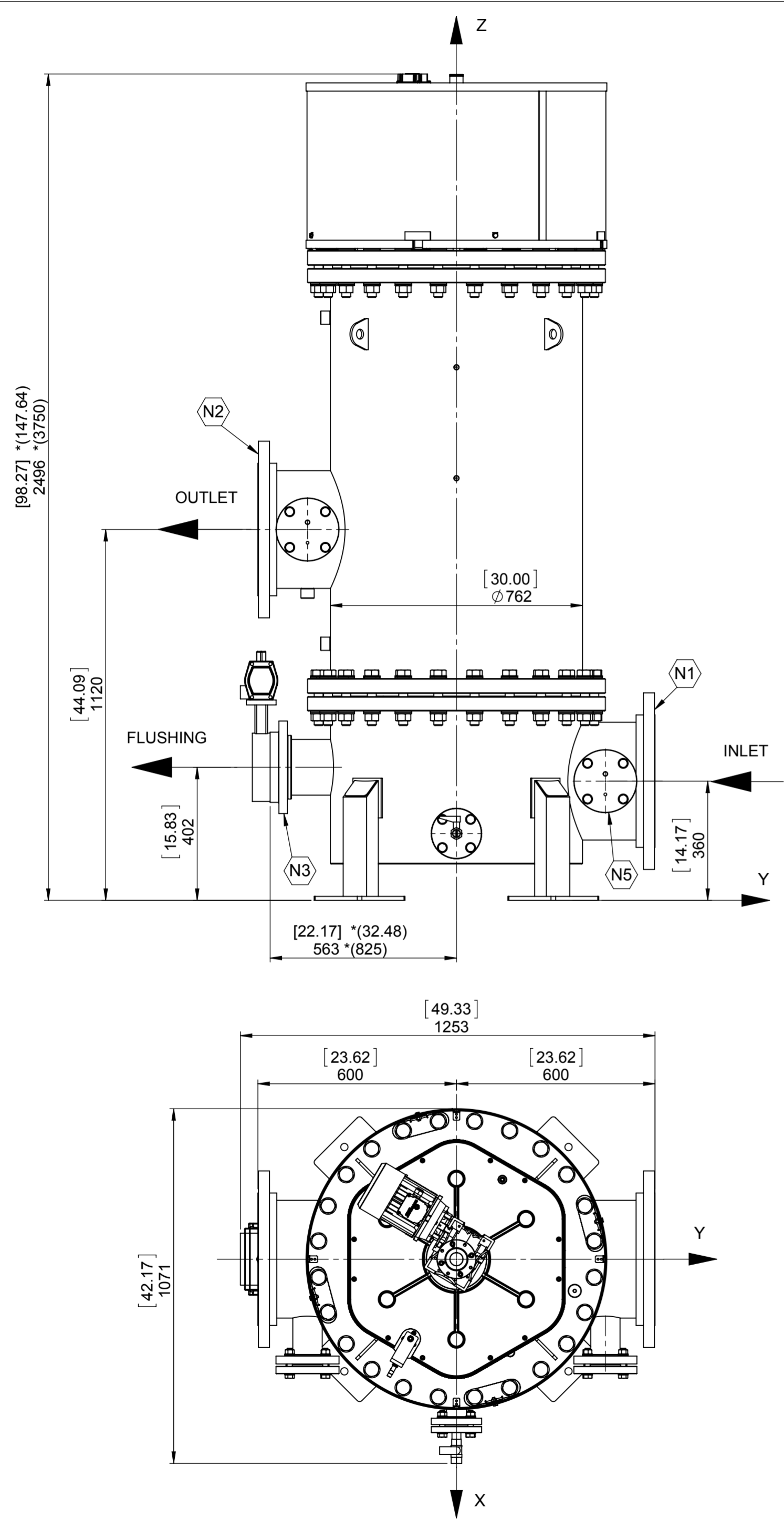

**FOR INFORMATION ONLY**

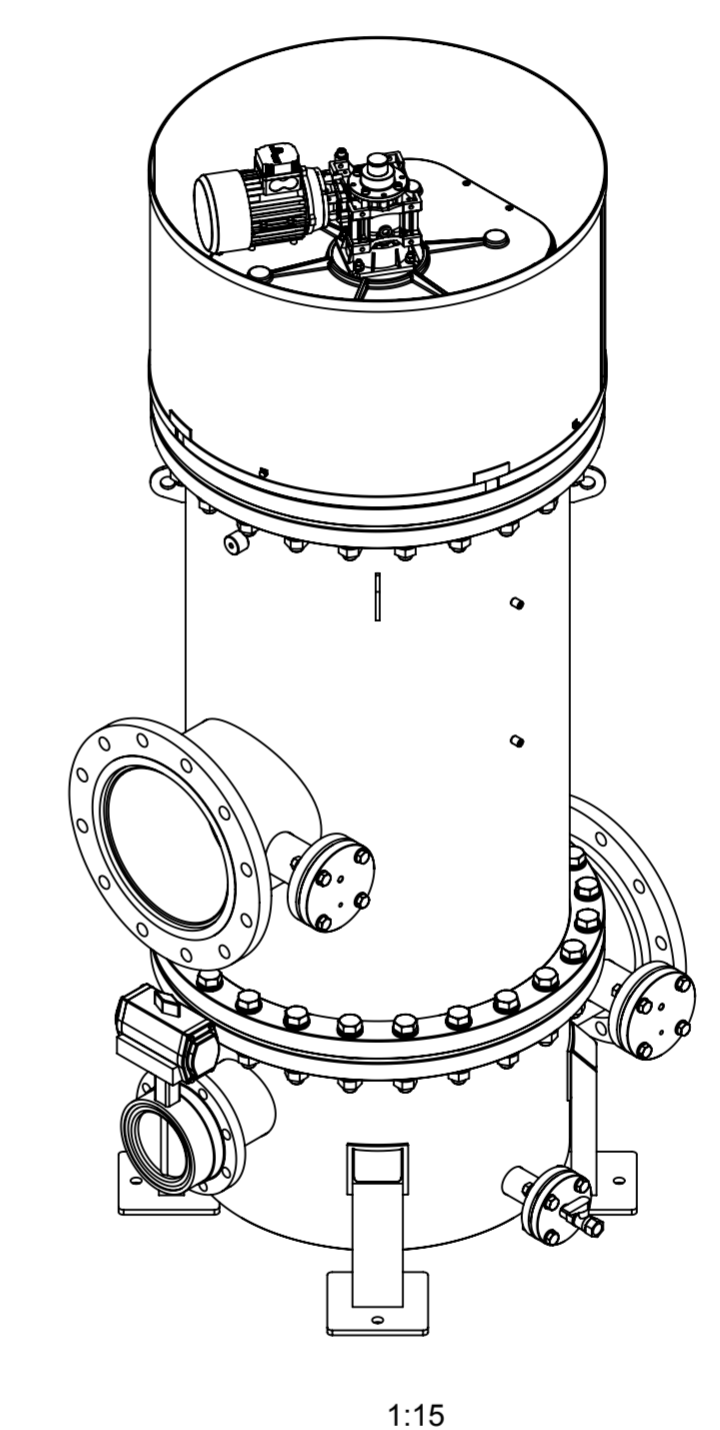

CONSTRUCTION			
Materials For Filter Vessel			
Housing/ Lid: S235JR, SA106B			
Flanges: See Class			
DESIGN CRITERIA			
Design Code	AD-2000		
Design Pressure	10 Bar [145 psi]		
Test Pressure	15 Bar [218 psi]		
Design Temperature	50°C [122° F]		
Volume	785 L [207.4 gallon]		
TOTAL WEIGHT			
	KG	LB	
Empty	1455	3208	
Operating	2240	4939	
Lid (without accessories)	207	457	
CENTER OF GRAVITY mm [Inch]			
	X	Y	Z
Empty	6 [0.24]	-8 [-0.31]	1106 [43.54]
Operating	4 [0.16]	-6 [-0.24]	1091 [42.95]

0	13/10/2015	FIRST ISSUE	O.W.	I.Z.	I.Z.
	Date	Reason for Issue	By	Chk	Apr
REVISION					



PROJECT: 14" OMEGA-II-E 36K Filter AD2000 S  
TITLE: 14" OMEGA-II-E 36K Filter AD2000 S

IMO No.	CLASS I.D.	SCALE (A2)	REV
		1:12	0

Draw. No : QP-0464 SHEET NO.1 OF 1

\*APPROX. LENGTH FOR MAINTENANCE DIMENSIONS ARE IN MM [INCH]

NOZZLES LIST						
CODE	QTY.	DN	CLASS	PIPE	FLANGE TYPE	SERVICE
N1	1	14"	BY DEMAND	VARY	S.O.R.F	INLET
N2	1	14"	BY DEMAND		S.O.R.F	OUTLET
N3	1	6"	BY DEMAND		S.O.R.F	FLUSHING
N4	1	2"	BY DEMAND		S.O.R.F	DRAINAGE
N5	2	3"	#150		S.O.R.F	INSTRUMENTATION



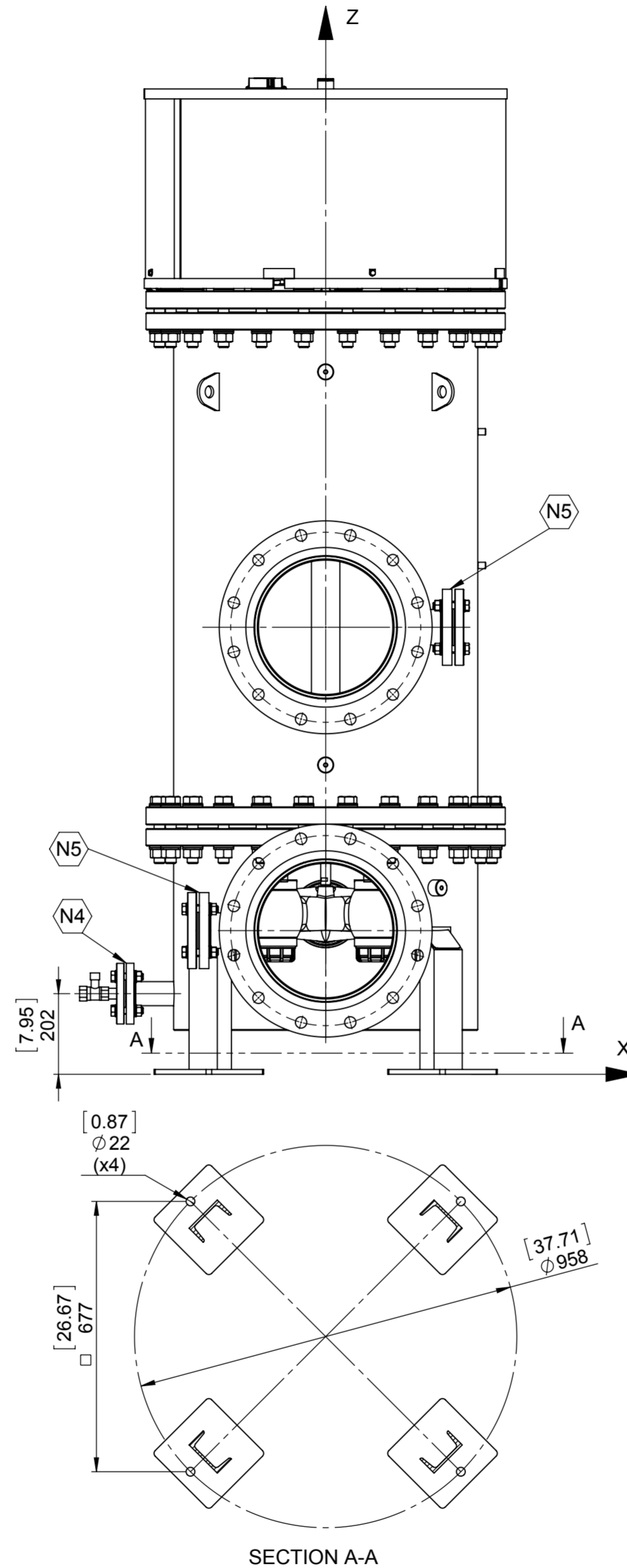
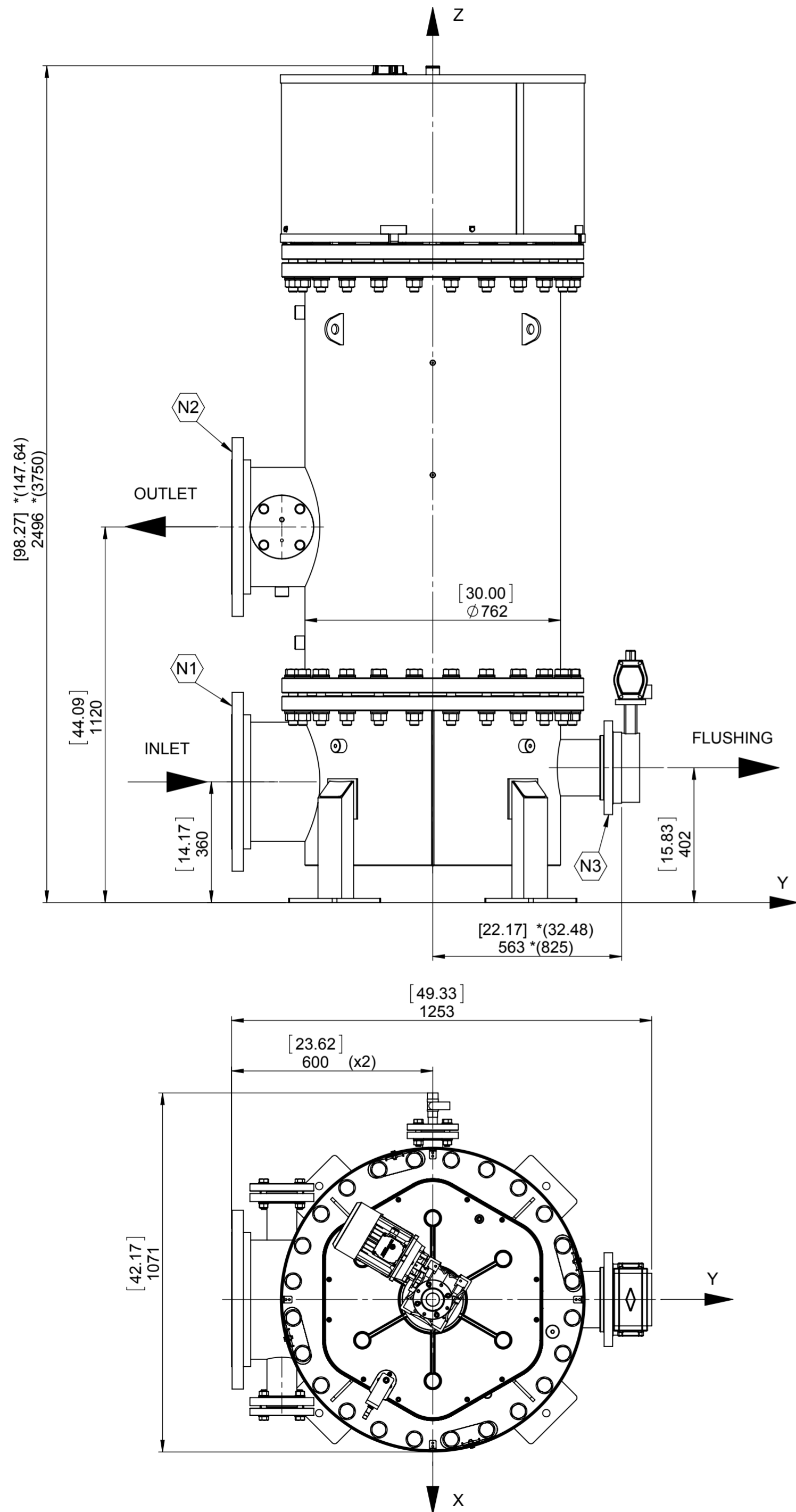

**FOR INFORMATION ONLY**

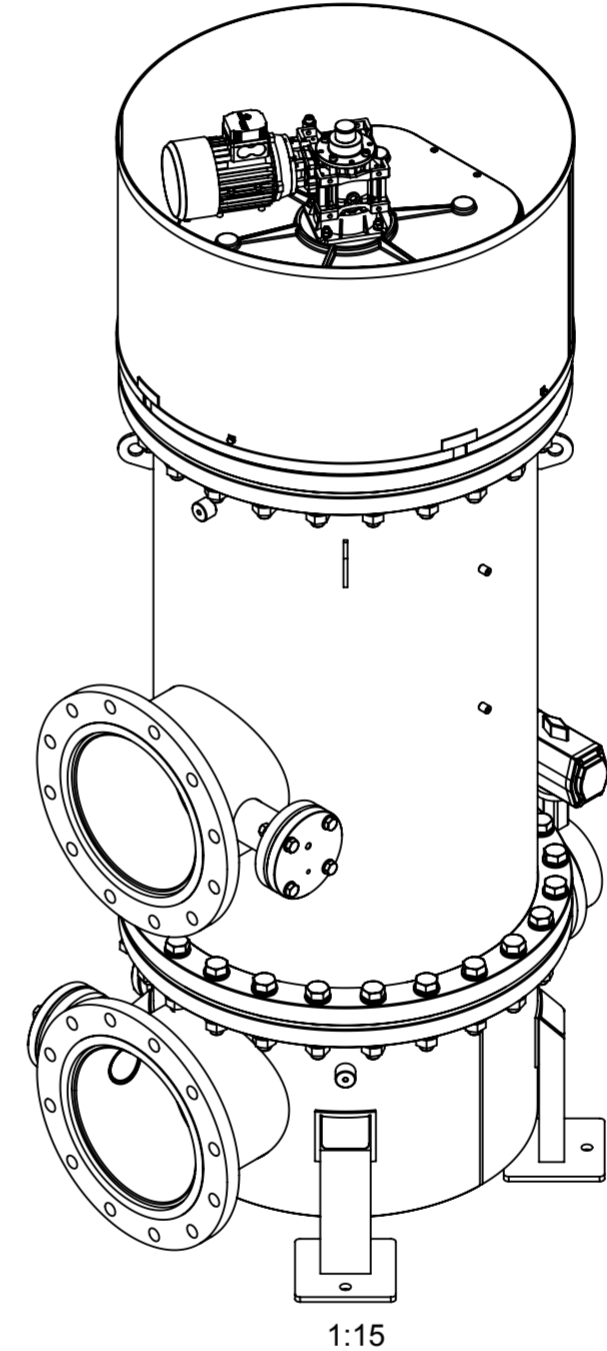

\*APPROX. LENGTH FOR MAINTENANCE  
DIMENSIONS ARE IN MM [INCH]

NOZZLES LIST						
CODE	QTY.	DN	CLASS	PIPE	FLANGE TYPE	SERVICE
N1	1	14"	BY DEMAND	VARY	S.O.R.F	INLET
N2	1	14"	BY DEMAND		S.O.R.F	OUTLET
N3	1	6"	BY DEMAND		S.O.R.F	FLUSHING
N4	1	2"	BY DEMAND		S.O.R.F	DRAINAGE
N5	2	3"	#150		S.O.R.F	INSTRUMENTATION

<b>CONSTRUCTION</b>			
Materials For Filter Vessel			
Housing/ Lid: S235JR, SA106B			
Flanges: See Class			
<b>DESIGN CRITERIA</b>			
Design Code	AD-2000		
Design Pressure	10 Bar [145 psi]		
Test Pressure	15 Bar [218 psi]		
Design Temperature	50°C [122° F]		
Volume	785 L [207.4 gallon]		
<b>TOTAL WEIGHT</b>			
	KG	LB	
Empty	1455	3208	
Operating	2240	4939	
Lid (without accessories)	207	457	
<b>CENTER OF GRAVITY mm [Inch]</b>			
	X	Y	Z
Empty	-3.8 [-0.15]	-41 [-0.31]	1106 [43.54]
Operating	-2.6 [-0.1]	-38.6 [-1.52]	1091 [42.95]

0	13/10/2015	FIRST ISSUE	O.W.	I.Z.	I.Z.
	Date	Reason for Issue	By	Chk	Apr



PROJECT: 14" OMEGA-II-E 36K Filter AD2000 S  
TITLE: 14" OMEGA-II-E 36K Filter AD2000 S

IMO No.	CLASS I.D.	SCALE (A2)	REV
		1:12	0

REV.	DATE	DESCRIPTION	ECO NO.	NAME
8				

# OMEGA 27K Filter

## Typical P&ID and Scope Of Supply Limits

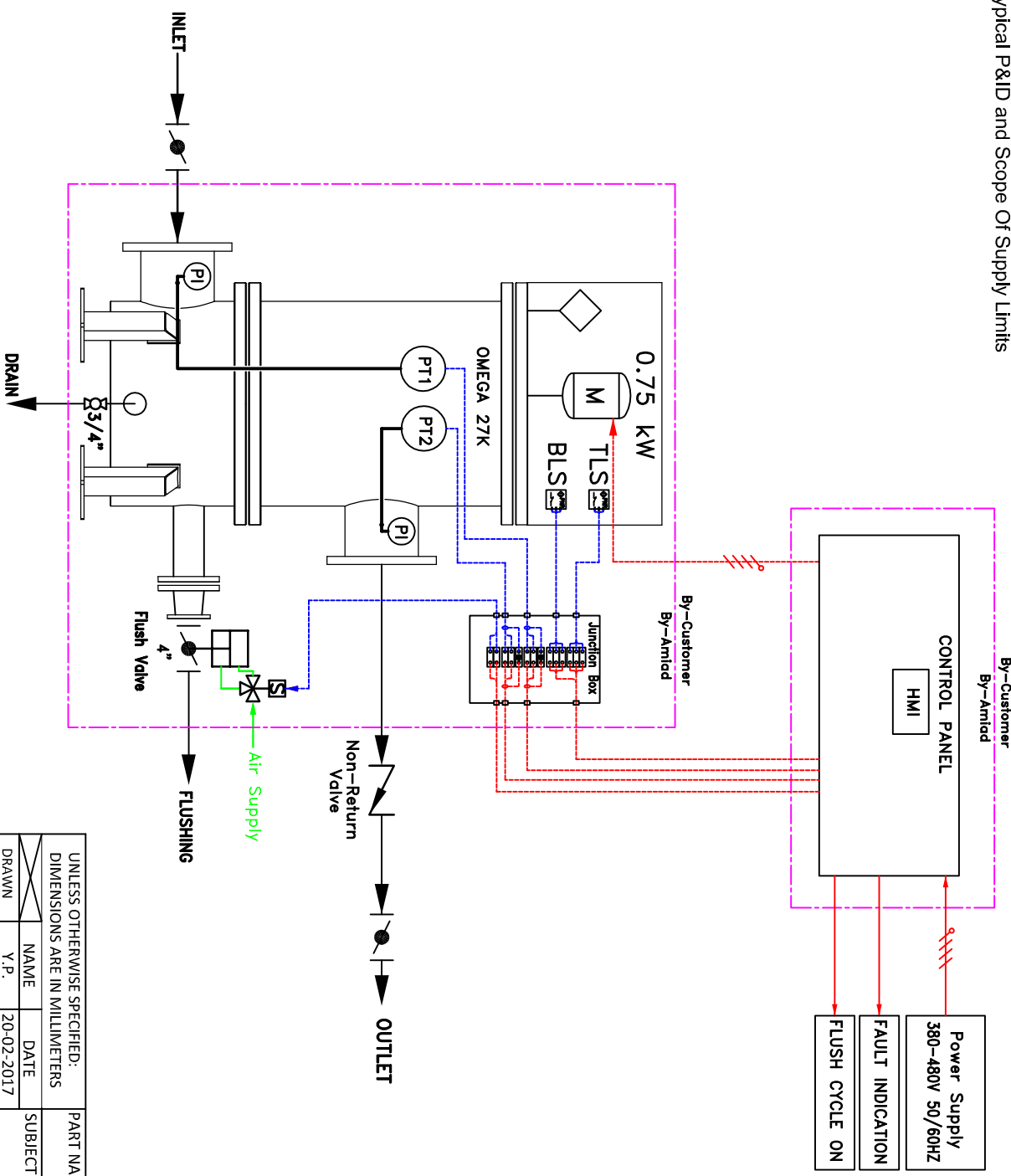

LEGEND	
	Non Return Valve
	Manual Butterfly Valve
	Ball Valve
	Pneumatic Butterfly Valve
	Solenoid Valve
	Pressure Indicator (Gauge)
	Pressure Transmitter
	Wiring by Amlad
	Wiring by Customer

UNLESS OTHERWISE SPECIFIED: DIMENSIONS ARE IN MILLIMETERS		
NAME	DATE	
Y.P.	20-02-2017	
APPROVED		

PART NAME / TITLE: <b>OMEGA 27K</b>		P&ID and Scope Of Supply Limits	
SUBJECT / PROJECT:		MATERIAL:	
WEIGHT:		CAT. NO.:	
DRAWN NO.:		DRW. REV.:	
SCALE: N/A		SIZE: A3	
SHEET 1 OF 1			

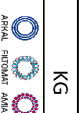

CONFIDENTIAL PROPERTY INFORMATION.  
Amlad Water Systems Ltd.  
Reserves the rights to make changes.  
All copy rights reserved to  
Amlad Water Systems Ltd.

REV.	DATE	DESCRIPTION	ECO NO.	NAME
8				

# OMEGA 36K Filter

## Typical P&ID and Scope Of Supply Limits

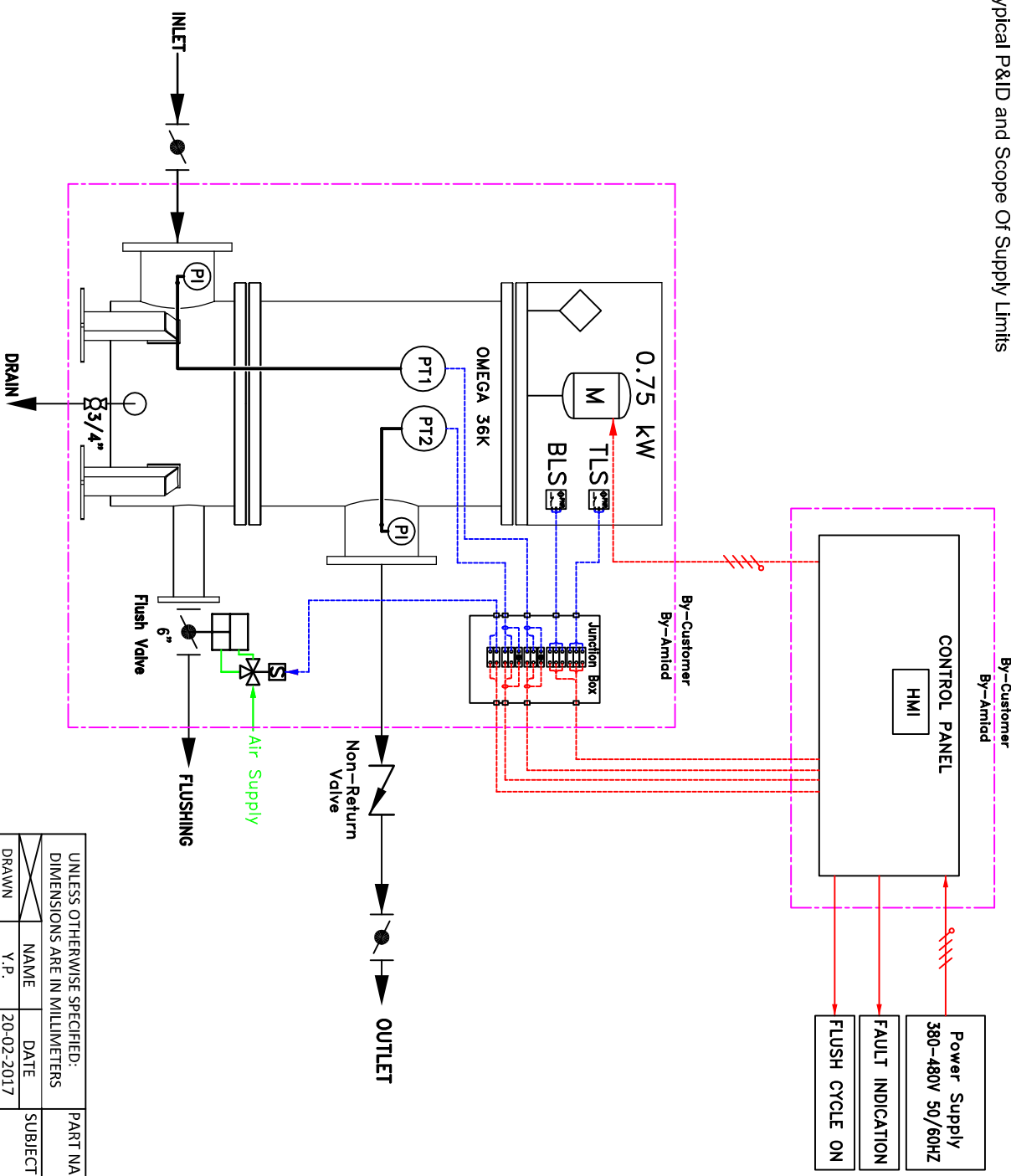

LEGEND	
	Non Return Valve
	Manual Butterfly Valve
	Ball Valve
	Pneumatic Butterfly Valve
	Solenoid Valve
	Pressure Indicator (Gauge)
	Pressure Transmitter
	Wiring by Amiad
	Wiring by Customer

UNLESS OTHERWISE SPECIFIED: DIMENSIONS ARE IN MILLIMETERS			
NAME	DATE		
Y.P.	20-02-2017		
APPROVED			
Confidential property information. Amiad Water Systems Ltd. Reserves the rights to make changes. All copy rights reserved to Amiad Water Systems Ltd.			

PART NAME / TITLE:		OMEGA 36K	
SUBJECT / PROJECT:		P&ID and Scope Of Supply Limits	
MATERIAL:	CAT. NO.:	DRW. NO.:	DRW. REV.:
		M-BW-YP-0001	
WEIGHT:	SCALE:	SIZE:	SHEET:
KG	N/A	A3	1 OF 1

REV.	DATE	DESCRIPTION	ECO NO.	NAME
8				

- KEY:
1. 14" INLET MANIFOLD
  2. 14" INLET BUTTERFLY VALVE
  3. 14" OMEGA-IE 36K FILTER
  4. 14" NON RETURN VALVE
  5. 14" OUTLET BUTTERFLY VALVE
  6. 14" OUTLET MANIFOLD
  7. 6" PNEUMATIC FLUSHING VALVE
  8. 6" FLUSHING MANIFOLD
- h=Recommended Height For Service Platform

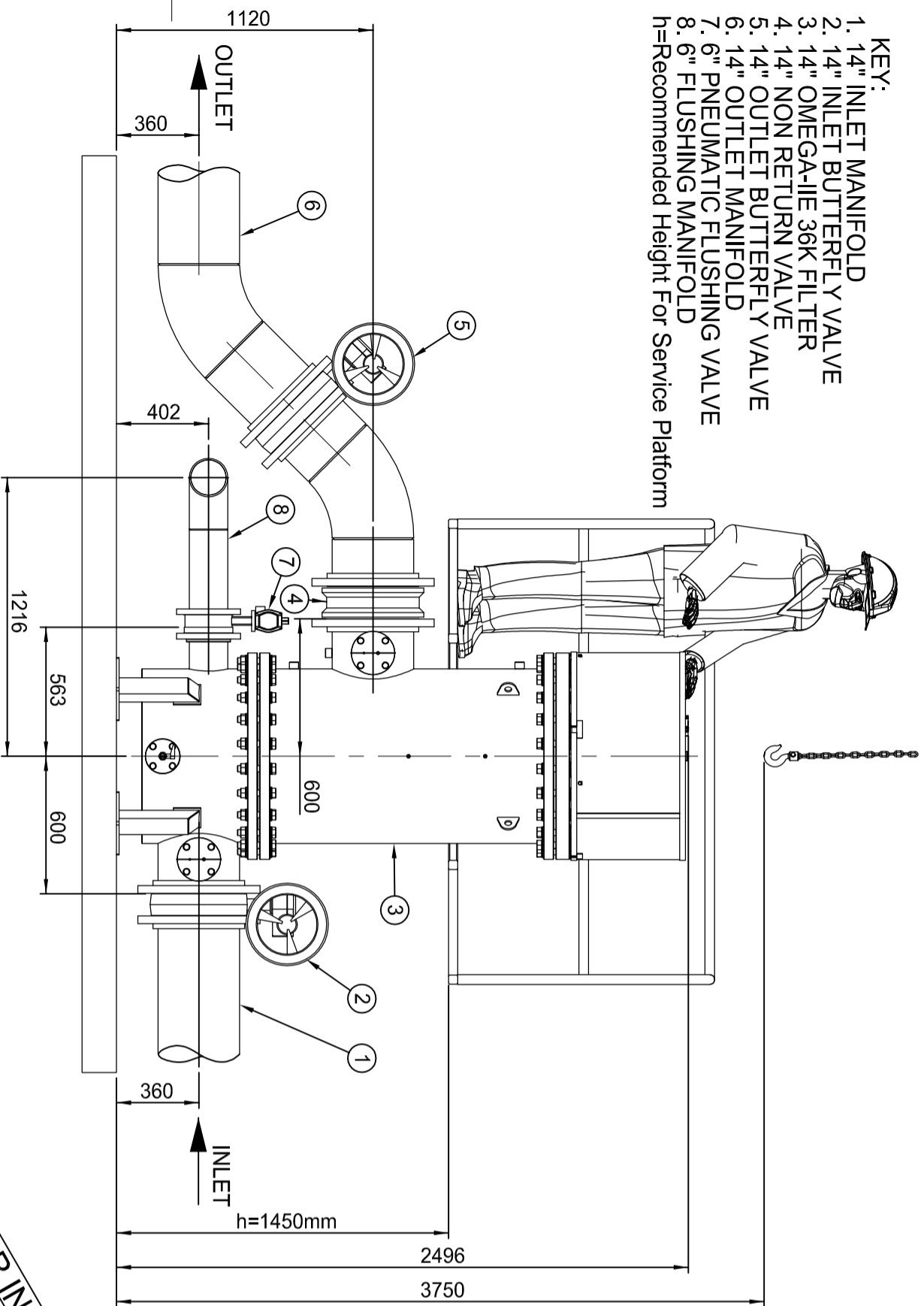

FOR INFORMATION ONLY

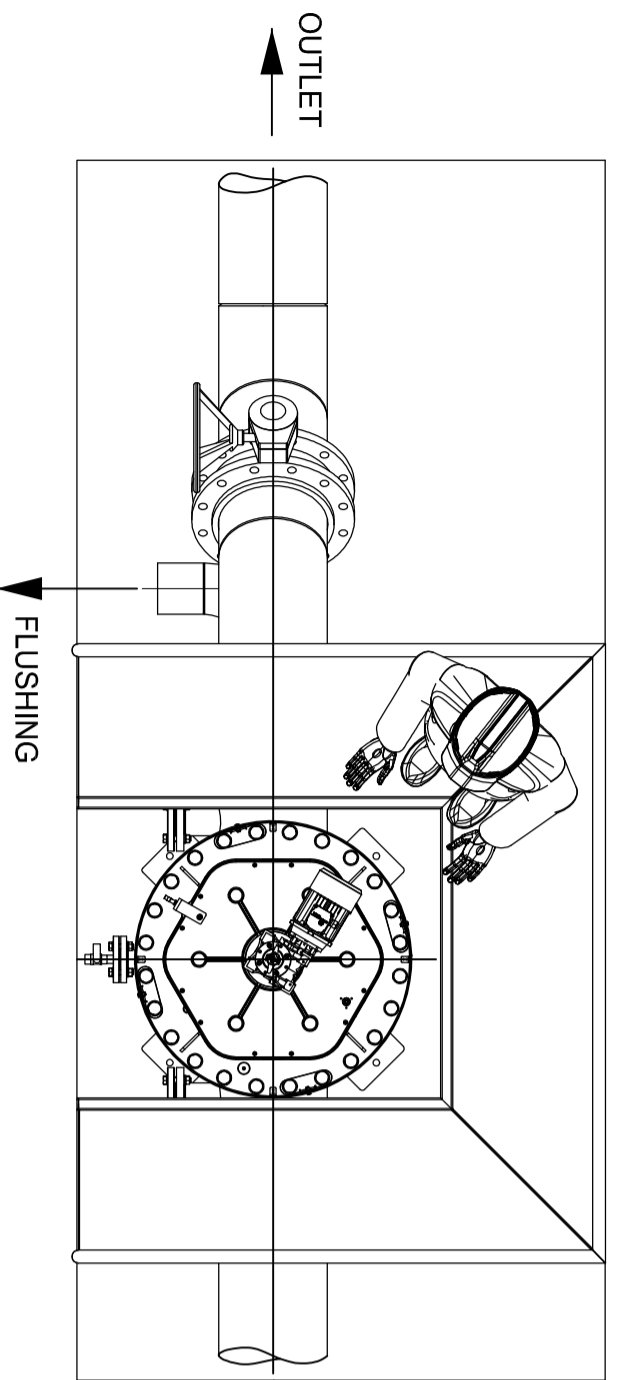
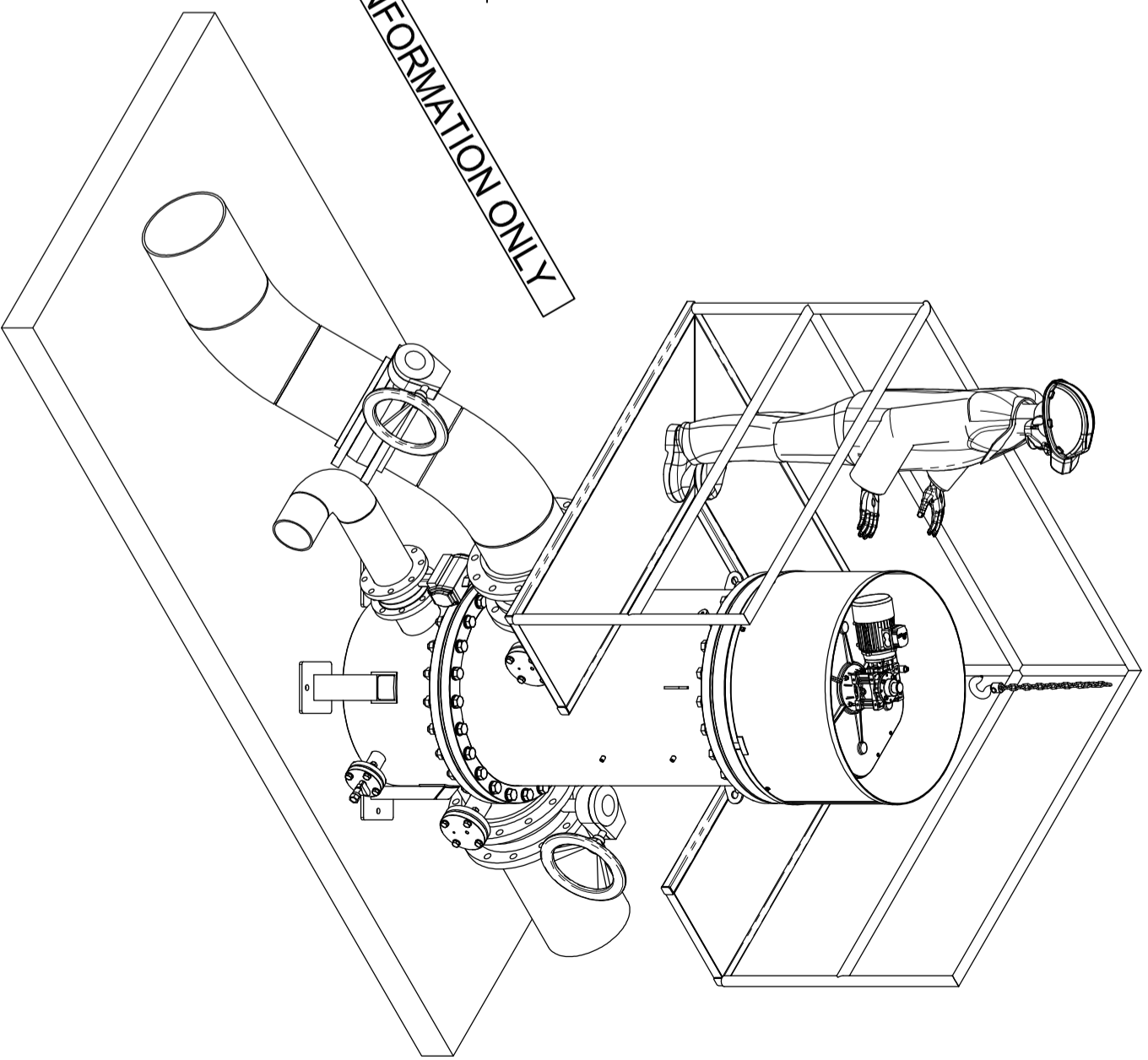

UNLESS OTHERWISE SPECIFIED:  
DIMENSIONS ARE IN MILLIMETERS

NAME	DATE
Yossi B	09/02/2017
Yoram P	09/02/2017

APPROVED

PART NAME/TITLE: 14" OMEGA-36k Filter	DRW. NO.: M-8
SUBJECT/PROJECT: OMEGA-36k SYSTEMS	SCALE: 1:25
MATERIAL: Various	SIZE: A3
WEIGHT:	SHEET 1 OF 1
CONFIDENTIAL PROPERTY INFORMATION. Amiad Water Systems Ltd. Reserves the rights to make changes. All copy rights reserved to Amiad Water Systems Ltd.	DRW. REV.: 0

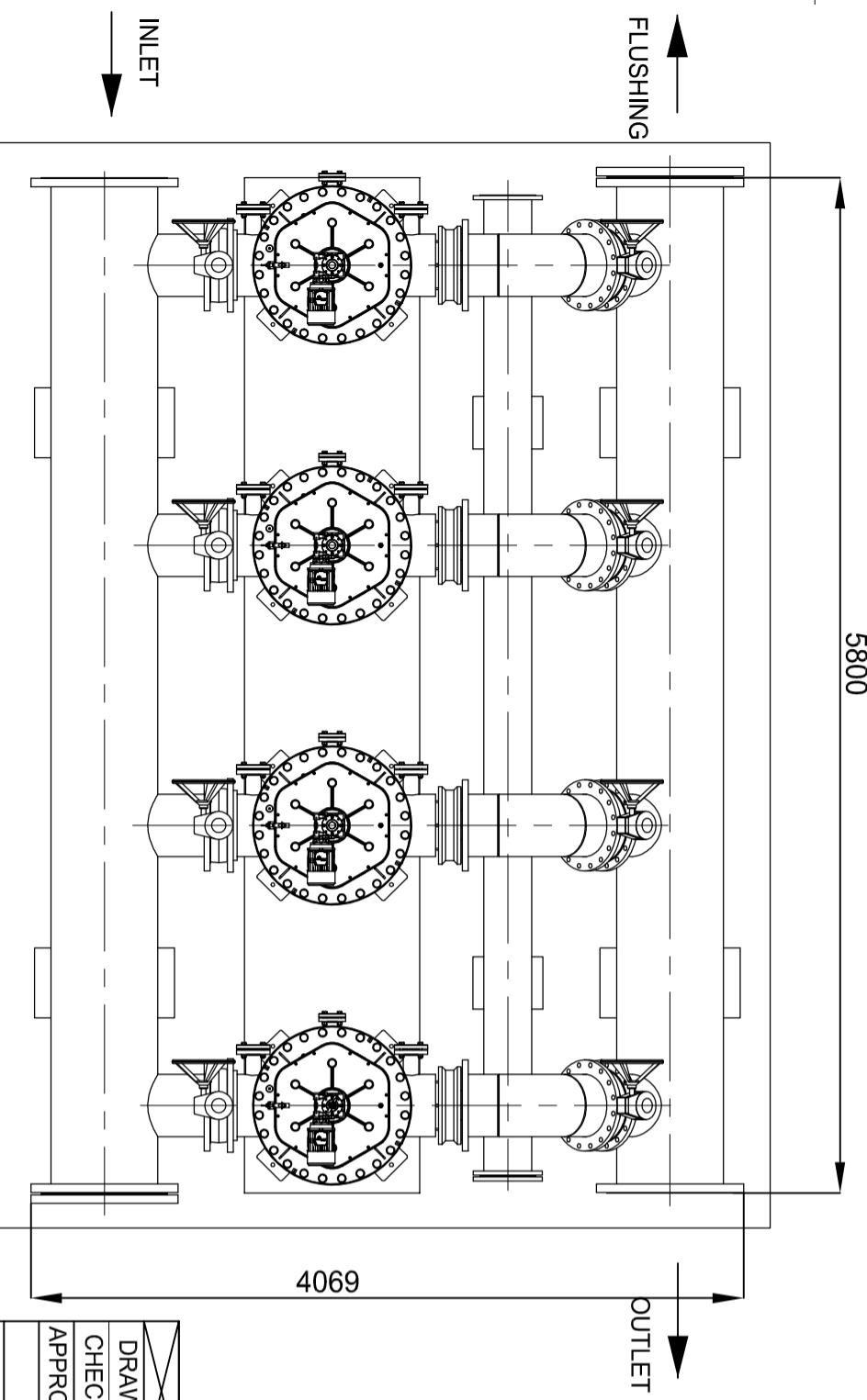
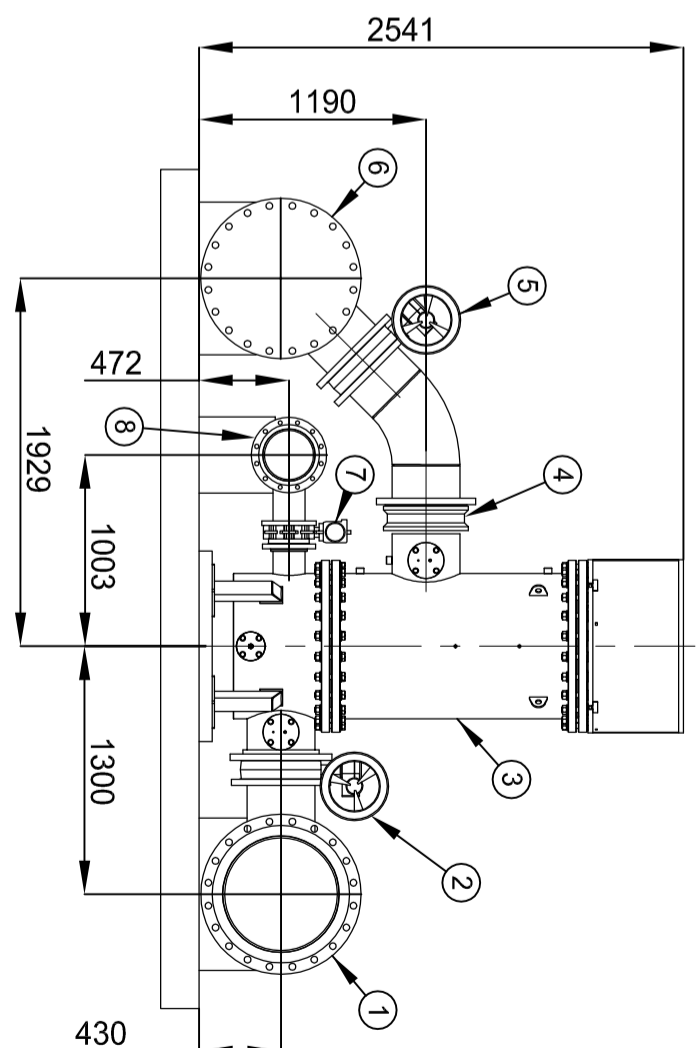
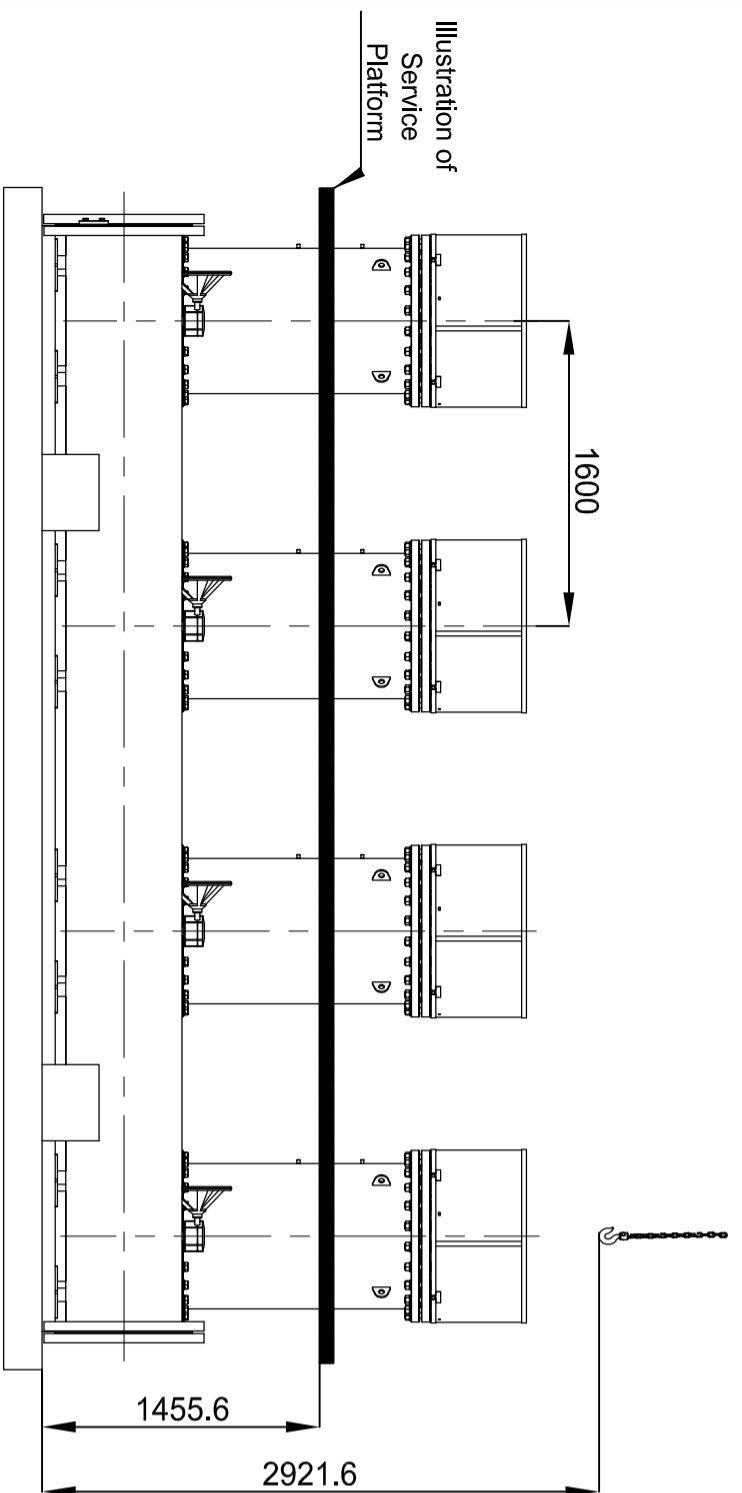

FOR INFORMATION ONLY

- KEY:**
1. 24" INLET MANIFOLD
  2. 14" INLET BUTTERFLY VALVE
  3. 14" OMEGA-36k FILTER
  4. 14" NON RETURN VALVE
  5. 14" OUTLET BUTTERFLY VALVE
  6. 24" OUTLET MANIFOLD
  7. 6" PNEUMATIC FLUSHING VALVE
  8. 10" FLUSHING MANIFOLD
- h=Recommended Height For Service Platform

REV.	DATE	DESCRIPTION	NAME
1			
2			
3			
4			

<input checked="" type="checkbox"/>	NAME	DATE
<input checked="" type="checkbox"/>	DRAWN	Yossi B 12/02/2017
<input checked="" type="checkbox"/>	CHECKED	
<input checked="" type="checkbox"/>	APPROVED	

SUBJECT/PROJECT:  
OMEGA-36k SYSTEMS

PART NAME/TITLE:  
4x14" OMEGA-36k SYSTEMS Filter On 24" Manifold

MATERIAL:

CAT. NO.:

DRW. NO.:

M-9

Rev. 0

Confidential property information.  
Amlad Water Systems Ltd.  
reserves the rights to make changes.  
All copy rights reserved to  
Amlad Water Systems Ltd.



SCALE: 1:40 SIZE: A3 SHEET 2 OF 2

FOR INFORMATION ONLY

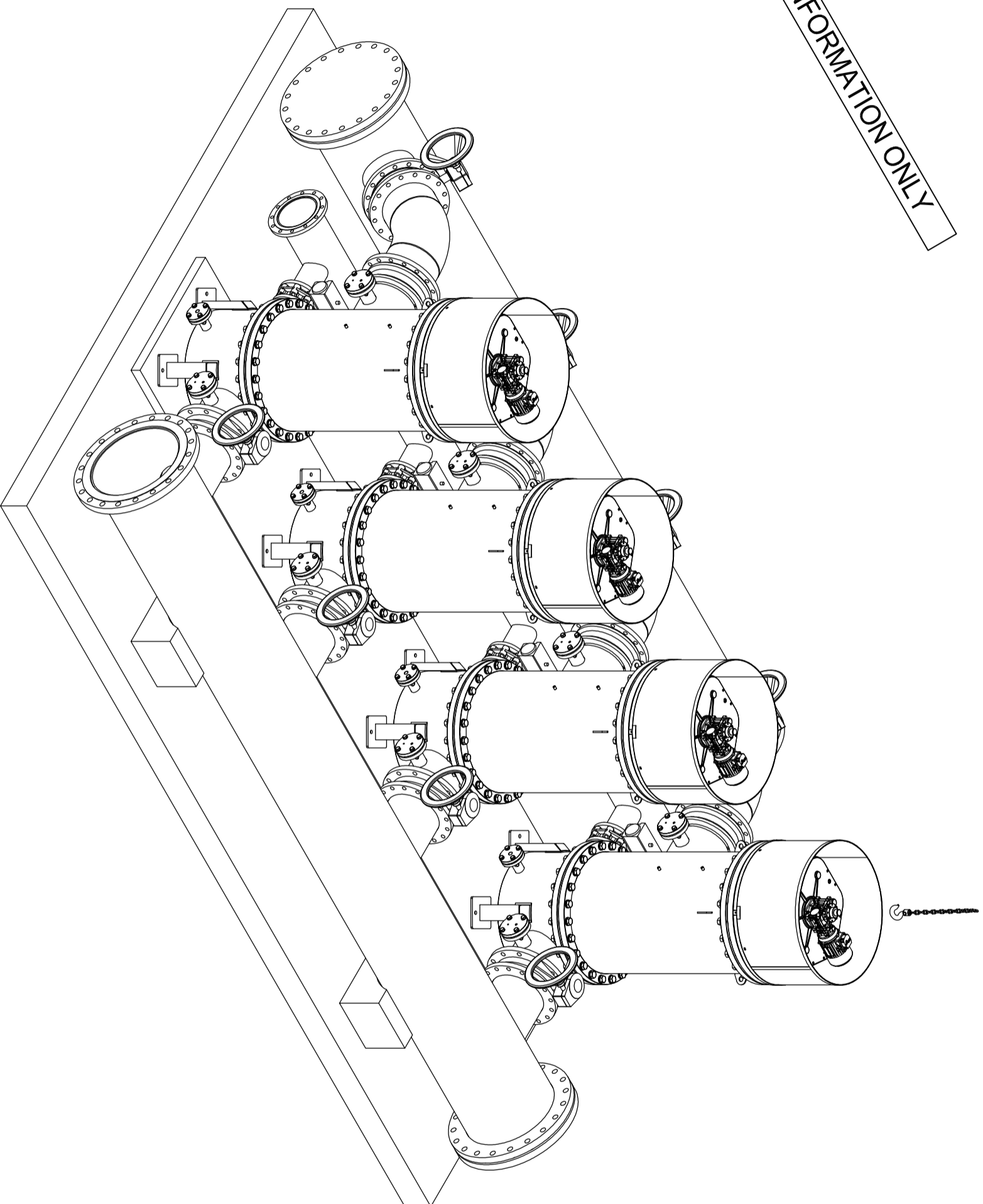

NAME	Yossi B	DATE	12/02/2017	SUBJECT/PROJECT:	OMEGA-36k SYSTEMS	MATERIAL:		
CHECKED				PART NAME/TITLE:	4x14" OMEGA-36k SYSTEMS Filter On 24" Manifold	CAT. NO.:		
APPROVED						DRW. NO.:	M-9	
<p>Confidential property information.          Amlad Water Systems Ltd.          reserves the rights to make changes.          All copy rights reserved to          Amlad Water Systems Ltd.</p>				  		SCALE: 1:30	SIZE: A3	SHEET 1 OF 2
							Rev.	0

## **6. Description of Filter Operation**

## a. Filter Operation

Amiad's Omega Series is composed of automatic filters, with multiple screens operated by a common electric driven screen cleaning mechanism. The "Omega" filter flow rate ranges up to 5,000 m<sup>3</sup>/h (22,000 gpm) and on the 10-500 micron filtration degree range. Inlet/Outlet flanged connections are available in the range of 200-800 mm (8"-32").

The OMEGA is a sophisticated yet easy-to-operate automatic filter, with a varying range of filtration screen elements, from 3 to 18, based on the model. There are two available filtration element sizes – 0.45 m<sup>2</sup> and 6.0 m<sup>2</sup>. Each filtration element is equipped with a self-cleaning assembly. Every 3 or 6 assemblies are driven by a common electric motor and unique transmission gear.

### Filtering Process

Raw water enters from the filter inlet and passes through the multi-screens. Filtered water flows through the filter outlet. The gradual dirt buildup on the inner screens surface causes an increase of the pressure differential across the filter.

The self-cleaning process begins when the pressure differential reached a pre-set value.

### Self-Cleaning Process

The self-cleaning process starts when the pressure differential across the screens reaches a pre-set value or a predetermined lapse of time has passed.

The exhaust valve open creating high velocity suction force at the scanners' nozzles' edges which "vacuums" the filter cake from the screen's surface.

The multiple SLN (Spring Loaded Nozzles) suction scanners are simultaneously scan the screens in a spiral path by a 2-way (fwd/rev) common motorized drive transmission.

During the self-cleaning process, which takes approximately 25 seconds, filtered water continues to flow through the filter.

### Cleaning Cycle Stages

1. Exhaust valve opens to atmosphere.
2. 3 seconds delay.
3. Motor starts rotating the suction scanner shafts upward until the transmission reach the upper proximity sensor.
4. Motor stops and the exhaust valve closes.
5. The filter is ready for the next flushing cycle.  
In the next flush cycle the motor will rotate the transmission gear downward (CW) until reaching the lower proximity sensor.

### Operation Modes

The Omega filter may be found in any of the following modes:

1. Filtering mode: This is the normal function condition. DP value is below set point. Flushing is not active and the control system is ready to initiate a flushing cycle.
2. Flushing mode: A mode in which the flushing process is in progress. The motor and the exhaust valve are operating according to the program.
3. Continuous flushing mode: Flushing process continue regardless DP. Flushing valve remains open. Suction pump (if exists) running and suction scanners moving up and down with 1 second delay between strokes.
4. Malfunction mode: During malfunction mode the self-cleaning operation is stopped, filtration may continue but DP is climbing up and flow will be reduced. A fault light on the control board should turn on and a relevant message should be displayed on the HMI.

The filter will enter a malfunction mode in the following cases:

- High DP for duration longer than a pre-set time. This means that the self-cleaning process is not successful.
- Motor protector tripped due to mechanical resistance or electrical failure.
- Limit Switch (Proximity Switch) failure.



## Initiation of Self-Cleaning

Flush Cycle may start as a result of any of the following:

1. Pressure Differential
2. Time Interval
3. Manual Start from local control panel
4. Manual Start from remote control system

## Pressure Differential Operation

A flush cycle starts if the PD Value (calculated or measured) is  $\geq$  Pre-Set value for at least 3 seconds. The signal for flushing will remain ON as long as the PD value  $\geq$  Pre-Set value + 5 seconds. The Pre-Set PD value shall be defined through the HMI.

## Time Interval

Cleaning according to a pre-set time interval is recommended as an option.

The Time Interval shall be determined through the HMI.

The flush cycle starts when the time counter is  $\geq$  to the pre-set time.

The time counter is re-set back to zero when any flush cycle begins (regardless of whether it is a result of PD, time or manual start).

## Continuous Flushing

In continuous flushing mode the valve remains open all the time.

The filter's motor stops for one second at the limit switch before turning rotation direction.

Continuous flushing mode is used in heavy contamination loads conditions to prevent increasing of DP.

Continuous mode should be used for limited time only in order to save water, energy and avoid too much mechanical wear.

## Manual / Test Operation

Push-Button (Hardware or on the HMI) to start Flush cycle regardless DP or time interval.

## OMEGA Models

Amiad's Omega Series product line consists of the following models.

Each model includes one motor and one exhaust valve, as follows:

- Omega 4.5K, with 1 filtration element, for up to 180 m<sup>3</sup>/h (800 gpm)
- Omega 6K, with 1 filtration element, for up to 240 m<sup>3</sup>/h (1,100 gpm)
- Omega 13.5K with 3 filtration elements, for up to 550 m<sup>3</sup>/h (2,400 gpm)
- Omega 18K with 3 filtration elements, for up to 750 m<sup>3</sup>/h (3,300 gpm)
- Omega 27K with 6 filtration elements, for up to 1,100 m<sup>3</sup>/h (4,800 gpm)
- Omega 36K with 6 filtration elements, for up to 1,500 m<sup>3</sup>/h (6,600 gpm)
- Omega 54K with 9 filtration elements, for up to 2,250 m<sup>3</sup>/h (9,900 gpm)

## b. Cross Section Drawing

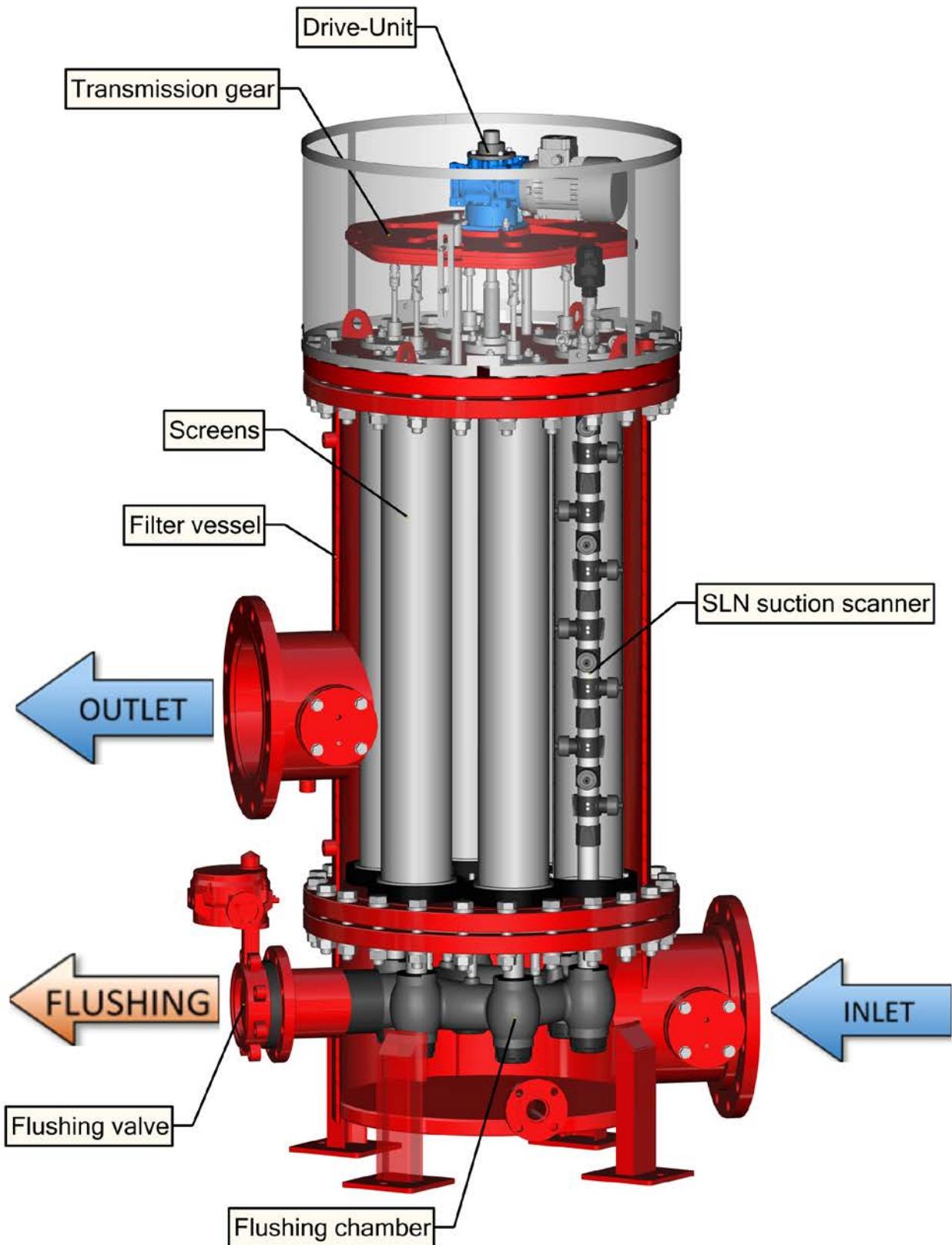

## **7. Control Philosophy**

## a. Control Concept – Single Filter

This section describes the basic principles of the Omega Filter's control system. This information is applicable for both; control panels provided by Amiad or for panels provided by others.

### Electrical Components and Instrumentations

- 0.55, 0.75, or 1.2KW, 3 Phase motor (Two rotation directions)
- 2 X NC Proximity Switches or mechanical limit switches
- 3-way NC Solenoid - Operating Pneumatic Actuated Butterfly Valve with or without limit switches. (Motorized valve is optional)
- One of the below instrumentation options:
  - a. PDT 4-20 mA pressure differential transmitter
  - b. 2 x PT 4-20 mA pressure transmitters (inlet / outlet)
  - c. PDS pressure differential switch

### PLC I/O Basic List

<b>Digital Inputs:</b>		<b>Function</b>	<b>Comments</b>
01	Test	Local start of flush cycle	Push-Button or command from HMI
02	START	Remote start flush cycle	Signal from remote supervision system
03	RESET	Stop flush cycle and clear faults / alarms	Push-Button (Remote signal is not recommended )
04	PAUSE	Flushing prevention	Signal from remote supervision system
05	PDS	N.O. Pressure Differential Switch	Option c
06	TLS 1	Top Limit Switch (N.C.)	Mechanical or Proximity Switch
07	BLS 1	Bottom Limit Switch (N.C)	Mechanical or Proximity Switch
08	O.L. 1	Overload Motor Protector	Fault or run indication from motor starter
10	ZSO	Valve Position Limit Switch - OPEN	Option - Mechanical or Proximity Switch
11	ZSC	Valve Position Limit Switch - CLOSE	Option - Mechanical or Proximity Switch
<b>Digital Outputs:</b>			
01	CON	Cycle On (Flushing in process)	Lamp and/or free potential signal
02	SOK	No Fault (System OK)	Lamp and/or free potential signal
03	F	Fault Lamp	Blinking when Alarm; On in Fault Mode
04	XV1	Solenoid Valve	Motorized actuator as an option
05	CU1	Motor Starter Up (CCW)	Contact
06	CD1	Motor Starter Down (CW)	Contact
<b>Analog Inputs:</b>			
01	DPT	Differential Pressure 4-20 mA	Option a
02	PT1	Inlet Pressure 4-20 mA	Option b
03	PT2	Outlet Pressure 4-20 mA	Option b
<b>Analog Outputs:</b>			
01		DP Value (Optional)	Analog signal to remote supervision system

## Functional Description:

### 1. **Request for Flushing:**

Flush Cycle will start as a result of anyone of the following triggers:

- **Pressure Differential:**

A signal will be considered as ON (1) if lasts for at least 3 seconds.

A signal will be considered as OFF (0) if it is off for at least 5 seconds.

There are 3 optional measuring methods of the DP:

- a. PDT (Pressure Differential Transmitter) that measures the differential pressure across the filter and compares it with a pre-set value.
- b. 2 X PT (Pressure Transmitter) the DP value is calculated (PT1- PT2) and compared to a pre-set value.
- c. PDS (Pressure differential Switch) A normally open contact in input 05.

- **Remote Start:**

Free Potential Signal in input No. 02 received from Supervision system or other control system.

- **Time Interval:**

Flush Cycle starts if the accumulated time from last flush cycle reaches the Interval Set-Point.

The Time counter re-sets back to zero when the flush cycle starts, regardless if it is caused by DP or by time.

- **Continuous Flushing Mode:**

Flush Valve is open and the motor is running up and down between the limit switches.

There is one second delay before each starting command of the motor.

### 2. **Faults & Alarms:**

There are two types of potential faults – Clogging fault and mechanical fault.

A clogging fault may be caused due to changes in the hydraulic/TSS conditions or as a result of a mechanical problem. In both cases, Flush Cycle stops and Fault or Alarm should be activated.

- **Mechanical Faults:**

1. Motor Time Out:

Motor is ON and there is no signal from any limit switch after more than “X” seconds (note 1).  
Fault released by RESET.

2. Limit Switch Fault:

Both limit switches are OFF (engaged).  
Fault released by RESET.

3. Motor O.L.:

Over Load tripped or no RUN feedback from motor’s starter.  
Released at the O.L. motor protector or by RESET (depends on protection type).

4. Direction Fault:

Motor is running downward (CW) and a signal is received from Top Limit switch  
Reset of this fault should be possible only when no Limit switch is engaged (both ON).  
Changing rotation direction of the motor is required in order to fix the problem.

In Mechanical Fault Mode, the fault lamp is blinking and a relevant message is displayed on the HMI.

- **Clogging Fault (PD Time Fault):**

DP Value > Set-point or Input 05 is ON for more than 5 minutes (pre-determined).

**Optional logic:** Two set-points to be defined; HDP (High DP) and HHDP (Very High DP). The controller will activate an ALARM if DP reaches the HDP set-Point but flushing will be stopped only if and when DP reaches the HHDP level.

In Clogging Fault Mode or when in Mechanical Fault + Request for Flushing; the flush cycle stops or does not start, the SOK (No Fault) output turns Off and a relevant message is displayed on the HMI.

- **Optional Faults and Alarms:**

- a. Alarm when Analog sensor is out of range.
- b. Warning when Inlet Pressure too low – applicable when PT1 exists.
- c. Flush Valve Fails to open or to close – applicable when Valve Actuator is equipped with limit switches.

*Note 1: Proper determining of “X” is critical in order to prevent mechanical damage in case of limit switch failure.*

*“X” value should be the actual time it takes for the transmission gear to move from bottom to top or top to bottom limit switch + 1 second. The idea is that in case of motor over travelling, the motor will stop by this timer and not by the O.L. protector.*

*“X” value need to be verified for each individual motor and updated after each time of limit switch adjustment.*

### 3. **Flush Cycle Stages:**

1. Request for flushing
2. Output 01 (Cycle On) turns On
3. One second delay (programmable via HMI)
4. Output 04 turns ON – Flush valve XV1 Open.
5. 3 seconds delay (programmable via HMI)
6. Output 05 turns ON – CU1 activating the motor CCW until the signal from TLS (Top Limit Switch) turns OFF.
7. Output 05 turns Off
8. Output 04 turns Off – Flush valve XV1 Closes

**Please note:**

In the next flush cycle, step 6 will be:

Output 06 turns ON – CD1 activating the motor CW until the signal from BLS (Bottom Limit Switch) turns OFF.

### 4. **Reset:**

Pressing on the Reset Push-button causes:

- a) Stop the flush cycle – Flushing valve closes and the suction scanner moves downward to the bottom limit switch position.
- b) Clear Fault mode.

### 5. **Pause:**

Signal in input 04 will stop the flush cycle (same as Reset).

As long as this input is ON, the system will not enter a flush cycle.

### 6. **Continuous Flushing mode:**

In continuous flushing mode the flush valve remains open.

The filter’s motor stops for one second at each limit switch before turning rotation direction.

Continuous flushing mode is used in heavy TSS loads conditions in order to maintain stable flow at low DP and to avoid high frequency of valve operation.

It is recommended to use the continuous mode for limited duration in order to prevent high wear of the filter internals.

- a. Manual operation of Continuous mode:

Start / Stop Latch Push-Button (Hardware or HMI) to start and stop continuous flushing mode.

Flushing will continue until STOP command or until end of pre-determined duration value set in the HMI (60 – 180 minutes recommended).

- b. Automatic operation of Continuous mode:  
 Filter will switch to continuous flushing if there were 3 consecutive flush cycles with interval shorter than 5 minutes.  
 The filter will stay in continuous flushing for 20 min. or until RESET. Afterwards will turn back to normal operation.  
 Filter will switch to Clogging Fault (PD Time Fault) if a DP signal for duration of 5 min is received while in continuous mode.

*Note: All timers and counters should be programmable per case.*

## HMI Considerations:

### 1. The following information should be displayed on the HMI:

- a. Current Inlet Pressure (PT1) - if applicable
- b. Current DP across the Filter
- c. Current Status: Filtering; Flushing; Continuous Flushing; Fault
- d. Time from Last Flush and time to the next flush (by time)
- e. Cause of last flushing – DP / Time / Test / Remote
- f. Detail of Fault (Limit Switch; Motor Time out....)
- g. Flush Counter

### 2. Parameters setting

The following parameters values should be programmable via the HMI:

- Operating Method: Continuous / Time & DP / DP only
- Rest Flushing counter

Parameter	Units	Range	Default	Comments
a. DP Set point:	Bar(d) / psi (d)	0.1 – 0.7 / 1.5 - 10	0.5 / 7.0	
b. Minimum Inlet pressure:	Bar(g) / psi (g)	1.0 – 10.0 / 15 - 150	2.0 / 30	
c. Interval for flushing by time:	Minutes	1 – 1440	480	0 = Never
d. Time in HDP before Fault:	Minutes	1 – 60	5	
e. Delay before open XV1:	Seconds	0 – 12	1	
f. Delay before Start Motor:	Seconds	0 – 10	3	
g. Time in Continuous - Manual	Minutes	0 - 240	60	
h. Time in Continuous – Auto.	Minutes	0 - 240	20	
i. No. of consecutive cycles	Cycles	1 - 10	3	
j. Interval for consecutive cycles	Minutes	0 - 10	5	

## b. Control Concept – Multiple System

This part is describing the basic principles of the Omega Filter's control system. This information is applicable for both; control panels provided by Amiad or panels provided by others.

Multiple filtration system is an installation of a few filter units on a common manifold system.

The flow is divided between the units by the natural hydraulic resistance of the filter units and the piping system.

The system should be hydraulically designed to provide optimal balance and equal flow through the filtration units.

Since the TSS load distribution is never identical to the flow distribution, even if the design is perfect, some filter units will be clogged before others. However, the DP across these filters will remain equal in all units, only the flow distribution will be changed. Therefore, the DP measuring should always be done between the main inlet manifold and the main outlet manifold.

Flushing of the system is done in sequence - one unit after the other. Every flush cycle must include all the available filters in the system.

In large multiple systems, simultaneous flushing of two or more units at a time can give significant advantage, especially in peak loads situations.

The following description focuses on the system level of the control while the control details of the individual filter can be found in the Standalone Omega filter description.

### Electrical Components On Each Filter Unit

- 0.55, 0.75, or 1.2KW, 3 Phase motor (Two rotation directions)
- 2 X NC Proximity Switches or mechanical limit switches
- 3 way NC Solenoid (Operating Pneumatic Actuated Butterfly exhaust Valve).

### Common Instrumentations for The Entire System

- One of the below instrumentations options:
  - a. PDT 4-20 mA pressure differential transmitter
  - b. 2 x PT 4-20 mA pressure transmitters (inlet / outlet)
  - c. PDS pressure differential switch

### Functional Description

#### 1. **Request for Flushing:**

Flush Cycle will start as a result of any one of the following triggers.

- **Pressure Differential:**  
Same as for a single filter unit, just measuring done across the entire filtration battery.
- **Remote Start:**  
Free Potential Signal from Supervision system start flush cycle of the entire system.
- **Local Start:**  
"Group Test" Pushbutton on local control panel – start cycle of the entire system.  
"Test Filter # 1" Pushbutton on local control panel – start cycle for each filter unit (for maintenance and testing).
- **Time Interval:**  
Flush Cycle starts if the accumulated time from last flush cycle reaches the Interval Set-Point.  
The Time counter re-sets back to zero when the flush cycle starts, regardless if it is caused by DP or by time.
- **Continuous Flushing Mode:**  
Continuous Flushing in system level means that the system is flushing in sequence and at least one filter unit is in flushing mode at all times, regardless of the DP across the system. The number of filters flushing simultaneously depends on the size of the system and the hydraulic conditions.



## **2. Number of filters flushing simultaneously:**

Flushing of two or more filters simultaneously is shortening the duration of the flushing cycle and recovers the DP across the system faster. It is essential in big systems and in heavy load conditions.

It is recommended to have it as an option in every multiple system. However, the drain piping system must be designed to handle the extra flow.

It is possible to add features to the PLC logic so that if a new DP signal is received before the end of the current flush cycle, the PLC automatically adds one unit to flush simultaneously.

## **3. Faults & Alarms:**

In this document Fault is defined as a situation in which the Filter/ Filtration System is out of order, cannot clean itself and must be shut down.

Alarm is defined as situation in which some elements in the filter or some filters in the system are in fault mode but the system is still functioning and filtration may continue.

The same logic that applies in a standalone unit is relevant with multiple systems.

Filter unit that is in a mechanical fault mode and cannot flush, is skipped in the sequence and will be considered as an Alarm in the multiple system level.

### **• Potential System faults:**

1. DP Value > Set-point for more than 20 minutes (pre-determined depends on system size).
2. No filter available + request for flushing.
3. Pressure transmitters are faulty or out of range.

Filter unit can be "Not Available" because it was taken offline or due to mechanical fault (as described in details in the "Standalone Filter Description").

## **4. Flush Cycle Stages:**

Filters are flushing as described in the single filter section.

The flush valve of the next filter open as soon as the flush valve of the previous filter turns off.

A complete Flushing Cycle is considered if all the available units finished the flush cycle.

## **5. Reset:**

Pressing on the Reset Push-button causes:

- a) Stop the current filter flush cycle and the sequence to the next filter.
- b) Clear Fault mode in both, filter and system levels.

## **6. Pause:**

Signal in the PAUSE input will stop the flush cycle (same as Reset). As long as this input is ON, the system will not enter a flush cycle.

## **7. Continuous Flushing mode:**

Continuous Flushing in system level means that the system is flushing in sequence and at least one filter unit is in flushing mode at all times, regardless of the DP across the system. The number of filters flushing simultaneously depends on the size of the system and the hydraulic conditions.

It is recommended to use the continuous mode for limited duration in order to prevent high wear of the filter internals.

- a. Manual operation of Continuous mode:  
Same as for single unit.
- b. Automatic operation of Continuous mode:  
Same as for single unit.

## HMI considerations:

### **1. The following information should be displayed on the HMI:**

- a. Current Inlet Pressure (PT1) - if applicable
- b. Current DP across the entire Filtration System
- c. Current System Status: Filtering; Flushing; Continuous Flushing; Alarm; Fault
- d. Current Status of each filter unit: Filtering; Flushing; Continuous Flushing; Fault
- e. Time from Last Flush and time to the next flush (by time)
- f. Cause of last flushing – DP / Time / Test / Remote
- g. Detail of Fault (Filter No., Limit Switch; Motor Time out...)
- h. Flush Counter
- i. Number of filters flushing together.

### **2. Parameters setting**

The following parameters values should be programmable via the HMI:

- Operating Method: Continuous / Time & DP / DP only
- Rest Flushing counter

Parameter	Units	Range	Default	Comments
a. DP Set point:	Bar(d) / psi (d)	0.1 – 0.7 / 1.5 - 10	0.5 / 7.0	
b. Minimum Inlet pressure:	Bar(g) / psi (g)	1.0 – 10.0 / 15 - 150	2.0 / 30	
c. Interval for flushing by time:	Minutes	1 – 1440	480	0 = Never
d. Time in HDP before Fault:	Minutes	1 – 60	5	
e. Delay before open XV1:	Seconds	0 – 12	1	
f. Delay before Start Motor:	Seconds	0 – 10	3	
g. Number of filter units flushing together:	Filter Units	1 - 4	2	Depends on system size
h. Time in Continuous - Manual	Minutes	0 - 240	60	
i. Time in Continuous – Auto.	Minutes	0 - 240	20	
j. No. of consecutive cycles	Cycles	1 - 10	3	
k. Interval for consecutive cycles	Minutes	0 - 10	5	

## **8. Installation Instructions**

## a. General

1. Before beginning the installation process, carefully read the safety instructions chapter of this document and make sure that all the workers at the installation site are fully aware of and comply with, these and any other local safety instructions.
2. If possible, prior to installing the filter, thoroughly flush the main line at the connection point in order to remove large objects that may damage the filter's internal mechanism.

## b. Mechanical installation

1. Locate the filter package near by the location in which the filters will be installed
2. Locate the filter at its intended operational location, level it so that the Inlet, Outlet and flushing flanges are aligned with the piping.
3. Connect and bolt all filter flanges to equivalent piping flanges.
4. Locate the relevant valves (Isolation, flushing etc.) in their position and orientation.

### **IMPORTANT!!**

It is required to prevent static back pressure or reverse flow through the filter therefore a non-return valve must be installed at the outlet of the filter.

5. Tighten the filter flange to piping flange as follows:

- If there are bolts and nuts - hold the bolt and tighten the nut where possible.
- Do not use power tools which are not torque adjustable.
- Can use electric or pneumatic tools adjusted to minimum torque and make final tightening by torque wrench.
- Both initial threading and final tightening to be done in criss- cross sequence as shown in the figure below.

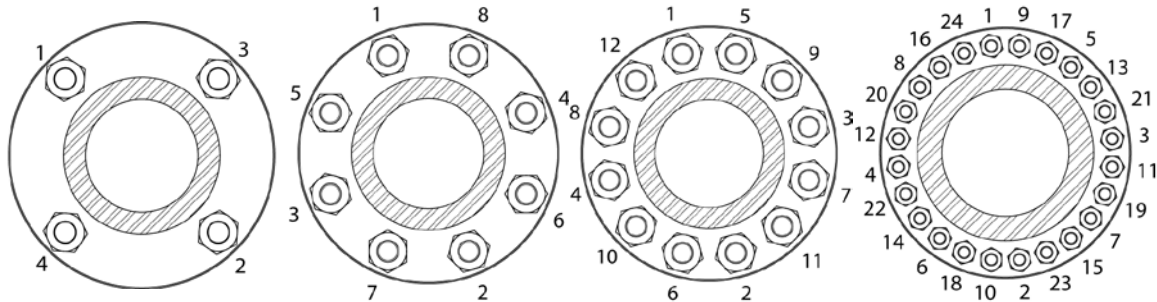

- Unless otherwise specified- use the torques below (Values based on closest metric bolts).

Size (UNC)	Torque (Nm)	Tension in bolt (N). For reference only.
1/4	9	9700
5/16	21	17000
3/8	42	28500
1/2	72	41500
5/8	174	78300
3/4	340	122500
1	580	176000

6. Perform final anchoring of filter legs to the base plate\ground.
7. The user should arrange suitable lighting in the vicinity of the filter to enable good visibility and safe maintenance.
8. The user should arrange suitable platforms and safety barriers to enable easy access to the filter without climbing on pipes and other equipment. All such equipment should comply with the safety clauses of the relevant local standards.

### **c. Electrical installation**

1. All electrical works at the installation site must be done by a qualified and authorized electrician only. Make sure that this electrician is fully aware of all the relevant safety instructions, is familiar with the electrical design of the system and has in hand the relevant approved wiring diagrams.
2. Recommendation for the connection of the power supply cable to the motor:
  - Connect the power cable to the drive unit using a long enough cable to allow the drive units to be removed and placed near the filter for maintenance, without having to disconnect them from the cable.
  - The installation of this power cable is considered as a "high" voltage connection and its connection should be performed according to the relevant local or national electrical codes for such a connection.
3. Recommendation for the connection of Control instruments:
  - Prior to the connection it is recommended to review the data sheets of the relevant instruments and review their connection diagrams
  - The connection of the control instruments to the control system must be performed according to the accepted and approved wiring diagram.

### **d. Pneumatic installation**

1. The pneumatic connection in the case of the OMEGA filters for this system refers only to the Actuators of the flushing valves.
2. Prior to the connection of the air supply to the solenoids, it is recommended to review the data sheets of the solenoid and verify the connection type for the air supply (dimension and threading)
3. Make sure that air supply to the filter is regulated and dried and featured with a pressure release mechanism.
4. Connect the piping according to the local standards and requirements.

## **9. Commissioning, Start-up and First Operation**

## a. Commissioning & Start – Up

### Pre-Commissioning:

Step	Action	Comments	Confirm
1.	Verify that all piping is connected and tightened		
2.	Verify that inlet, outlet and drain valves are closed		
3.	Verify that power and control wiring are completed.	Power supply is available but disconnected.	
4.	Verify that compressed air is connected to the Flush Valves.	Compressed air is available but disconnected	
5.	Turn ON the control Power. Power for the motors should be on “Manual” at this stage		
6.	Operate momentarily motor No.1 forward and verify it is turning CCW and moving upward	Switch phase order if required	
7.	Operate momentarily motor No.1 backward and verify it is turning CW and moving downward	Correct wiring if required	
8.	Operate the motor up or down and bring it to the middle way between the proximity switches	Make sure to have eye contact between the motor and the operator.	
9.	Manually activate Top Limit Switch and verify it is connected to the correct PLC input		
10.	Manually activate Bottom Limit Switch and verify it is connected to the correct PLC input		
11.	Repeat steps 5 to 9 with all motors		
12.	Open compressed air supply to Flush Valve No. 1 and verify it remains closed		
13.	Activate Solenoid SV1 by forcing its Output and verify the valve opens		
14.	Repeat steps 12 & 13 with Flush Valve No.2		
15.	Initiate “dry” Flush Cycle from local Control panel or from HMI and follow the sequence.	For details, refer to the Control Philosophy section	
16.	Simulate “Motor Time Out” Fault for all motors	For details, refer to the Control Philosophy section	
17.	Simulate “Proximity Switch” Fault for all drive-units sets.	For details, refer to the Control Philosophy section	
18.	Simulate “Direction Fault” for all drive-units sets.	For details, refer to the Control Philosophy section	
19.	Simulate “Flush Valve failures” for both flush valves	For details, refer to the Control Philosophy section	
20.	Check analog signals and verify correct reading on the HMI		



### Commissioning:

Step	Action	Comments	Confirm
1.	Open the Vent Valve at N7		
2.	Slightly open the Inlet valve (N1) and fill the filter gradually until water is coming out from N7		
3.	Close the Vent Valve at N7		
4.	Open the inlet valve completely		
5.	Verify that the pressure in the filter is within the designed working pressure of the filter	Check for leaking and repair if required	
6.	Initiate manual full flush cycle	Verify opening of the correct flush valve. Check for leaking and repair if required	
7.	Turn the system into continuous flushing mode and start to open the outlet valve at N2	Watch the DP across the filter and make sure DP value not exceed 30 kPa. In case DP is higher, slightly close the downstream valve to reduce the flow.	
8.	Repeat the above with the other filters.	Steps 1 to 7.	
9.	Bring the system to its designed working flow rate		
10.	Switch off the continuous flushing mode and turn it to work according to DP with time backup of 6 hours.		
11.	Simulate HDP and HHDP conditions and verify the reaction of the control system	For details, refer to the Control Philosophy section	
12.	Follow and study the system functioning for fine tuning of the flushing interval, and DP set points.		

### Shutoff Procedure:

1. Prior to system shutoff it is highly recommended to initiate manual flush cycle
2. ALWAYS, close outlet valve before closing the inlet valve.
3. Release the pressure by opening the vent valve.
4. It is recommended to leave the filter full with water in order to minimize the oxygen exposure. However, since these filters are made out of Titanium, this issue is less critical.
5. In order to prevent biofilm growth on the screens and filter walls, it is recommended that the filter will be stored with chlorinated water at about 1 ppm.

## **10. Part Schedule**

## a. Main - Omega 27K / 36K

### Parts List

**Please note** – Cat. Numbers are for reference only. For spare parts ordering please refer to the specific O&M provided with the filter. For assistance, please provide the filter serial number and /or catalogue number or Order Confirmation number.

ITEM NO.	CAT. NO.	DESCRIPTION	QTY. 27K	QTY. 36K	MATERIAL
<b>1</b>		<b>OMEGA 27K / 36K Housing</b>	1	1	C/St
1.1	770103-000236	28" Gasket	1	1	NBR
1.2		Omega 27K / 36K Lid	1	1	C/ST
1.3	760101-000845	M27 X 150 Bolt	24	24	S/ST 316
1.3.1	760103-000104	M27 Flat Washer	48	48	S/ST 316
1.3.2	760103-000290	M27 Flat Polymeric Washer	48	48	NYLON
1.3.3	760102-000130	M27 Nut	24	24	S/ST 316
1.4	730108-000113	3/4" Air Release Valve	1	1	PP
1.4.1	730104-000221	3/4" Ball Valve	1	1	S/ST 316
1.4.2		3/4" Fitting	1	1	S/ST 316
1.5	710102-002639	Transmission Gear Cover	1	1	S/ST 316L
1.5.1	760101-000609	M8 X 20 Bolt	4	4	S/ST316
1.5.2	710102-002618	Transmission Cover's Bracket	4	4	S/ST 316
1.5.3	760103-000096	M8 Flat Washer	4	4	S/ST 316
1.6	710102-002520	3" Flange With Instrumentations Ports	2	2	S/ST 316L
1.6.1	770103-000165	2.5" Gasket	2	2	NBR
1.6.2	760101-000627	M16 X 80 Bolt	8	8	S/ST 316
1.6.3	760103-000128	M16 Flat Washer	16	16	S/ST 316
1.6.4	760103-000229	M16 Flat Polymeric Washer	16	16	NYLON
1.6.5	760102-000127	M16 Nut	8	8	S/ST 316
1.7	740102-000593	2" Blind Flange With 3/4" Port	1	1	S/ST 316L
1.7.1	770103-000146	2" Gasket	1	1	NBR
1.7.2	760101-000625	M16 X 70 Bolt	4	4	S/ST 316
1.7.3	760103-000128	M16 Flat Washer	8	8	S/ST 316
1.7.4	760103-000229	M16 Flat Polymeric Washer	8	8	NYLON
1.7.5	760102-000127	M16 Nut	4	4	S/ST 316
<b>3</b>		<b>Proximity Switches Assembly</b>	1	1	
3.1	710103-005559	Proximity Switches Sling	1	1	S/ST 316L
3.1.1	760101-001209	M10 X 20 Cap Screw	1	1	SST316
3.1.2	760103-000143	M10 Spring Washer	1	1	S/ST 316
3.1.3	760103-000097	M10 Flat Washer	1	1	S/ST 316
3.2	720302-000138	Inductive Proximity Sensor	2	2	S/ST 316
3.3	710105-003833	Proximity Switches' Plate	1	1	ST.37-2
3.3.1	760101-000697	M6 X 20 Socket Set Screw	3	3	S/ST 316
3.3.2	760103-000109	M6 Spring Washer	3	3	S/ST 316
3.3.3	760103-000094	M6 Flat Washer	3	3	S/ST 316
<b>4</b>	<b>710103-005642</b>	<b>Transmission Gear's Lead Rod</b>	2	2	S/ST 316
4.1	760103-000125	M12 Flat Washer	2	2	S/ST 316
<b>5</b>	<b>720202-000074</b>	<b>Transmission Gear</b>	1	1	Various

ITEM NO.	CAT. NO.	DESCRIPTION	QTY. 27K	QTY. 36K	MATERIAL
5.1	710103-005475	Cardan Joint	6	6	AISI 304
5.1.1	710103-005479	Clevis Pin ( Shaft to Cardan)	12	12	S/ST 316
5.1.2	760105-000066	2.5X12 Split Pin	6	6	S/ST316
5.1.3	760105-000052	R-Clip	6	6	S/ST 316
5.2	710103-005332	Drive Bushing	1	1	Phosphor bronze SAE 65
5.2.1	760101-000696	M6 X15 Cap Screw	4	4	S/ST 316
<b>6</b>	<b>710103-005505</b>	<b>Bearing Housing</b>	1	1	S/ST.316L
6.1	770102-000123	O-Ring P2-234	1	1	NBR
6.2	760104-000262	M12X60 Stud Bolt	4	4	S/ST 316
6.2.1	760103-000125	M12 X 2.5 Flat Washer	4	4	S/ST 316
6.2.2	760102-000088	M12 NUT	4	4	S/ST 316
<b>7</b>		<b>Sealing Flange Assembly</b>	6	6	
7.1	710103-005631	Sealing Flange	6 X 1	6 X 1	S/ST 316L
7.2	710103-005630	Upper Clamp Sleeve	6 X 1	6 X 1	Delrin
7.3	770102-000153	O-Ring P2-343	6 X 1	6 X 1	NBR
7.4	770102-000145	O-Ring P2-331	6 X 1	6 X 1	NBR
7.5	760104-000261	M12 X 50 Stud Bolt	6 X 4	6 X 4	S/ST 316
7.5.1	760102-000088	M12 Nut	6 X 4	6 X 4	S/ST 316
7.5.2	760103-000125	M12 X 2.5 Flat Washer	6 X 4	6 X 4	S/ST 316
7.6	760101-001224	M6 Eye Bolt	6 X 1	6 X 1	S/ST 316
7.7	710103-005640	Sealing Insert	6 X 1	6 X 1	S/St 316L + Delrin
7.8	770101-000031	O-Ring 24 X 3	6 X 1	6 X 1	NBR
7.9	770104-000231	Wiper Seal for Scanner Shaft	6 X 1	6 X 1	Polyurethane
7.10	770101-000027	O-Ring 14 X 3	6 X 1	6 X 1	NBR
<b>8</b>	<b>710103-005307</b>	<b>Upper Clamp</b>	6	6	Delrin
8.1	770102-000152	O-Ring P2-342	6	6	NBR
8.2	770102-000123	O-Ring P2-234	6	6	NBR
<b>9</b>		<b>SLN Suction Scanner Assembly - Short</b>	6		Various
<b>9</b>		<b>SLN Suction Scanner Assembly - Long</b>		6	S/ST 316
9.1		Scanner Shaft	6	6	S/ST 316
9.1.1	760105-000063	Dowel Pin 8X30	6	6	Delrin
9.1.2	710103-005510	M10 Threaded Plug	6 X 12	6 X 16	Various
9.2	700190-004688	SLN Kit	6 X 12	6 X 16	PP
9.2.1	710101-001247	SLN Saddle	6 X 12	6 X 16	NBR
9.2.2	770102-000095	O-Ring P2-128	6 X 12	6 X 16	PP
9.2.3	710101-001252	SLN Saddle Locker	6 X 12	6 X 16	PP
9.2.4	710101-001325	SLN Rear Washer	6 X 24	6 X 32	Polyurethane
9.2.5	710101-001281	SLN Seal	6 X 12	6 X 16	PP
9.2.6	710101-001326	SLN Rear Washer Cover	6 X 12	6 X 16	S/ST 316
9.2.7	760107-000103	SLN Spring	6 X 12	6 X 16	PP
9.2.8	710101-001319	SLN Body	6 X 12	6 X 16	PP
9.2.9	710101-001324	SLN Front Washer	6 X 12	6 X 16	Delrin
9.2.10	710101-001322	SLN Nut	6 X 12	6 X 16	
9.3		<b>Scanner Stopper</b>	6	6	Delrin

ITEM NO.	CAT. NO.	DESCRIPTION	QTY. 27K	QTY. 36K	MATERIAL
9.3.1		Stopper 52mm with Male Thread	6 X 1	6 X 1	Delrin
9.3.2		Stopper 52mm with Female Thread	6 X 1	6	Various
<b>10</b>		<b>Weavewire 4500SQ CM Screen</b>	6		S/ST 316
<b>10</b>		<b>Weavewire 6000SQ CM Screen</b>		6	S/ST 316
10.1	770104-000080	Hydraulic Seal AM-05 EPDM	2 X 6	2 X 6	EPDM
<b>11</b>	<b>710103-005306</b>	<b>Bottom Clamp</b>	6	6	Delrin
11.1	770102-000407	O-Ring P2-369	6 X 1	6 X 1	NBR
11.2	770102-000170	O-Ring P2-439	6 X 1	6 X 1	NBR

Parts Drawing

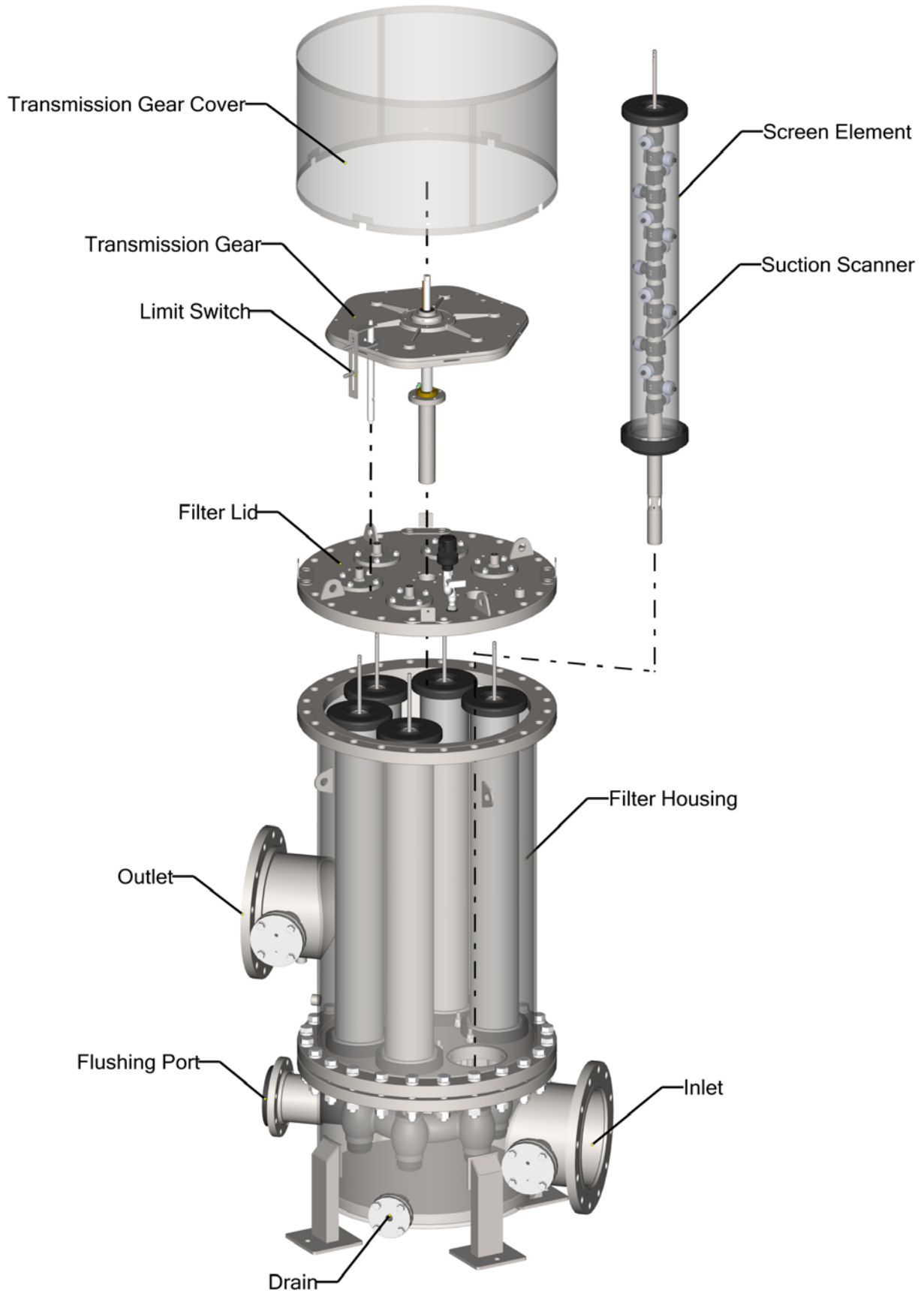

Parts Drawing - Continue

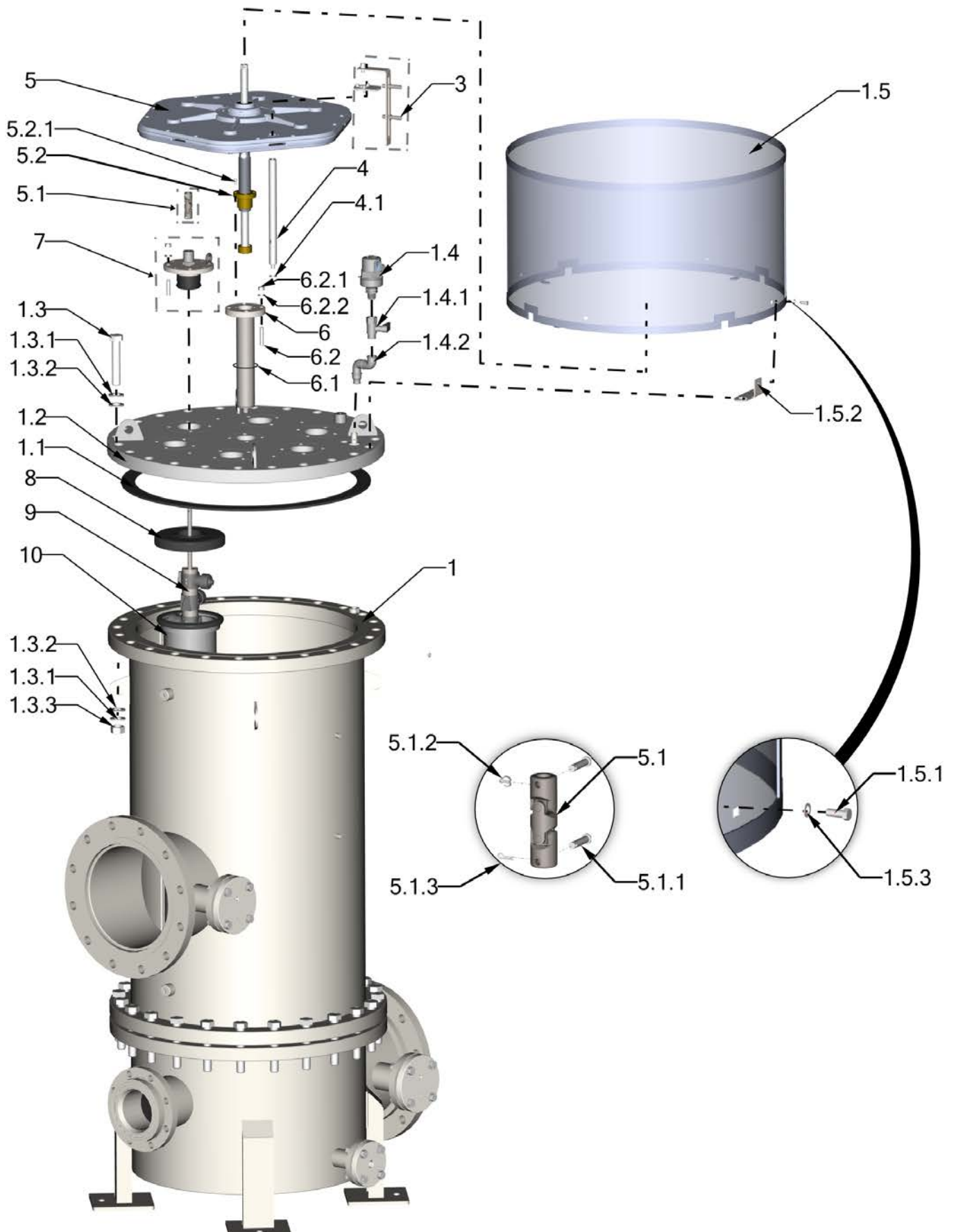

Parts Drawing - Continue

3. Proximity Switches Assembly

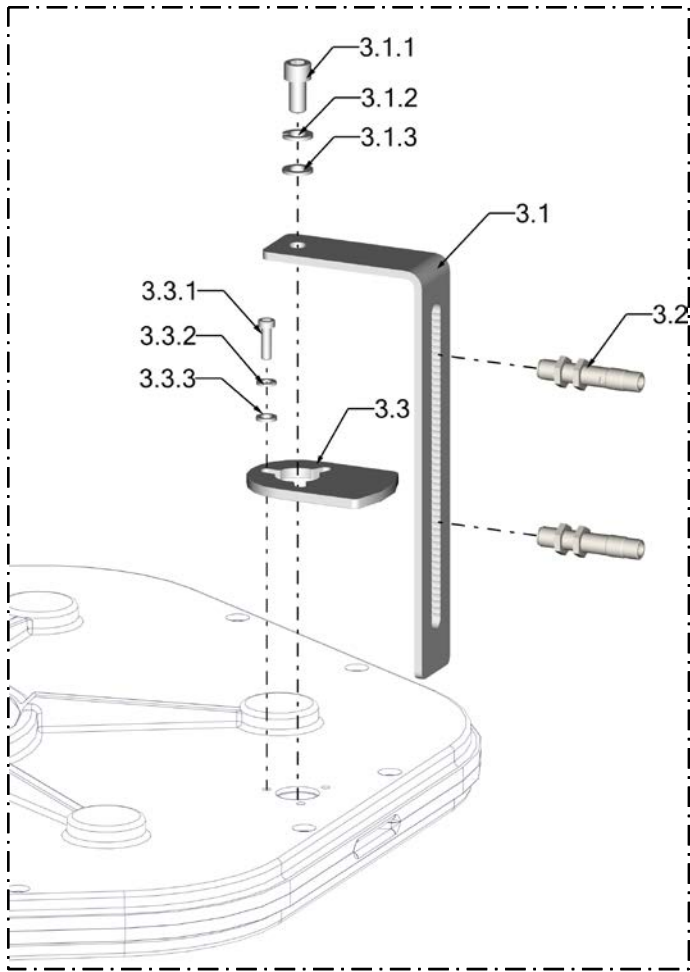

7. Sealing Flange Assembly

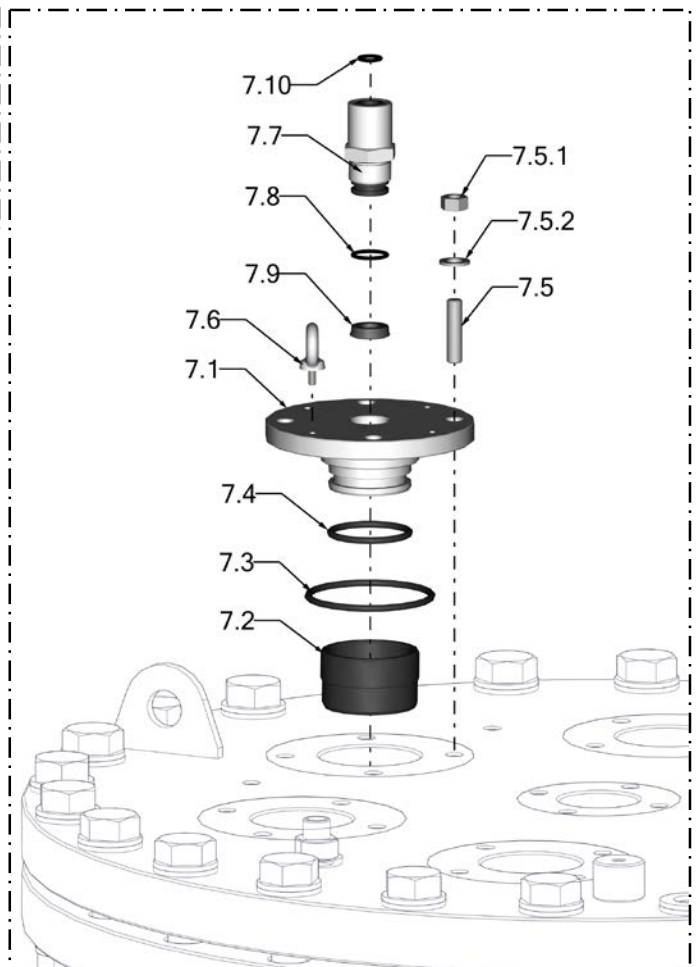



Parts Drawing - Continue

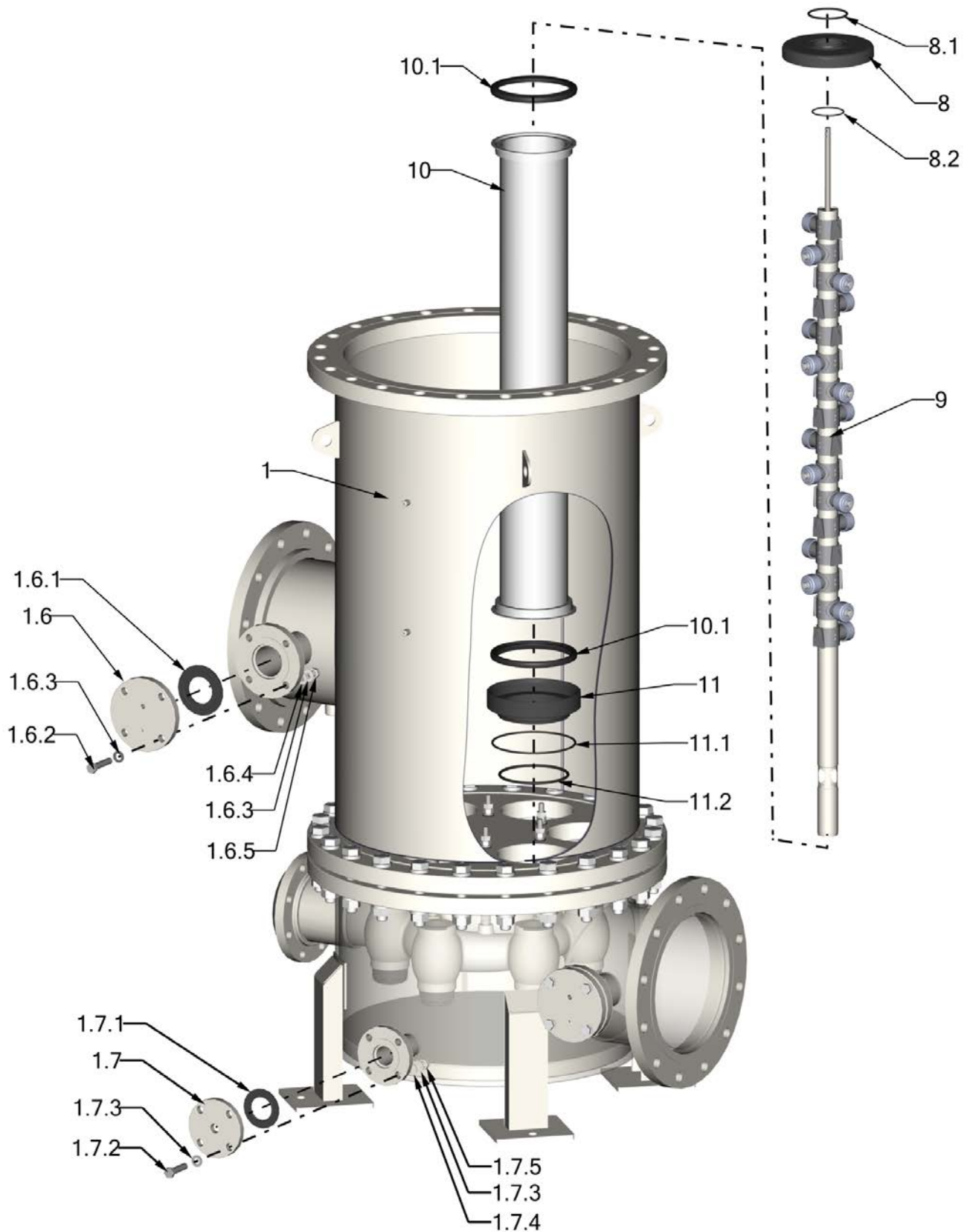

Parts Drawing - Continue

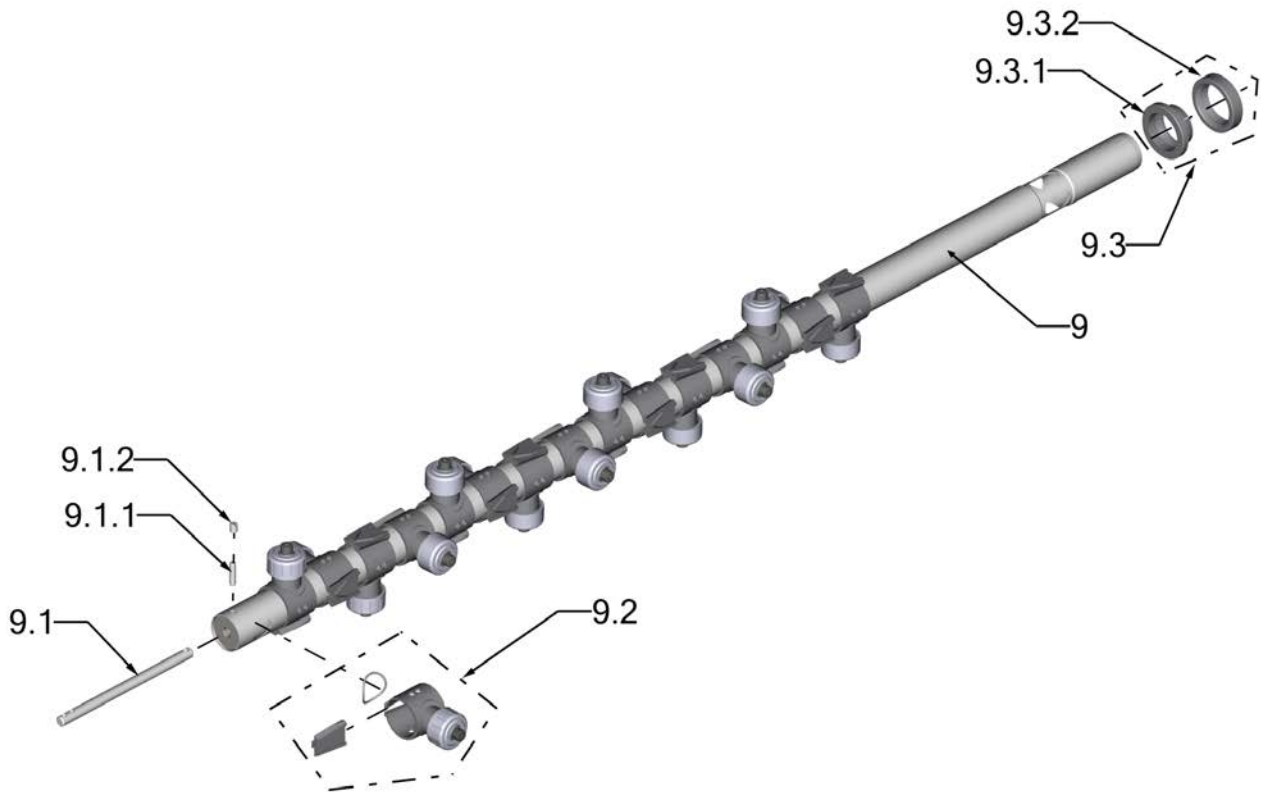

9.2 SLN Assembly SW for OMEGA

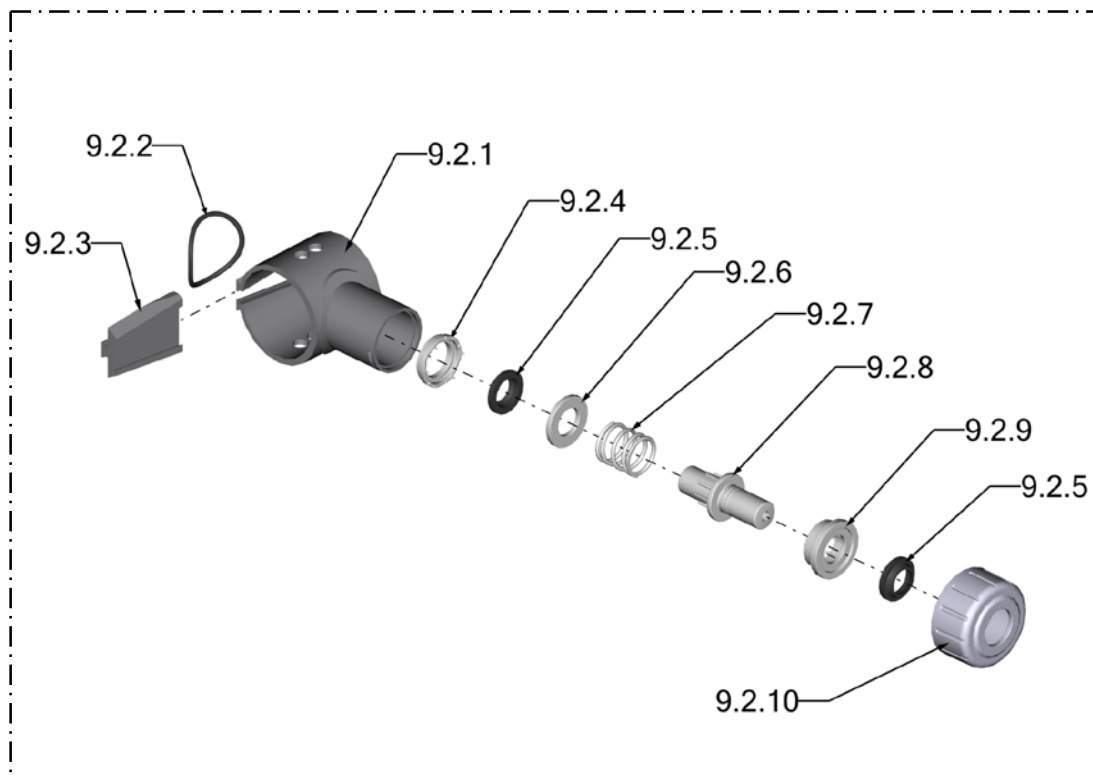

## b. Drive Unit - Omega 27K / 36K

### Parts List

**Please note** – Cat. Numbers are for reference only. For spare parts ordering please refer to the specific O&M provided with the filter. For assistance, please provide the filter serial number and /or catalogue number or Order Confirmation number.

ITEM NO.	CAT. NO.	DESCRIPTION	QTY	MATERIAL
<b>2</b>		<b>Drive Unit Assembly</b>	<b>1</b>	<b>Various</b>
2.1		Motor 0.75KW 400/460V 50/60HZ 1400 RPM	1	Various
2.2		Worm Gear 1/40	1	Aluminum
2.2.1	760101-000724	M10 X 40 Set Screw	4	S/ST 316
2.2.2	760103-000097	M10 Flat Washer	4	S/ST 316
2.2.3	760103-000143	M10 Spring Washer	4	S/ST 316
2.2.4	760102-000087	M10 Hex Nut	4	S/ST 316
2.2.5		Plastic Cover	1	PVC
2.2.6	760101-000700	M8 X 20 Cap Screw	4	S/ST 316
2.2.7	760103-000096	M8 Flat Washer	4	S/ST 316
2.3	710103-005211	Drive Shaft Key	1	Brass

## Drive Unit Assembly

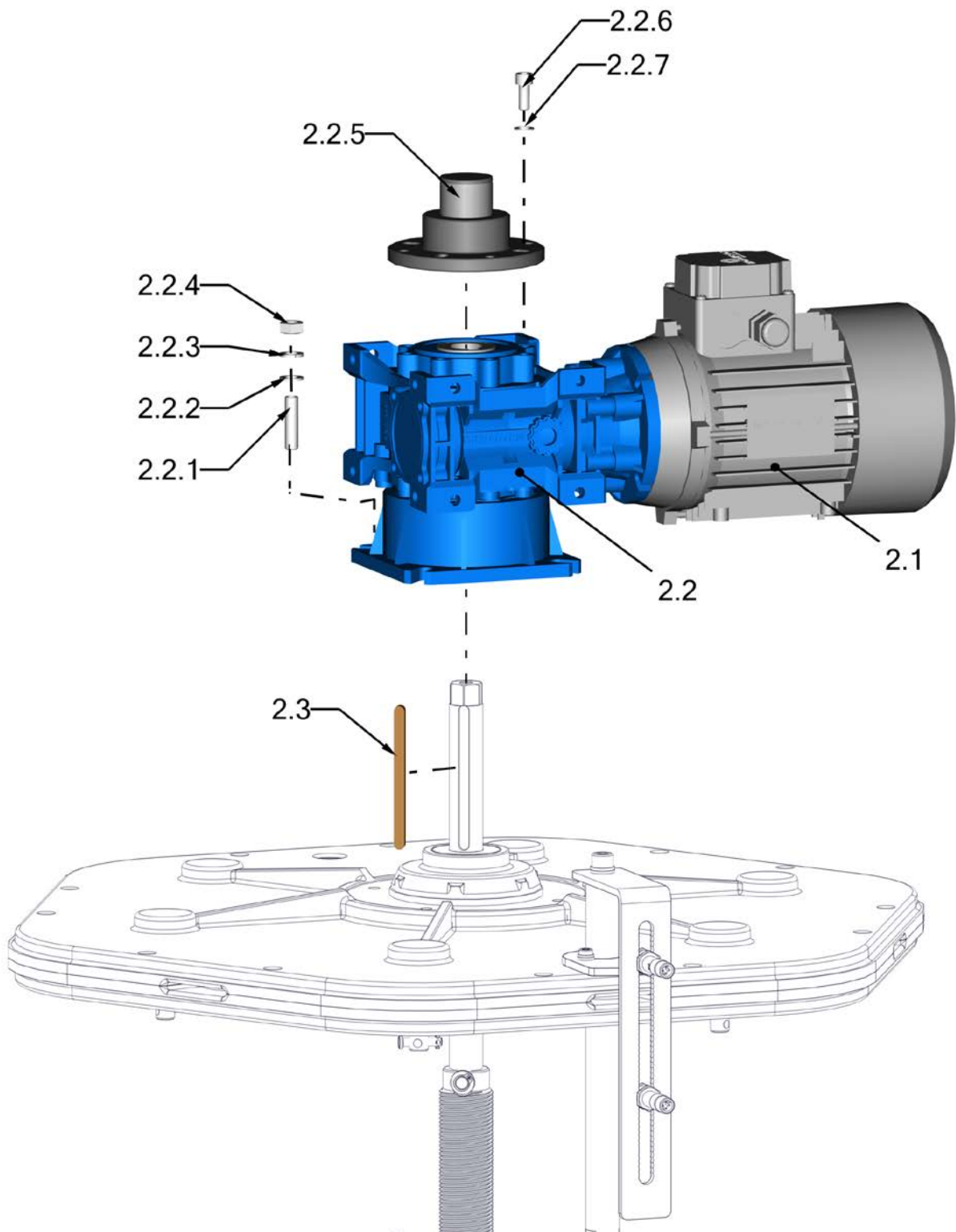

## c. Control Parts - Package 1

### Part List

**Please note** – Cat. Numbers are for reference only.

For spare parts ordering please refer to the specific O&M provided with the filter. For assistance, please provide the filter serial number and /or catalogue number or Order Confirmation number.

ITEM NO.	CAT. NO.	DESCRIPTION	QTY.	MATERIAL
1.8	730104-000231	3/4" Ball Valve	1	Brass
1.8.1	780101-000877	3/4" Nipple	1	S/ST 316
20	700190-004696	Junction Box	1	Various
21	700190-002618	Pressure Differential Switch (Midwest)	1	Various
21.1	720501-000213	5/16"x1/8" Connector	1	Brass
21.2	720501-000213	5/16"x1/8" Connector	1	Brass
22	720301-000040	Pressure Gauge	1	Brass
22.1	730104-000202	1/4" 3-Way Valve	1	Brass
22.2	720501-000204	5/16" X 1/8" L-Connector	1	Brass
22.3	720501-000204	5/16" X 1/8" L-Connector	1	Brass
22.4	720501-000202	5/16" X 1/4" L-Connector	1	Brass
22.5	720501-000214	1/4" T-Connector	1	Brass
22.6	700190-002336	1/4" Manometer Valve	1	Various
23	720501-000214	1/4" T-Connector	1	Brass
23.1	720501-000202	5/16" X 1/4" L-Connector	1	Brass
23.2	720501-000206	5/16" X 1/4" Connector	1	Brass
23.3	780101-000400	1/4" Bushing	1	Bronze
24	720502-000036	5/16" Nylon Tube	1 m	NYLON

## Control Parts Assembly

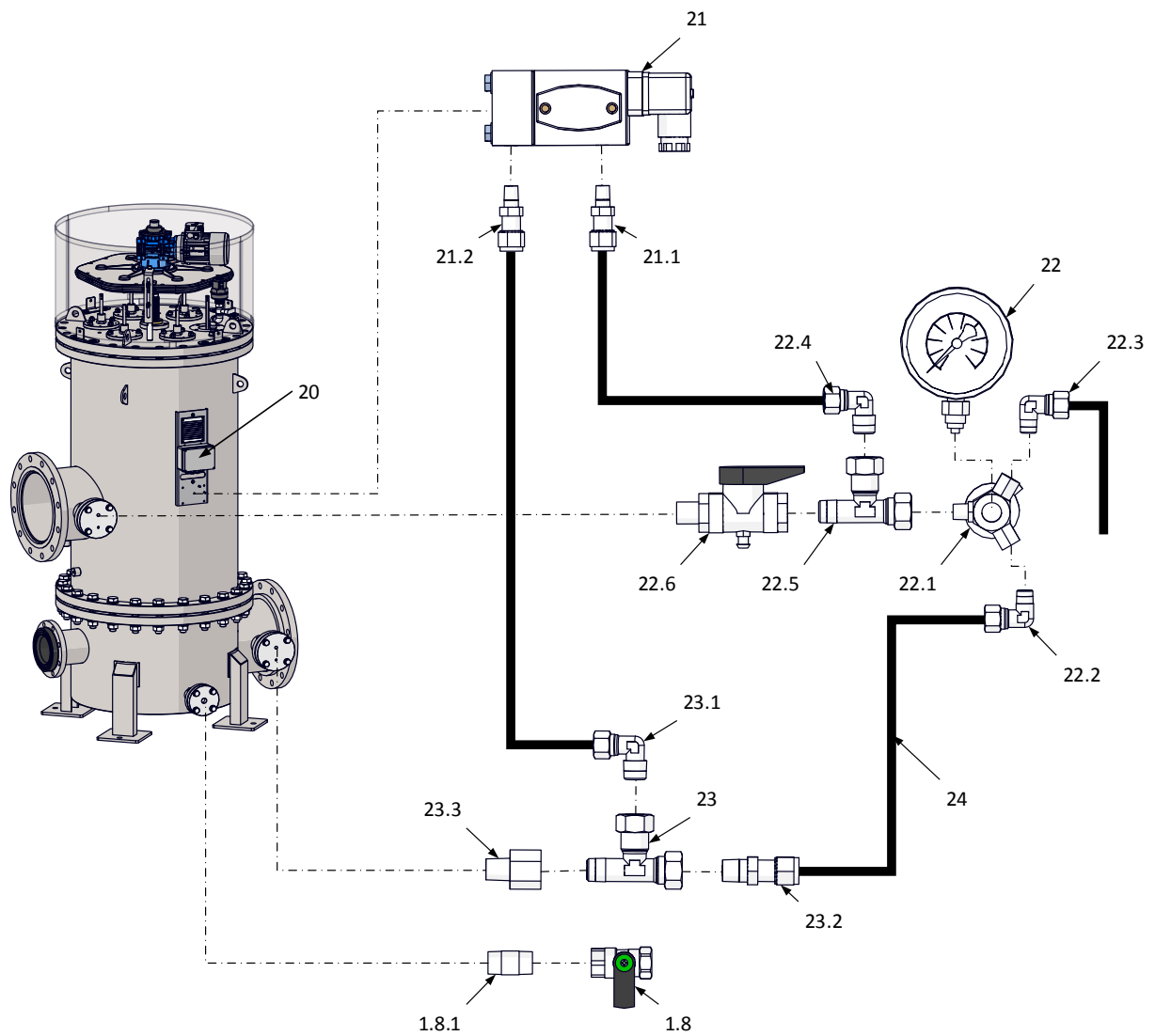

### d. Flushing Valve- 4" (DN100) with adapter

#### Part List

**Please note** – Cat. Numbers are for reference only.

For spare parts ordering please refer to the specific O&M provided with the filter. For assistance, please provide the filter serial number and /or catalogue number or Order Confirmation number.

ITEM NO.	CAT. NO.	DESCRIPTION	QTY.	MATERIAL
30		4" Pneumatic Butterfly Valve	1	Various
31	700105-001571	4"/ 6" Adapter	1	PP

#### Flushing Valve Assembly

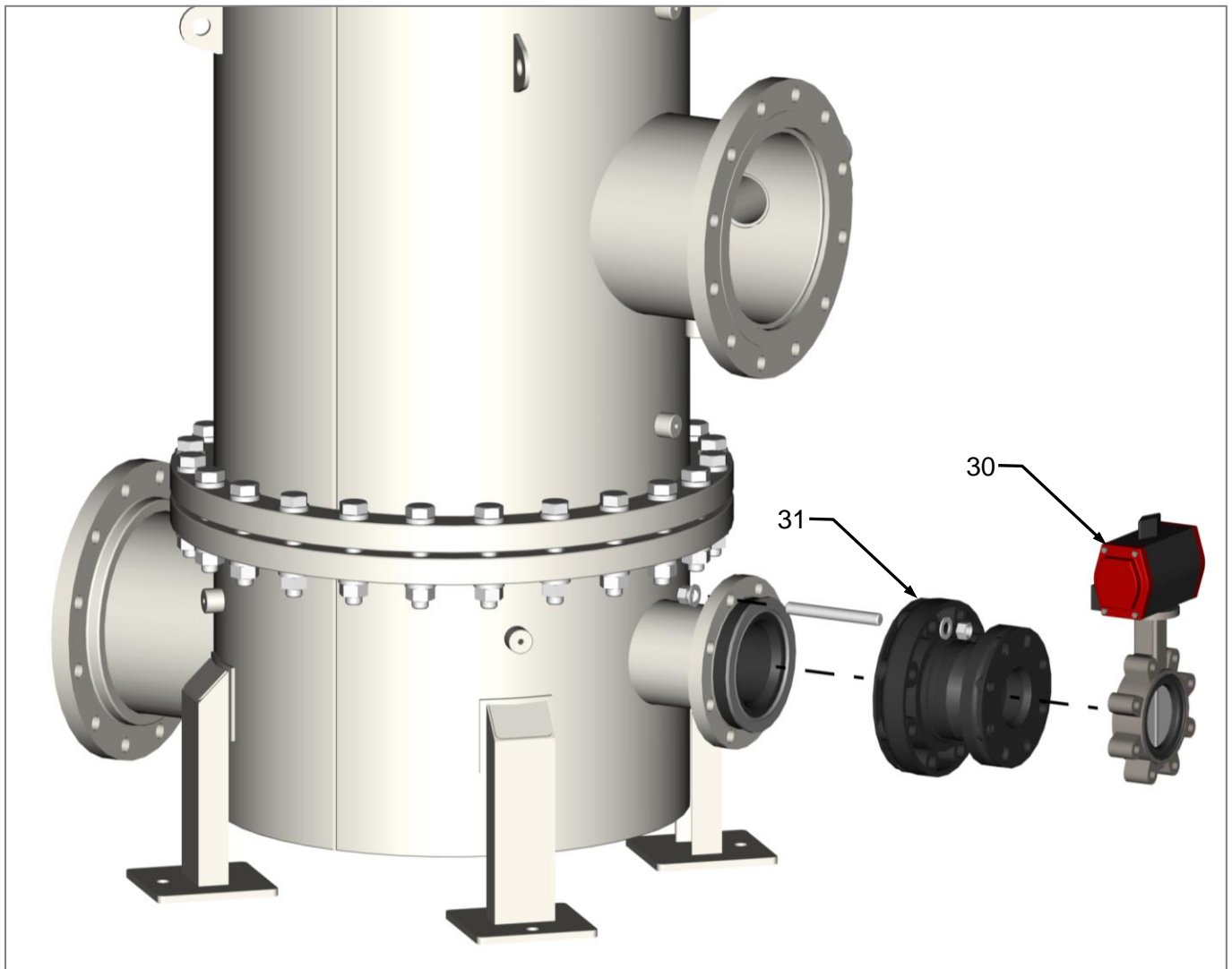

## d. Flushing Valve- 6" (DN150)

### Part List

**Please note** – Cat. Numbers are for reference only.

For spare parts ordering please refer to the specific O&M provided with the filter. For assistance, please provide the filter serial number and /or catalogue number or Order Confirmation number.

ITEM NO.	CAT. NO.	DESCRIPTION	QTY.	MATERIAL
30	730105-000688	6" Pneumatic Butterfly Valve BRAY	1	Various
30.1		Bray Actuator	1	Various
30.2		6" Bray Butterfly Valve	1	Various
32	720103-000289	ASCO Solenoid SCB320A202 3/2 NC 24DC	1	Various
32.1	720501-000252	NIPPLE 1/4"MX1/4"M 122H	1	S/ST316
32.2	720501-000271	QUICK L-CONNECTOR 1/4"X8MM	1	Various

### Flushing Valve Assembly

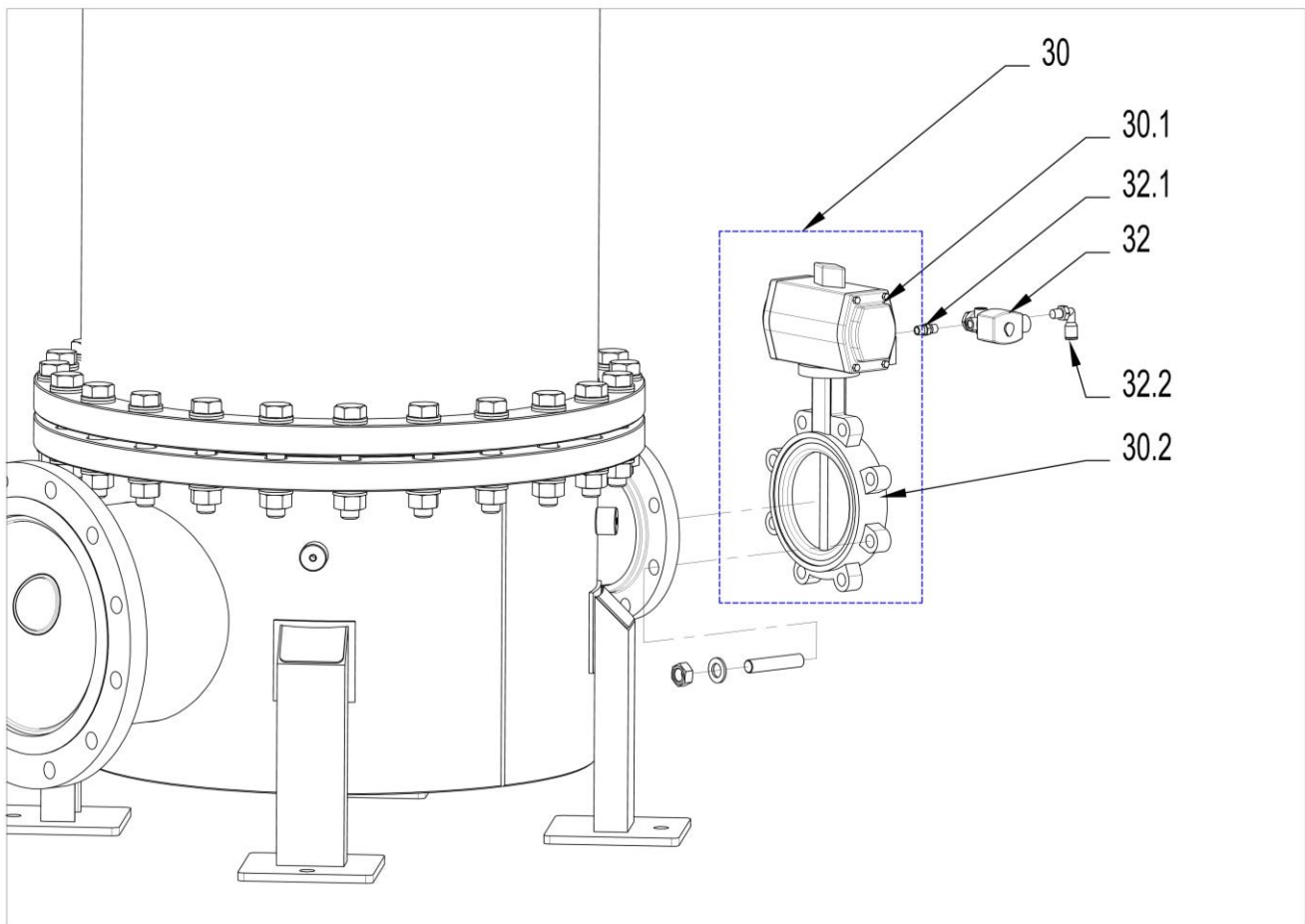



# 11. Maintenance

## a. Equipment and Materials

### Auxiliary materials

Materials will appear in the document by their ID.









ID	Material Description	Figure
ML-1	<p>Thread locking Loctite 243</p> <p>Used to lock bolts to avoid openings due to vibration</p>	
ML-2	<p>Silicone Grease MOLYKOTE PG 21</p> <p>Used for O-ring lubrication</p>	
ML-3	<p>Multi-Purpose Grease MOLYKOTE FB 180</p> <p>for lubrication of drive-shaft and motor key</p>	
ML-4	<p>Silicone Spray H1</p> <p>for lubrication of seals and gaskets</p>	
ML-5	<p>Anti-Seize Grease WEICON ASW 450</p> <p>prevent seizing of stainless steel bolts and nuts</p>	

Table 1 - Materials List

## Tools and Equipment

Tools and Equipment will appear in the document by their ID.

ID	Tool / Jig Description	Figure
TL-1	Seal Extractor	
TL-2	Hex Key (Allen): 4, 5, 6, 8, 10mm	
TL-3	Hex Sockets (1/2" drive): 10, 12, 13, 14, 15, 16, 17, 18, 20, 21, 22, 27, 30, 33, 36, 41 mm	
TL-4	Hex Long Sockets (1/2" drive): 22 mm	
TL-5	Hex Socket Wrench Extensions (1/2" drive): 1200mm 100-200mm	
TL-6	1/4" Drive Short Ratchet	
TL-7	1/4" Drive Short Extension	
TL-8	Flexible Joint (1/4" Drive)	
TL-9	Allen Bit (1/4" Drive): 4, 5, 6, 8mm	









ID	Tool / Jig Description	Figure
TL-10	Combination Wrench: 10, 12, 13, 14, 15, 16, 17, 18, 20, 21, 22, 27, 30, 33, 36, 5/8, 7/8	
TL-11	Flat Screw Driver: 6mm wide	
TL-12	Long Nose Plier	
TL-13	Pin Punch: 3mm, 5mm, 6mm, 8mm	
TL-14	IRON Hammer: 1kg	
TL-15	Eye Bolt: M6 x3, M10 x3, M12 x3	
TL-16	Seal Extractor	
TL-17	Open End Torque Wrench: Torque Range: 7-1350 Ft-Lb	
TL-18	Tight-Access Offset Sockets (1/2" Square Drive): 5/8, 7/8, M12.	
TL-19	Lifting Device with Minimum lifting capacity of 1500 Kg	

Table 2 - Tools and Equipment List

## **b. General inspection**

The maintenance requirements of automatic Self-Cleaning Filters are directly related to their Flushing frequency. Flushing frequency depends on water quality (Suspended Solids and Chemistry) and flow rate. Therefore, the frequency of scheduled routine maintenance activities should be determined during the commissioning and first few months of operation, and should not surpass 6 months.

It is recommended to follow-up on the flushing frequency and the DP trend of the system and inspect the filters when an un-usual change is recognized.

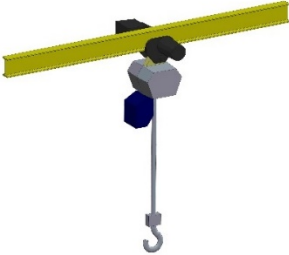
It is also recommended to include the filters in the routine equipment inspection “tours” of the plant, in order to find and treat any leakage or damage as early as possible.

## **c. Routine inspection**

For this routine inspection, it is possible to remove the Transmission gear cover (1.5 in Parts List) which enables access to the drive mechanisms.

1. Launch flush cycle by simulating DP or by manual start.
2. Verify that the Flushing Valve is open.
3. Verify that the Transmission Gear move upwards/ downwards.
4. Verify that the Flushing Valve is close at the end of the cycle.
5. Take care of any leakage from the Sealing Nuts (7.7). If necessary, replace its Internal O-Rings (See instructions in the next chapter).

## **d. Annual maintenance**

A thorough maintenance operation is conducted once every year or when the filter has completed about 50,000 flush cycles.

Before beginning any maintenance procedure, carefully read the safety instructions of this document and make sure that the staff is fully aware of, and comply with these and any other relevant local safety instructions.

The thorough maintenance operation will include the following operations:

1. Filter Disassembly according to section **f**.
2. Visual inspection and evaluation of screens. Thorough cleaning instructions can be found below at section **e**. Replacement is required only if there are signs of mechanical damage to the screen.
3. Replace shaft sealing set according to section **g**.
4. Inspect and maintain Suction Scanner according to section **h**.
5. Filter Assembly according to sections **i**.
6. Restart the filter according to section **k**.

### e. Screen COP (Clean-Out-of-Place)

Screens cleaning is required as part of the maintenance procedure or in case the filtration system is significantly clogged. In most cases cleaning with high pressure washer is sufficient.

- a) Wash the Screens with high pressure washer.
- b) Rinse the Screens from outside-in, and then rinse their interior surface.
- c) Check the Screens for clogged surface and any mechanical damage, using a strong flashlight.

#### **Dissolved precipitates and scale:**

If the Screen is clogged with dissolved precipitants that cannot be removed by the pressure washing, chemical treatment is required.

Chemical or detergent selection depends on precipitants origin. Mineral or Organic.

#### **Acid treatment:**

Used for dissolving Calcium Carbonate, Magnesium Carbonate compounds, Iron and Manganese Oxides. Most of the mineral acids are suitable for the treatment (as long as they do not contain gypsum). The common ones are:

- Hydrochloric acid (HCL)
- Sulfuric acid (H<sub>2</sub>SO<sub>4</sub>)

It is recommended to dilute the acid to a concentration of about 2% in which case the acid is still effective but is less dangerous.

Remove the seals from the Screen cylinder and soak it in the solution for 10 – 20 minutes (depending on the amount and kind of precipitates).

The Screen should then be checked, if the Screen is not clean, continue with the process for additional 10 – 20 minutes.

If the Screen is clean, wash it thoroughly with clean water.

#### **Organic and Biofilm Removal:**

Organic Compounds and Biofilm can be cleaned with Sodium Hypochlorite (NaClO) solution or Calcium chlorite (CaClO<sub>2</sub>) at 0.5%, for about 2 minutes. If the Screen is not clean, continue with the process for additional 2 minutes.

If the Screen is clean, wash it thoroughly with clean water.

---

**WARNING!** *The above chemicals are harmful to people and equipment. Read and follow manufacturer's instructions and MSDS. Use ALL precautions and protective gear when working with the Chemicals to prevent contact with skin, eyes & mouth.*

---

## f. Dismantling filter components

Opening the filter and disassembling its inner components is necessary for replacing screens, periodic maintenance and repairs.

The following instructions apply for Omega 13.5K, 18K, 27K and 36K

### Preparation:

1. Initiate a manual flush cycle
2. Verify that the Transmission Gear have reached the top limit position.
3. Disconnect power supply to the filter and lock the relevant switches.
4. Close and secure Inlet and Outlet Valves.
5. Empty the filter by opening Drain Valve and Flushing Valve. Allow air getting into the filter through the Air Release Valve.
6. When filter is empty, close the Flushing Valve and disconnect air supply.

### Dismantling Steps:

7. Remove Transmission Gear Cover Screw's sets (1.5.1)+(1.5.3).
8. Lift Transmission Gear Cover (1.5) and place it aside.

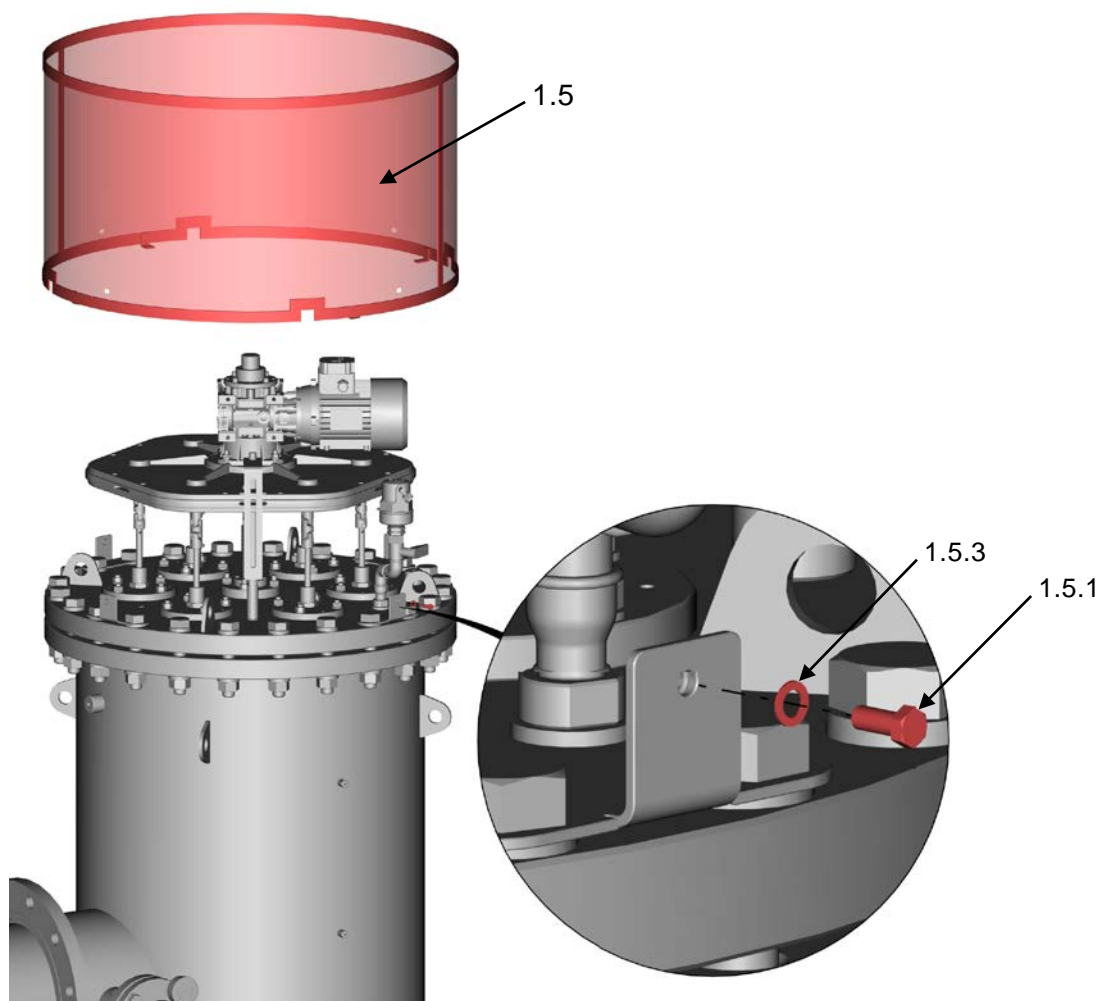
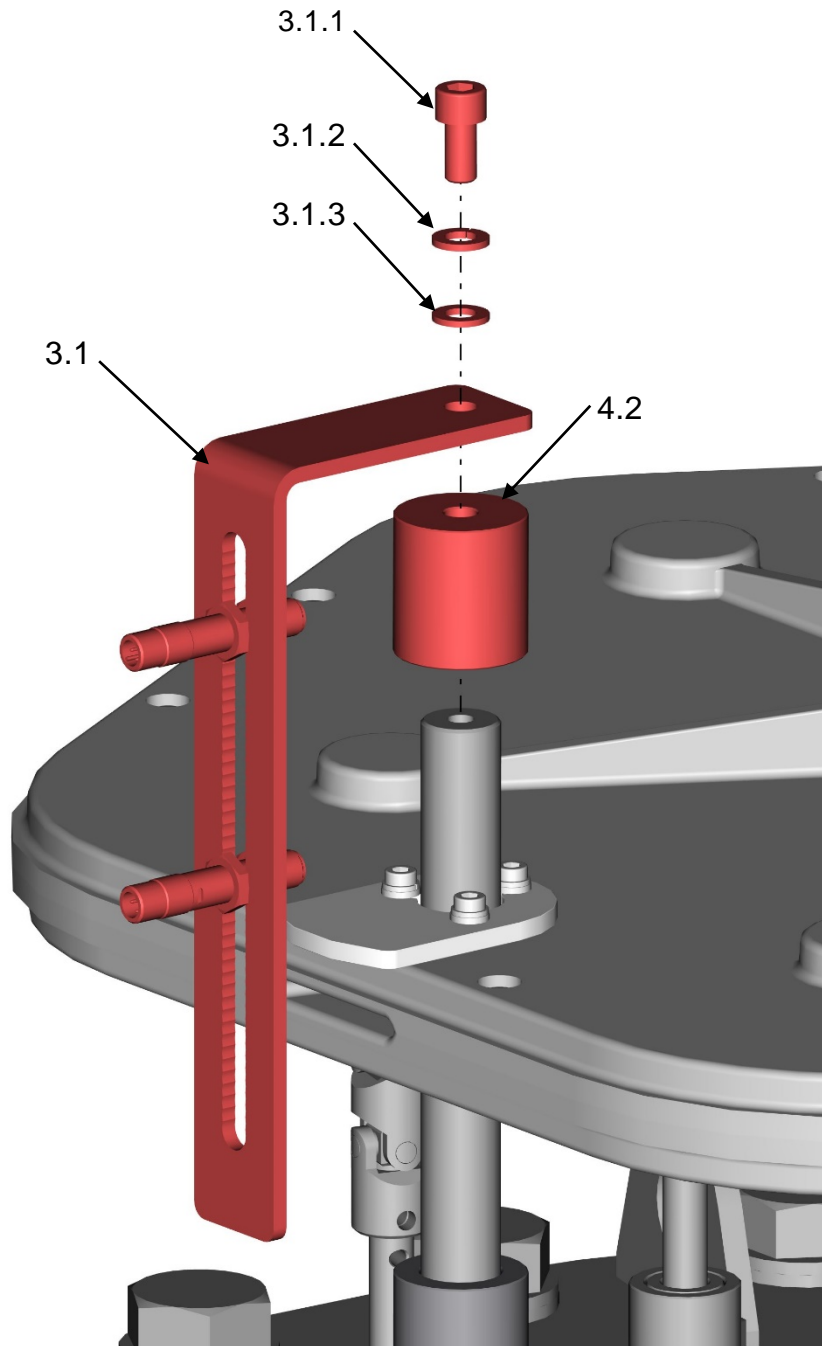

Figure 1 - Transmission Gear Cover Removal

9. Disassemble the Proximity Switch Assembly by removing its Screw's set (3.1.1)+(3.1.2)+(3.1.3)

- It is recommended to tighten back screw (3.1.1) in order to prevent stopper (4.2) from falling out.
- It is recommended to mark the position of the Proximity Switches (3.2) but no need to remove them from their Bracket (3.1).



*Figure 2 - Proximity Switch Removal*



10. Remove the Drive Unit Nut's sets (2.2.2)+(2.2.3)+(2.2.4).

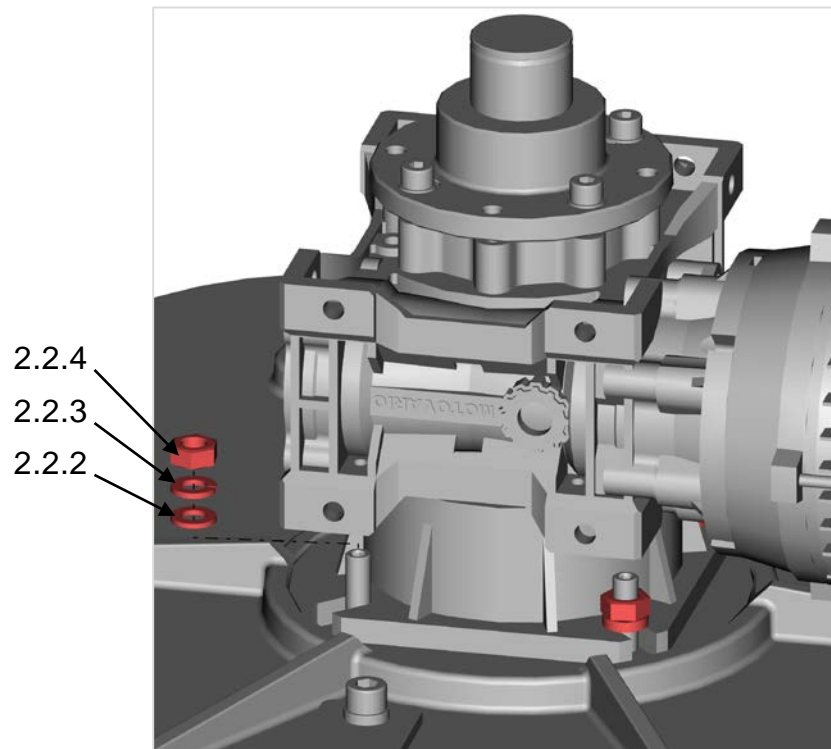

*Figure 3 - Drive Unit's Nuts Removal*

11. Remove Drive Unit from the Transmission Gear and Place it in a safe place aside the filter without disconnecting the cables.

12. Remove the Drive Shaft Key (2.3) from the Drive Shaft

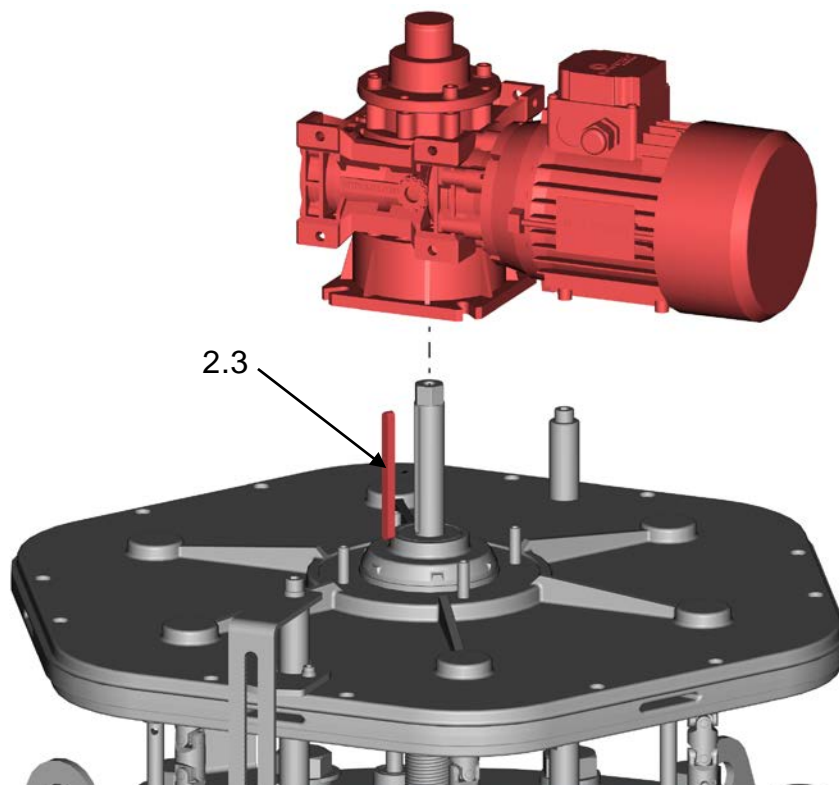

*Figure 4 - Drive Unit Removal*

13. Remove R-Clip (5.1.3) and Clevis Pins (5.1.1) from the Cardan Joints (5.1).

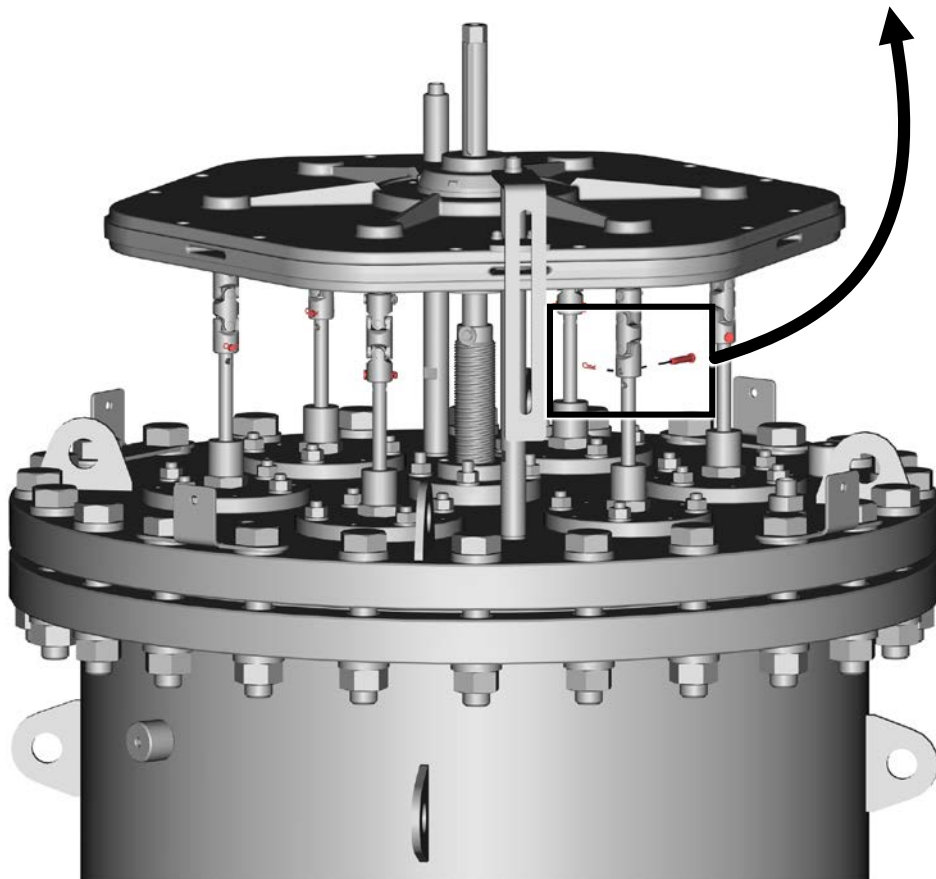
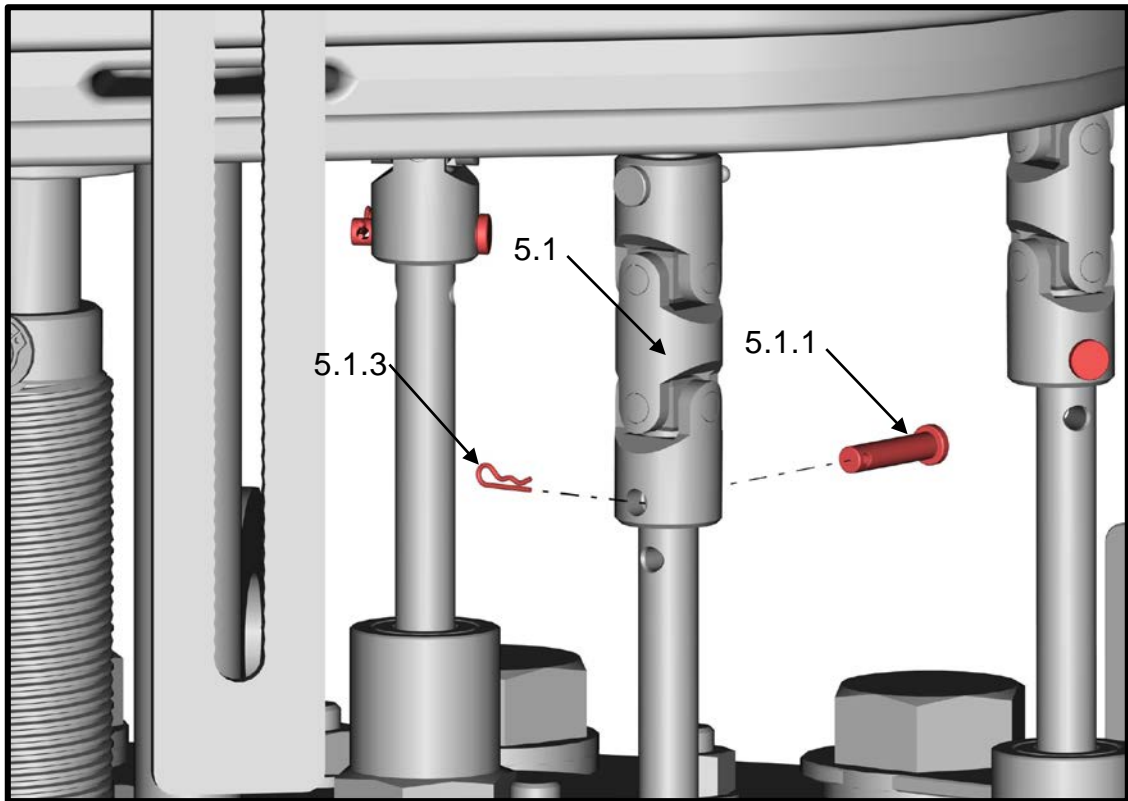

*Figure 5 - R-Clip, Clevis Pin Removal*

14. Disassemble Transmission Gear by removing its Nut's sets (6.2.1)+(6.2.2).

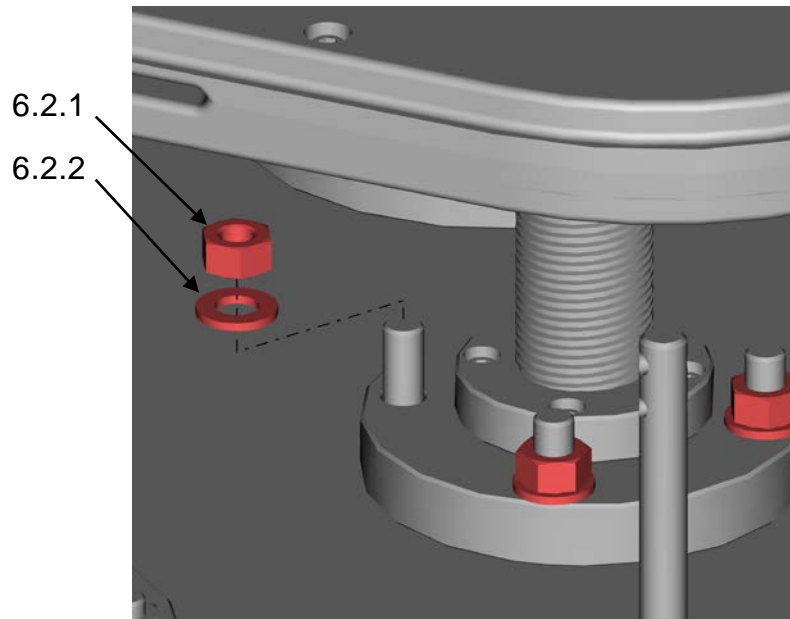

Figure 6 - Transmission Gear's Nuts Removal

15. Screw M10 Eye Bolt [TL-15] to the Drive Shaft and lift the Transmission Gear by means of Lifting Device [TL-19]. Place the Transmission Gear in a secure place.

16. Remove O-Ring (6.1).

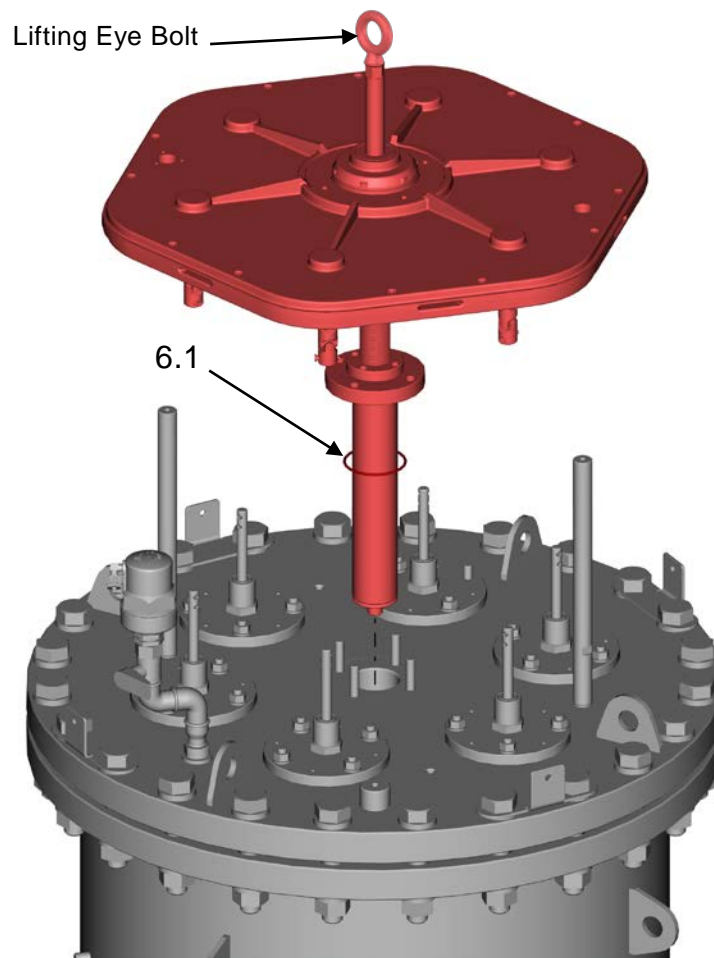

Figure 7 - Transmission Gear Removal

17. Remove Sealing Flanges Nut's sets (7.5.1)+(7.5.2).

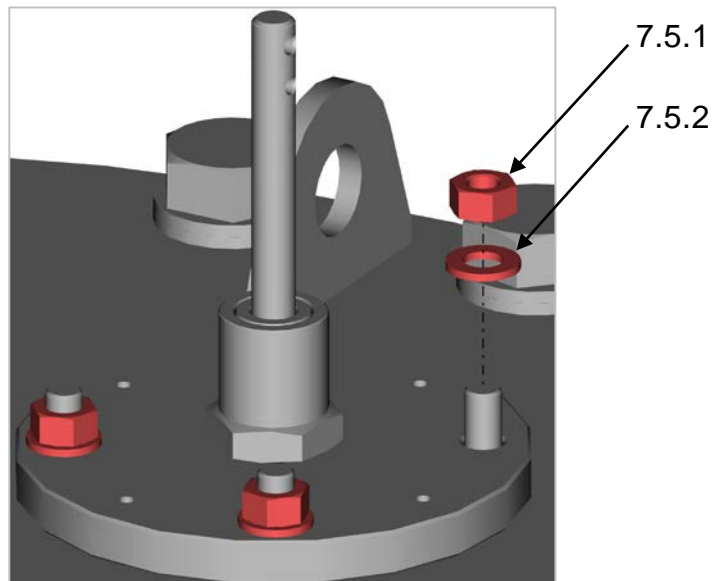

Figure 8 - Sealing Flange's Nuts Removal.

18. Pull out the Sealing Flanges over the Scanner Shafts.

---

**Note:** It is recommended to use Eye Bolt M8 and a metal Rod while lifting the Sealing Flanges, in order to avoid coating damaging.

---

19. Remove O-Ring (7.3) from Sealing Flanges.

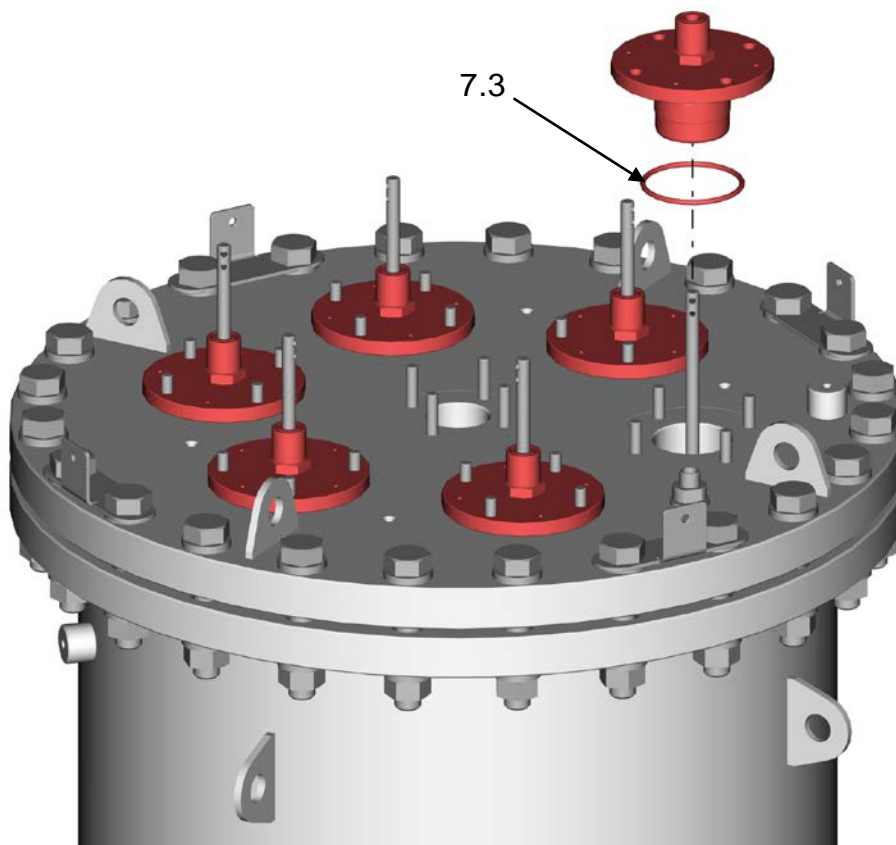

Figure 9 - Sealing Flange Removal

20. Loosen Lid Nuts (1.3) according to the procedure described at section I (Controlled Tightening/ Loosening of Lid nuts).
21. Make a clear mark on the Filter Lid, Upper Flange and brackets (1.5.2), so that it will be easy to bring them back to the same position.
22. Remove the Lid Bolt's sets (1.3)+(1.3.1)+(1.3.2)+(1.3.3) and place them aside.

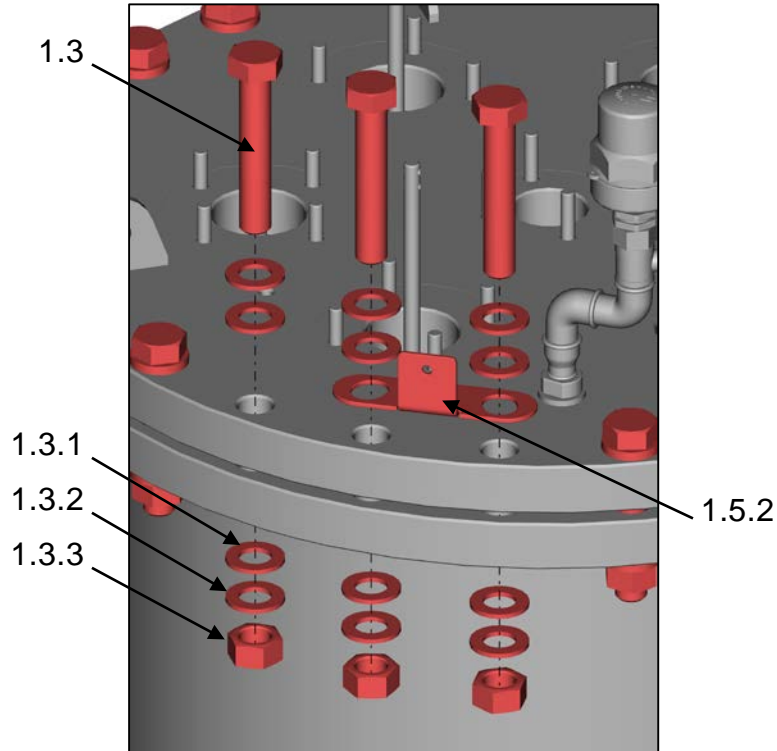

Figure 10 - Filter Lid Bolt's sets Removal

23. Attach Lifting Device [TL-19] to Lid.
24. Lift the Filter Lid upright above the Scanner Shafts and move it to the side.
25. Lower the lid and place it safely.
26. Remove the Lid Gasket (1.1).

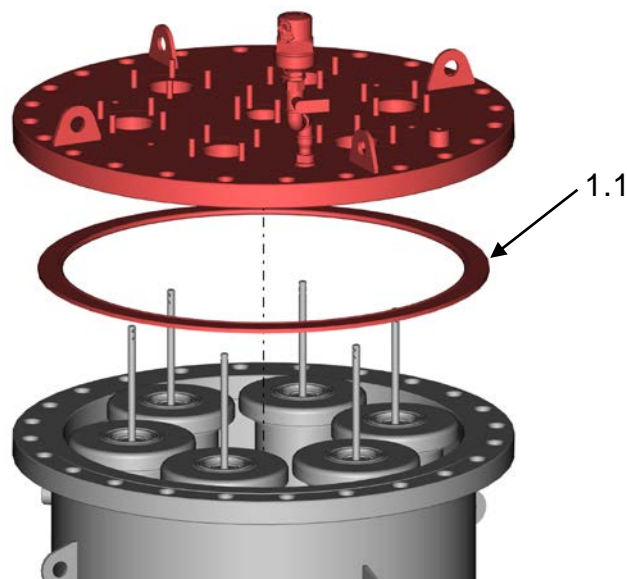
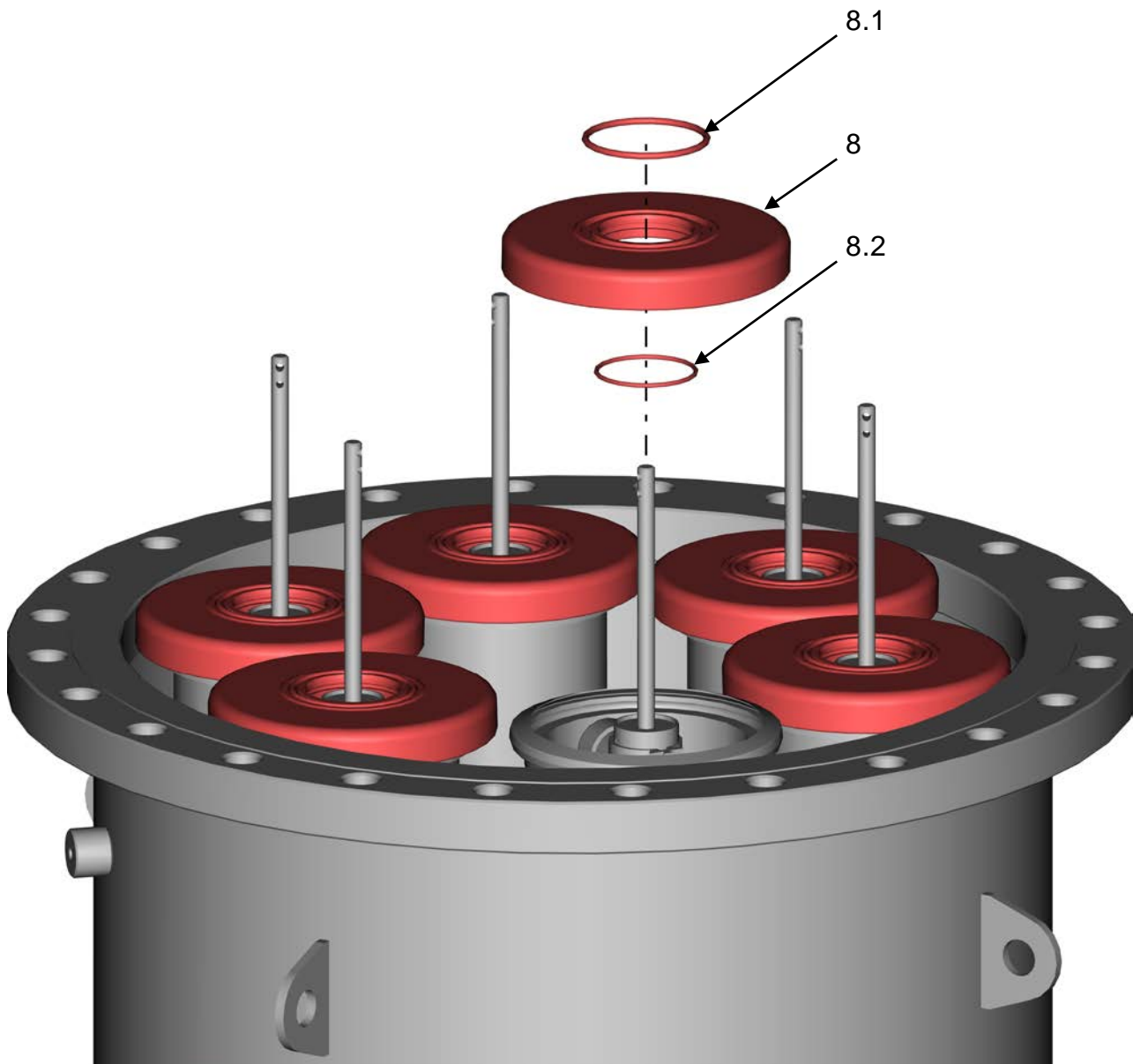

Figure 11 - Filter Lid Removal

27. Disassemble Upper clamps (8) with O-rings (8.1)+(8.2).



*Figure 12 - Upper Clamp Removal*

28. Pull up and remove the Suction Scanner Assemblies (9).



*Figure 13 - Suction Scanner Removal*

29. Carefully pull out the Screens (10), be careful not to damage them.

30. Remove both Seals (10.1) from the Screens.

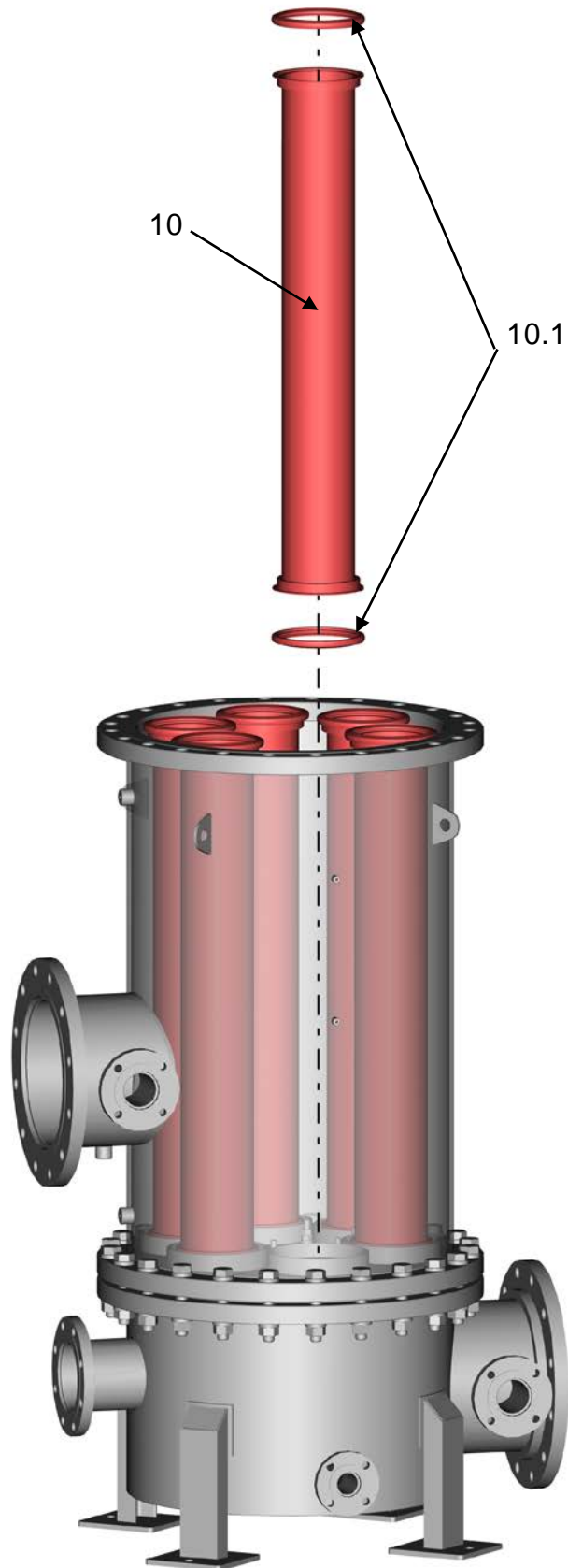

Figure 14 - Screen Removal



## g. Replacing shaft sealing set

### Replacing Screens Seals and O-rings

1. Replace O-rings (8.1)+(8.2).
2. Replace Screen seals (10.1)
3. Apply ML-2 on the O-Rings and ML-4 on the Screen seals.

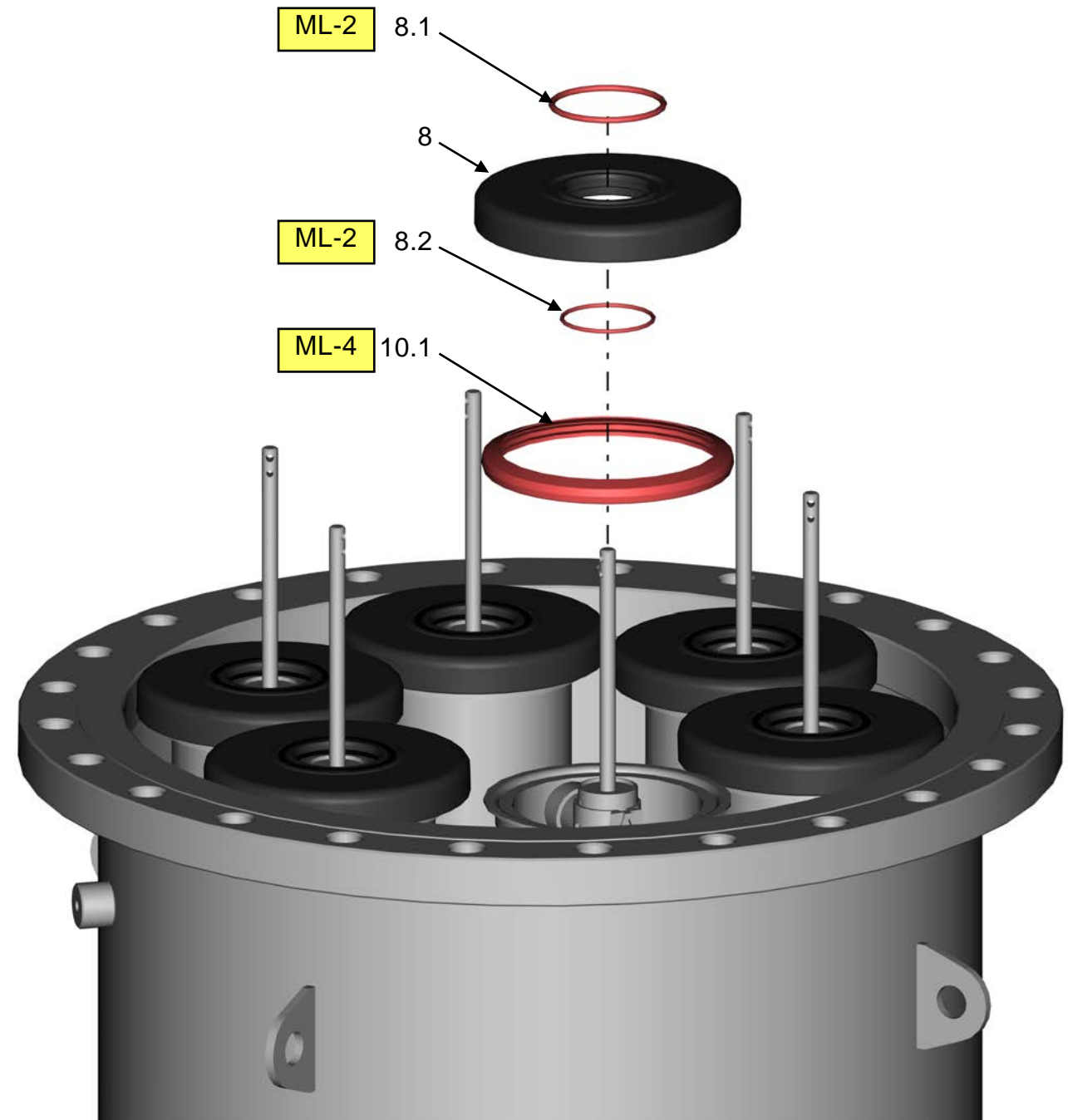

Figure 15 - Upper Clamp Assembly

Replacing Seals and O-rings of the Scanner's Sealing arrangement:

1. Unscrew Sealing Nut (7.7).
2. Remove and replace O-Ring (7.10) by means of Seal Extractor (TL-16).
3. Replace O-Rings (7.8) and the Wiper Seal (7.9). Make sure the open side of the seal is facing toward the Sealing Flange's bore (7.1).
4. Replace O-rings (7.3)+(7.4).
5. Apply ML-2 on the all new O-Rings.

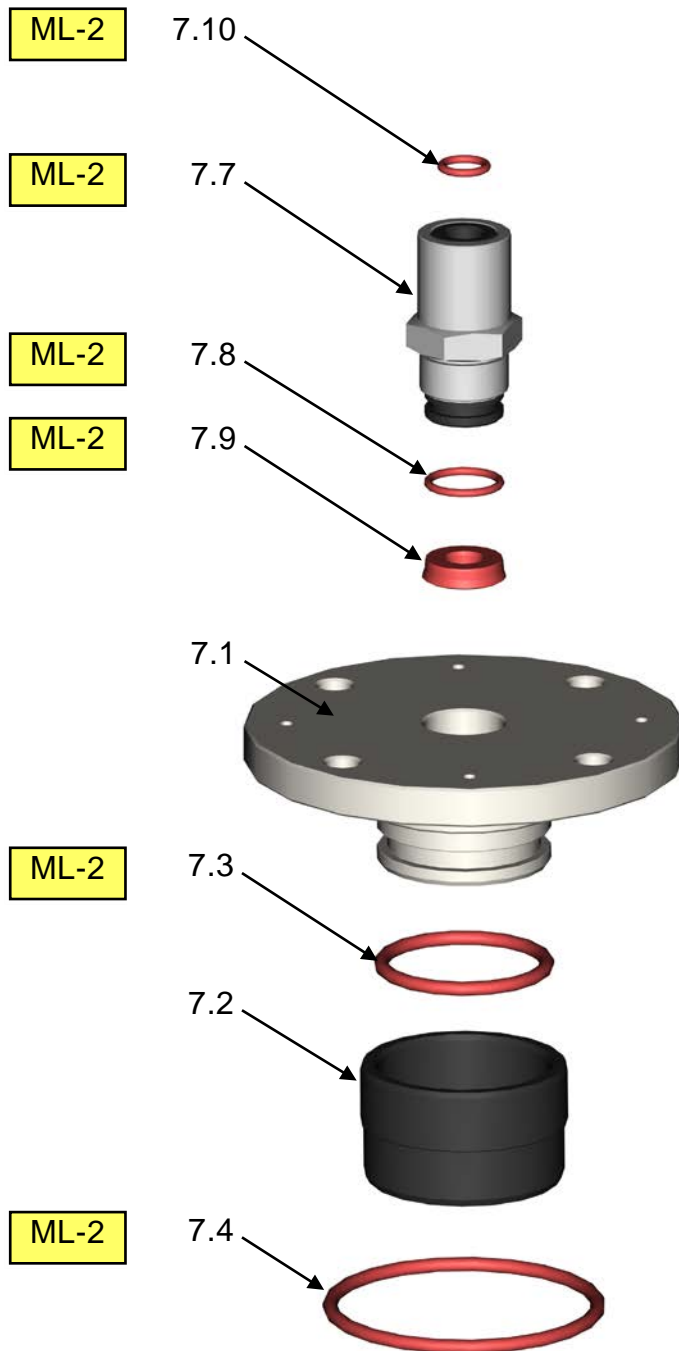

Figure 16 - Sealing Flange Assembly

## h. SLN Scanner – inspection and maintenance

### Replacing Scanner Shafts:

1. Replacement of Scanner's Shaft is required only in case the existing shaft is worn or scratched.
2. Unscrew plastic plug (9.1.2) and pull out pin (9.1.1).
3. Replace the Shaft (9.1) and connect it by re-placing the pin and the plug.

### Suction Scanner - Inspection and Maintenance:

The following instructions determine the criteria for SLN replacement. However, in Thorough Maintenance after one year of operation it is highly recommended to replace the SLN sets regardless of their mechanical condition. Tighten the SLN Nut (9.2.10) by means of a suitable wrench.

1. Visually inspect for clogged Nozzles.
2. Push the Nozzle inward; verify smooth sliding in both directions.
3. Measure the distance of the Nozzle surface from the Nut edge. A Nozzle should be replaced if  $A \leq 9.0$  mm. It is recommended to replace all the Nozzles in the Scanner if more than 4 Nozzles along the Scanner are too short.

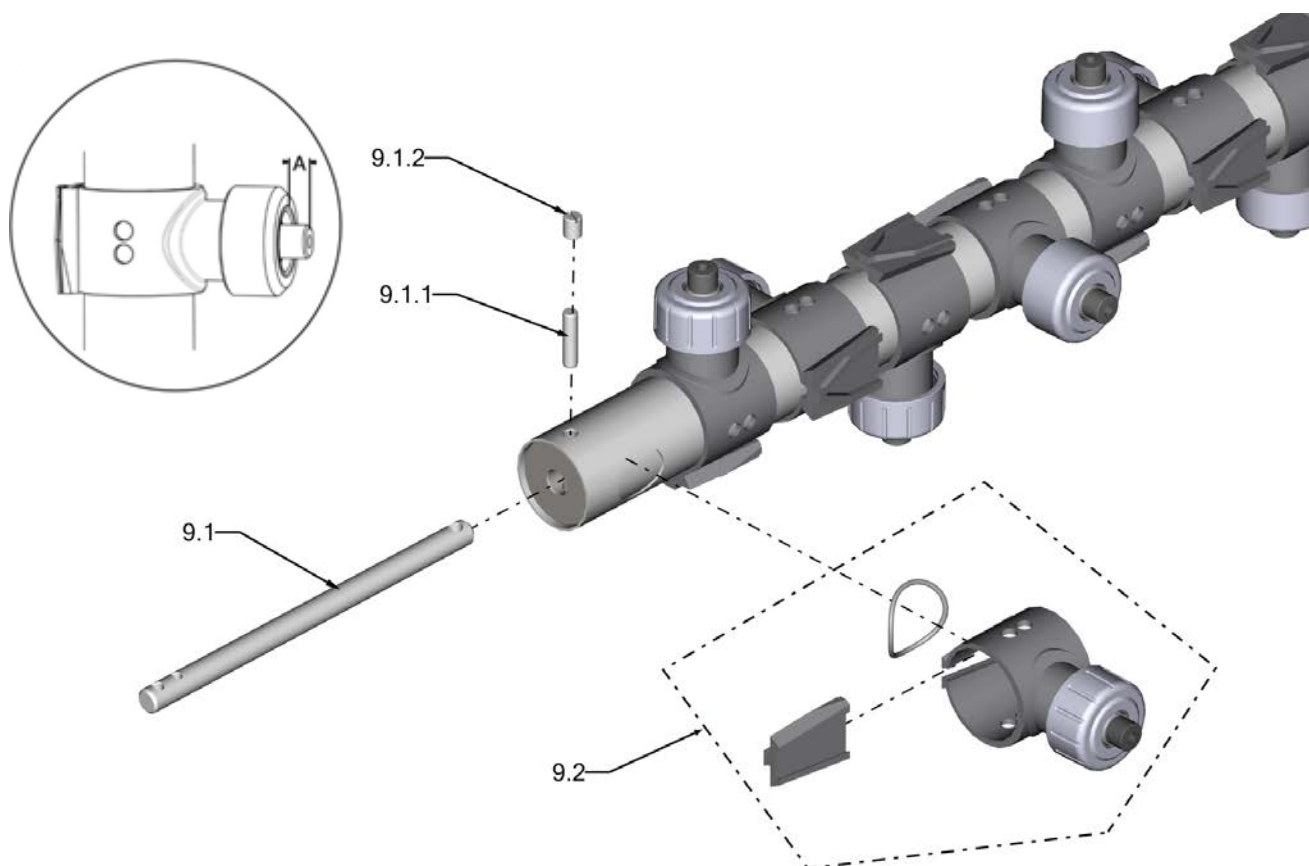

Figure 17 - Suction Scanner Maintenance

4. In case of non-smooth movement or too much movement:  
unscrew the SLN Nut (9.2.10), pull out the internals and replace with new parts:  
(9.2.4)+(9.2.5 x2)+(9.2.6)+(9.2.8)+(9.2.9). Usually, there is no need to replace the spring (9.2.7).
5. Re-tighten the SLN Nut (9.2.10) by hand.

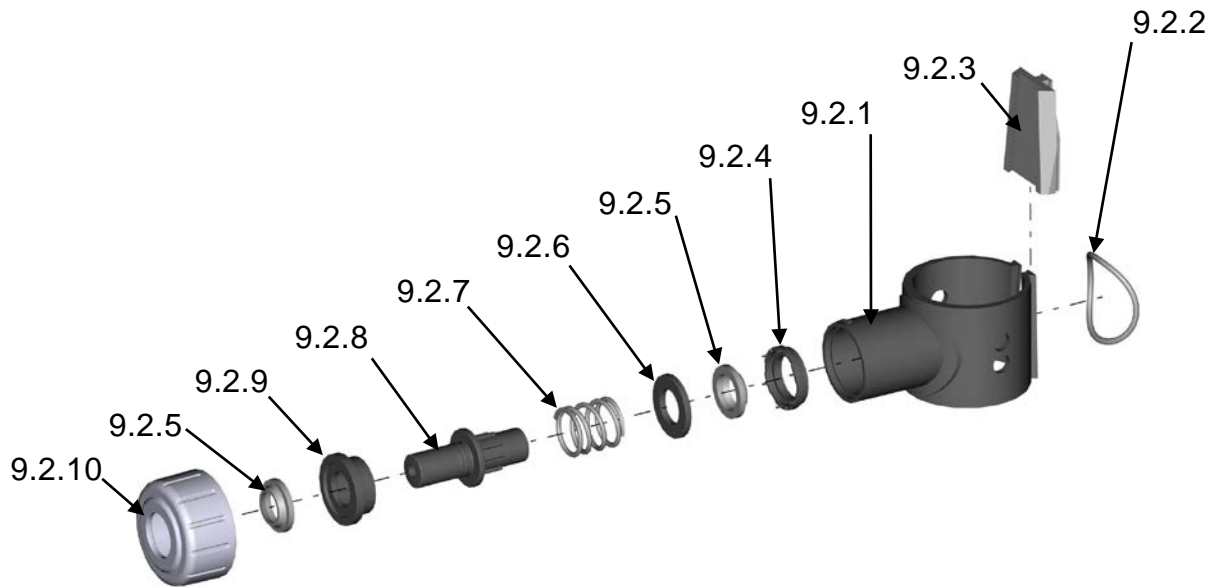

Figure 18 - Suction Scanner Internals Replacement

### i. Reassembling filter components

1. Clean and inspect all internal parts before re-assembling the filter.
2. Verify that parts (11)+(11.1)+(11.2) are property located.

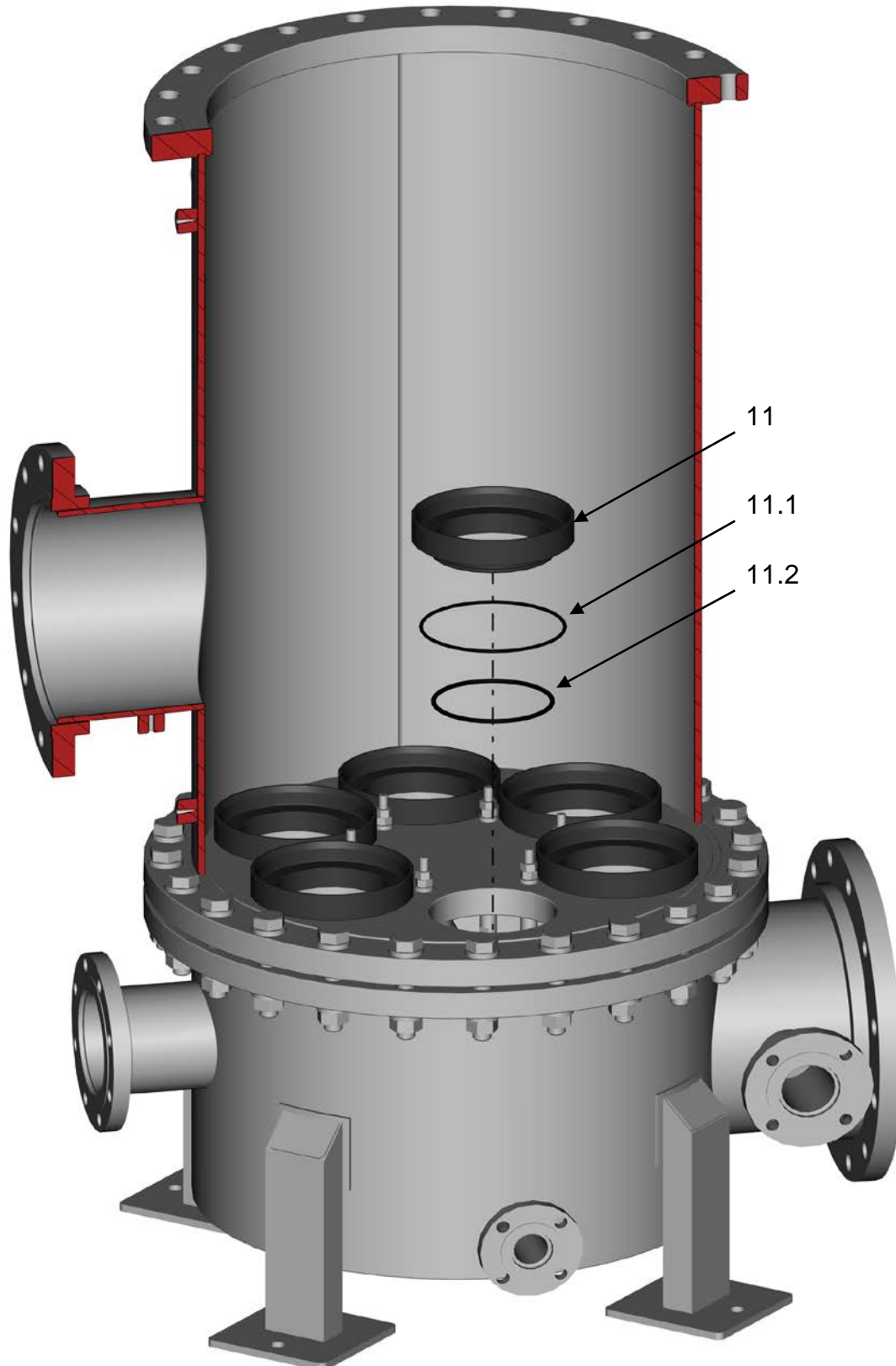

Figure 19 – Lower Clamps location

3. Apply ML-4 on both Screen Seals (10.1).
4. Place Screen Seals on Screen (10) edges.
5. Insert Screen into its Clamp in the Flushing Chamber.

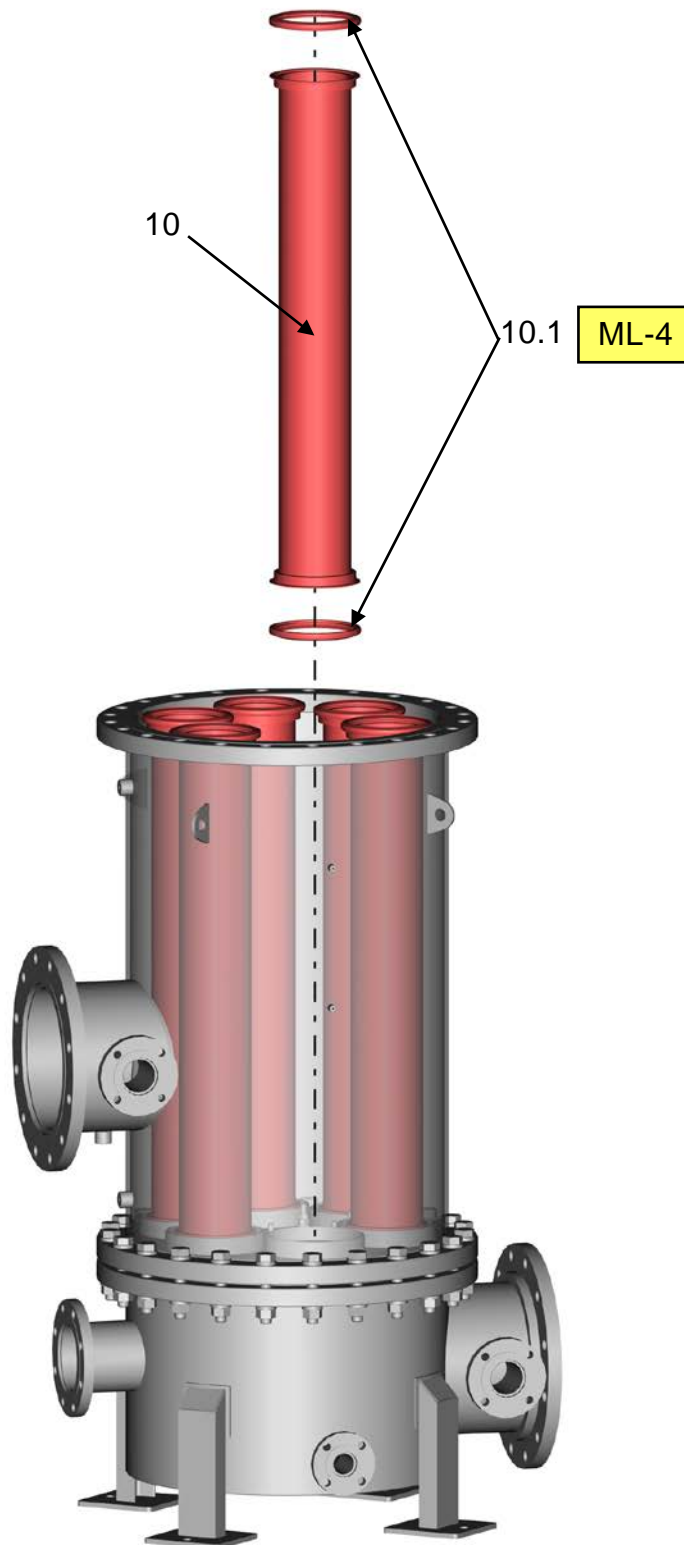

Figure 20 - Screen Assembly

6. Insert Suction Scanner Assembly (9) into its place.



*Figure 21 - Suction Scanner Assembly*

7. Place the Upper Clamp (8) on top of the Screen, make sure Seals (8.1)+(8.2) are at their place.

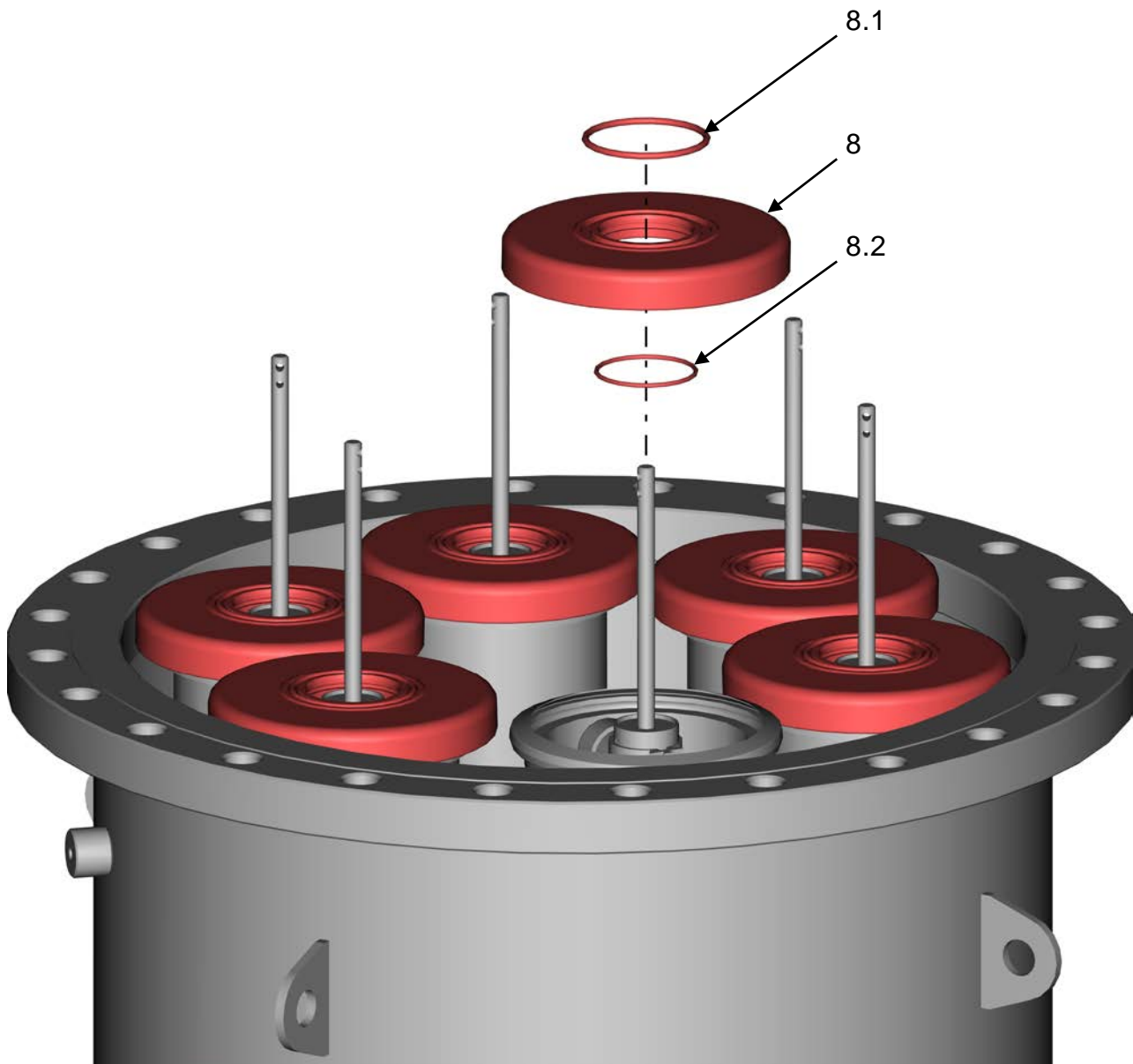

*Figure 22 - Upper Clamp Assembly*



8. Place the Lid Gasket (1.1) on the Upper Housing Flange.
9. Attach Lifting Device [TL-19] to Lid.
10. Lift the filter Lid and bring it above the filter Housing. Turn the Lid until the marks are aligned. Slowly lower the Lid straight and leveled.
11. The Scanner Shafts should go through the openings and all the Upper Clamps must be positioned properly in the Lid holes.

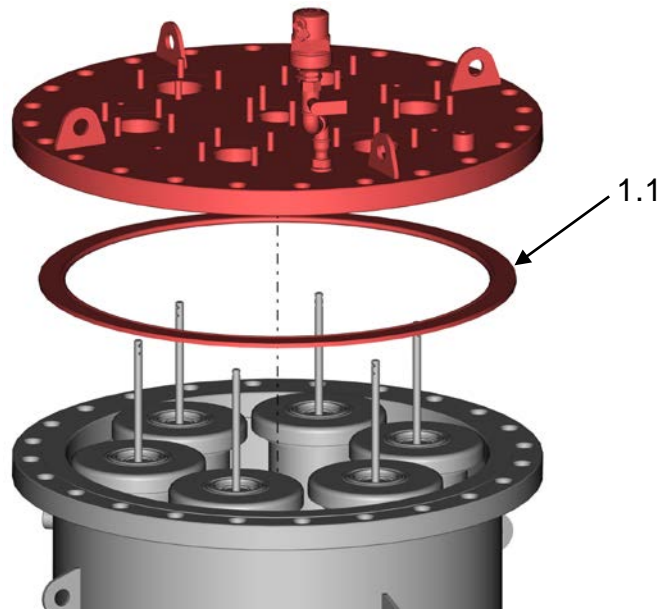

Figure 23 - Filter Lid Assembly

12. Screw Lid to Housing using 4 bolt's sets (1.3)+(1.3.1)+(1.3.2)+(1.3.3) in a cross pattern. **Do not tighten them firmly yet.**

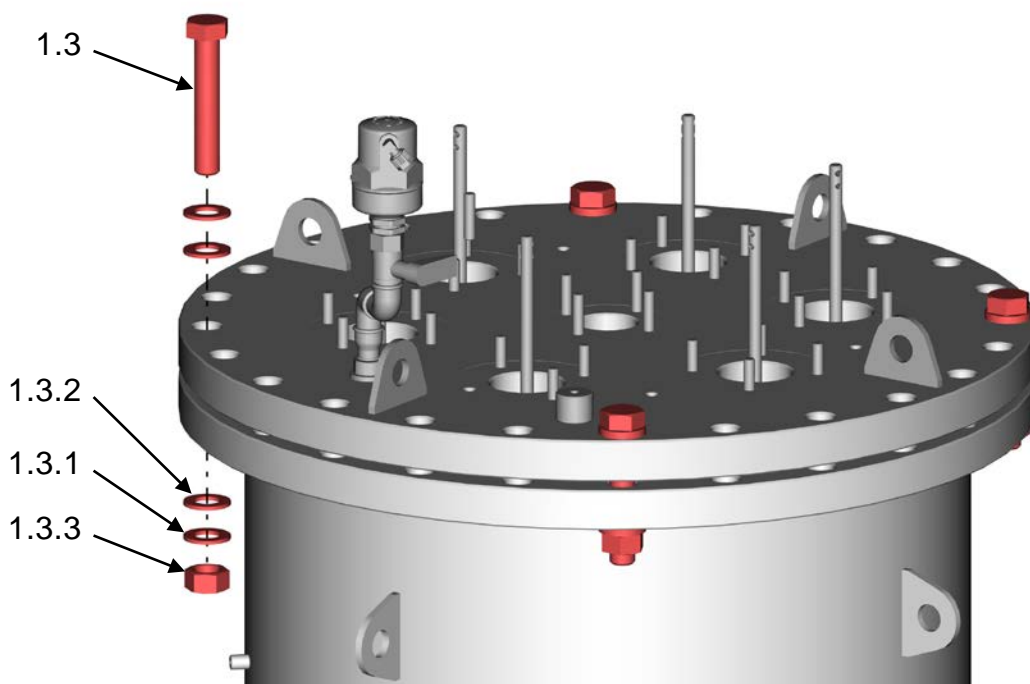
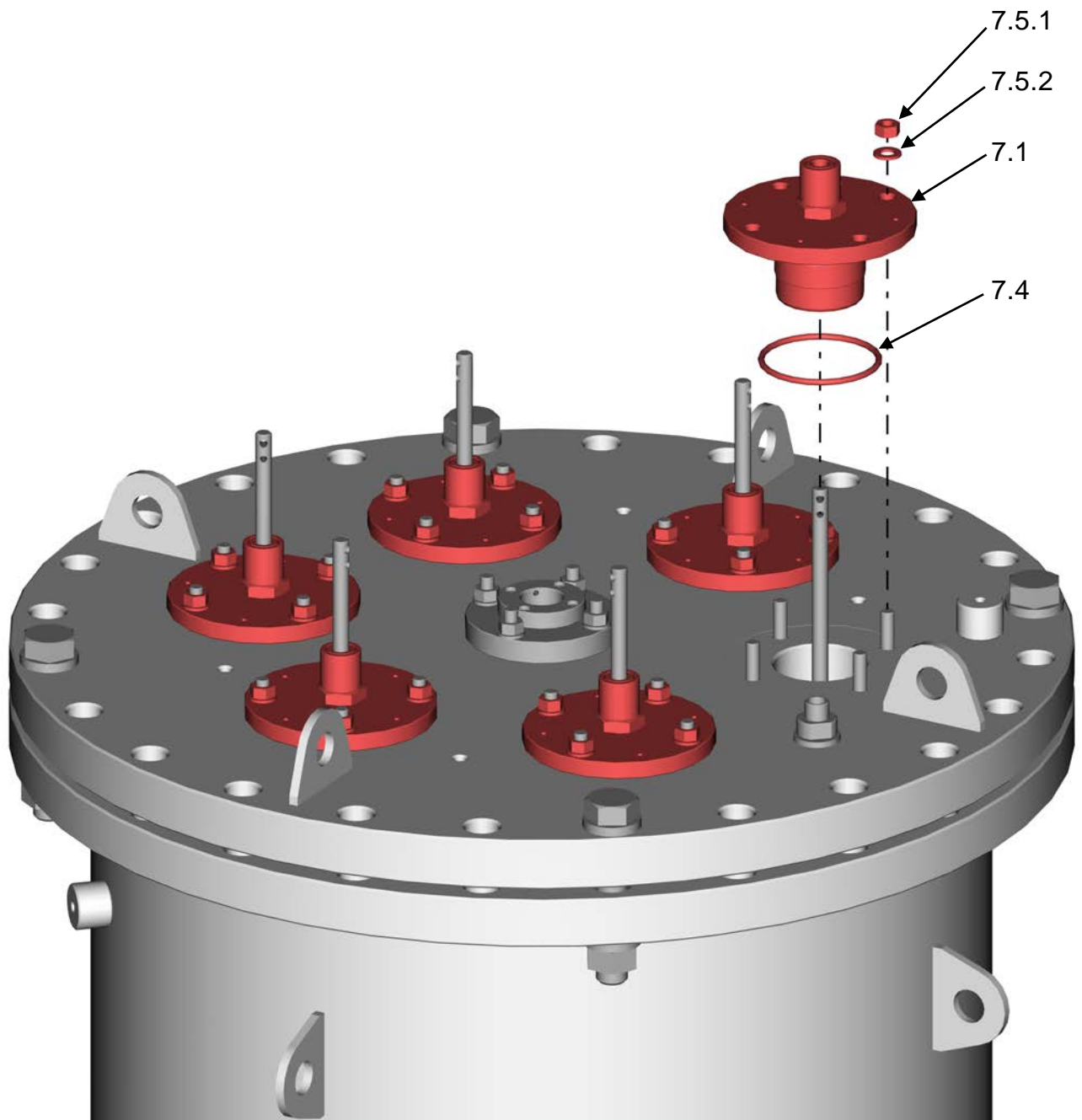

Figure 24 - Filter Lid Assembly - continue

13. Insert O-ring (7.4) into Sealing Flange (7.1).
14. Insert Sealing Flange into Lid, make sure that the Scanner Shafts are not pushed into the filter.
15. Tighten using Sealing Flange Nut's set (7.5.1)+(7.5.2).



*Figure 25 - Sealing Flange Assembly*

16. Apply ML-2 on O-Ring (6.1) and insert it into Threaded Shaft Housing (6).
17. Attach Lifting Device [TL-19] to the Transmission Gear Eye Bolt.
18. Lower the Transmission Gear to its place carefully. Verify that all Scanner Shafts are in their Cardan Joints.
19. Remove M10 Eye Bolt [TL-15] from the Drive Shaft.

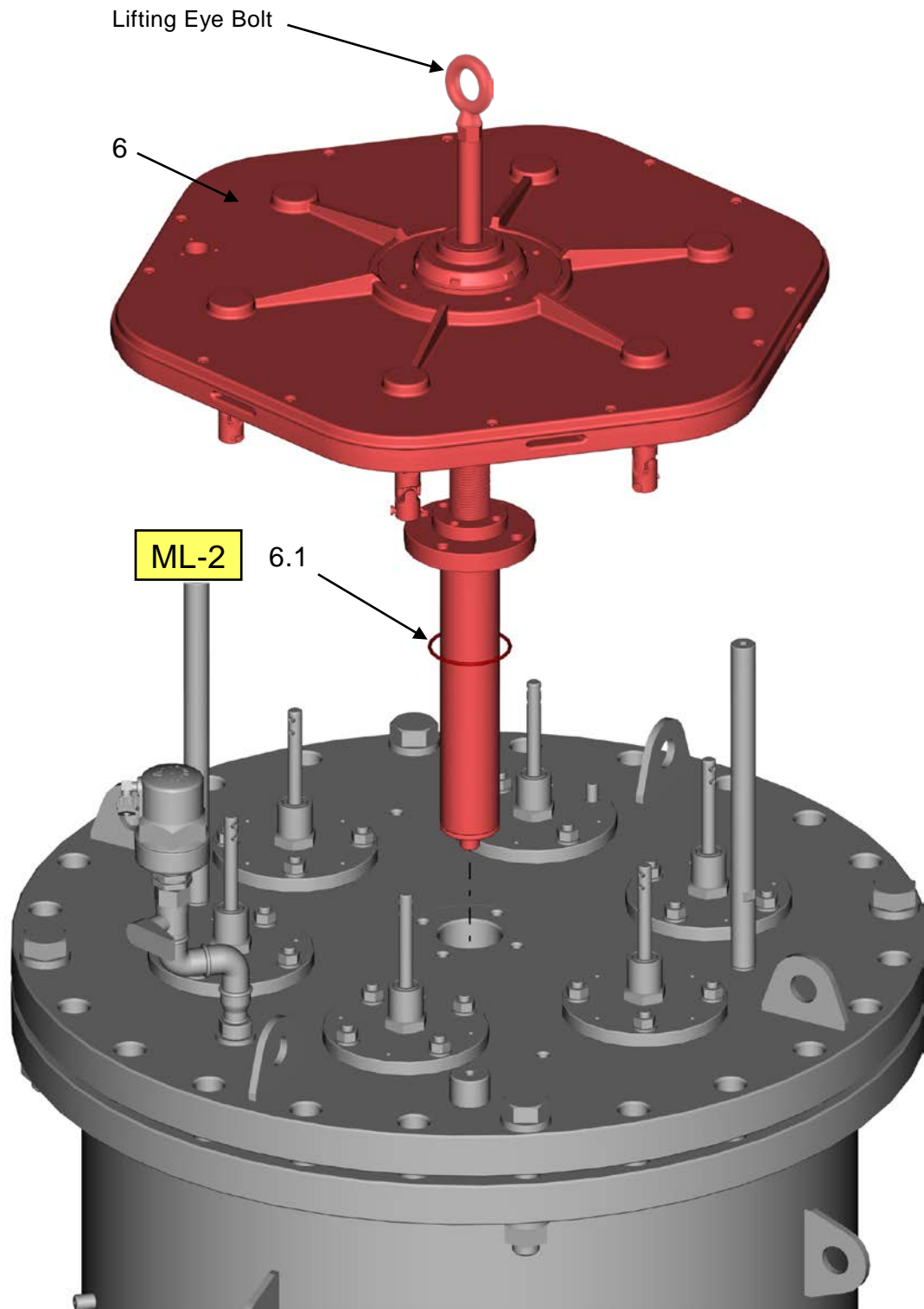

Figure 26 - Transmission Gear Assembly

20. Assemble Scanner Shafts to the Cardan Joints (5.1) using Clevis Pins (5.1.1) and R-clips (5.1.3).

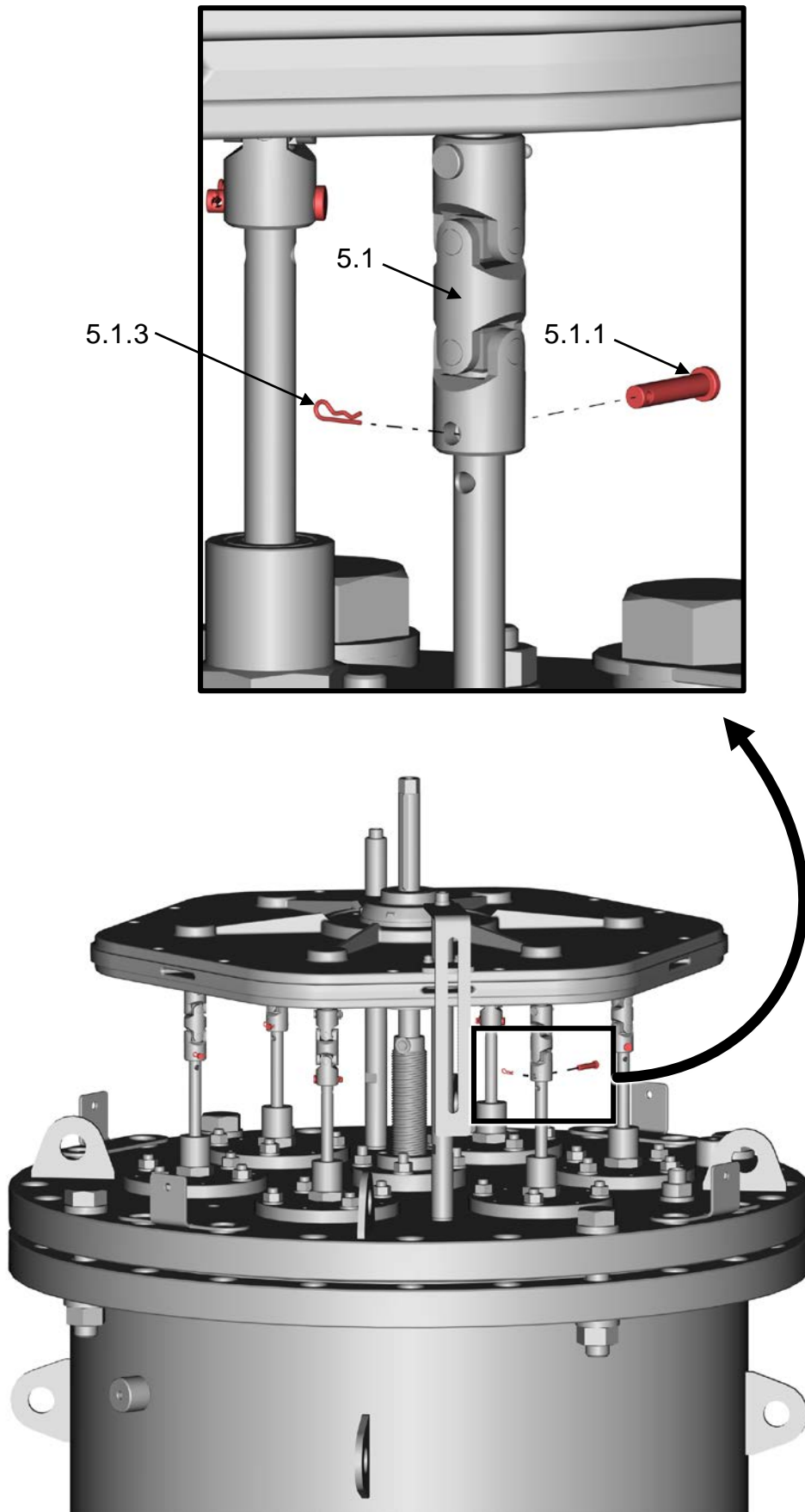
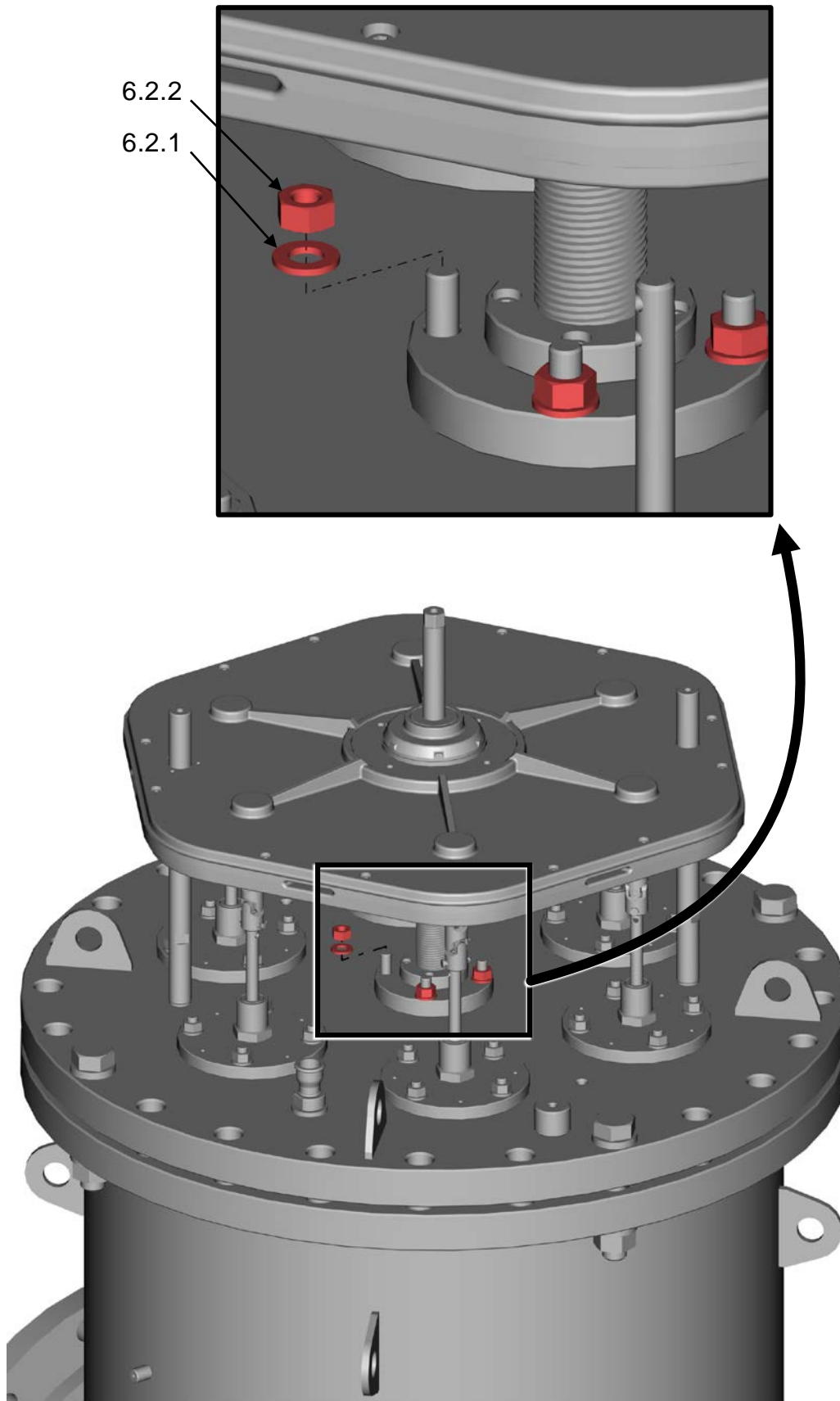

Figure 27 - R-Clip, Clevis Pin Assembly

21. Tighten Transmission Gear Nut's set (6.2.1)+(6.2.2).



*Figure 28 - Transmission Gear Nuts Assembly*

22. Assemble the Drive Shaft Key (2.3) to the Drive Shaft. Apply Grease ML-3 on the shaft and Key.

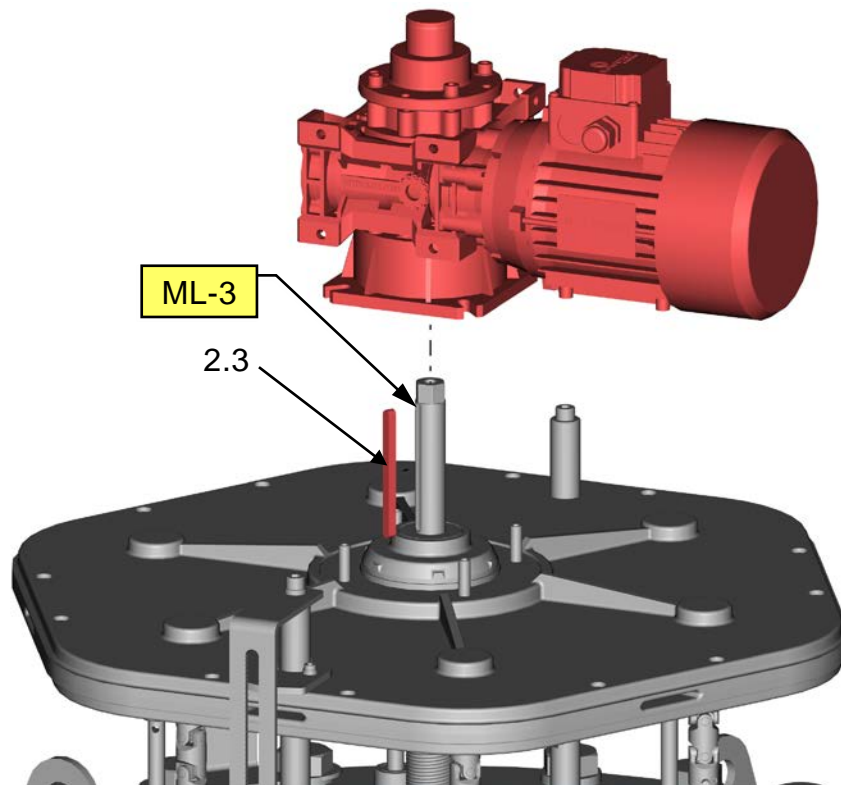
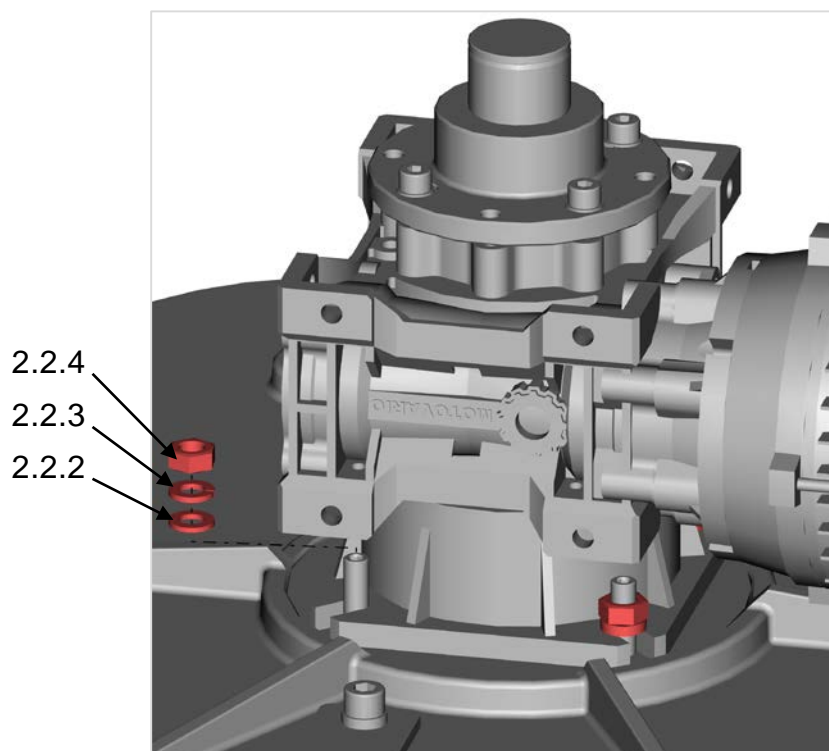

Figure 29 - Drive Unit Assembly

23. Assemble the Drive Unit to the Transmission Gear using Nut's set (2.2.2)+(2.2.3)+(2.2.4).

**Warning:** Check and verify proper connection of the cables and cable glands to the motors.



24. Re-install the Proximity Switch Assembly to its place using its Screw's set (3.1.1)+(3.1.2)+(3.1.3), do not forget to return Stopper (4.2)

*Note: If the switches are not in position follow instruction on section j (Proximity switches adjustment).*

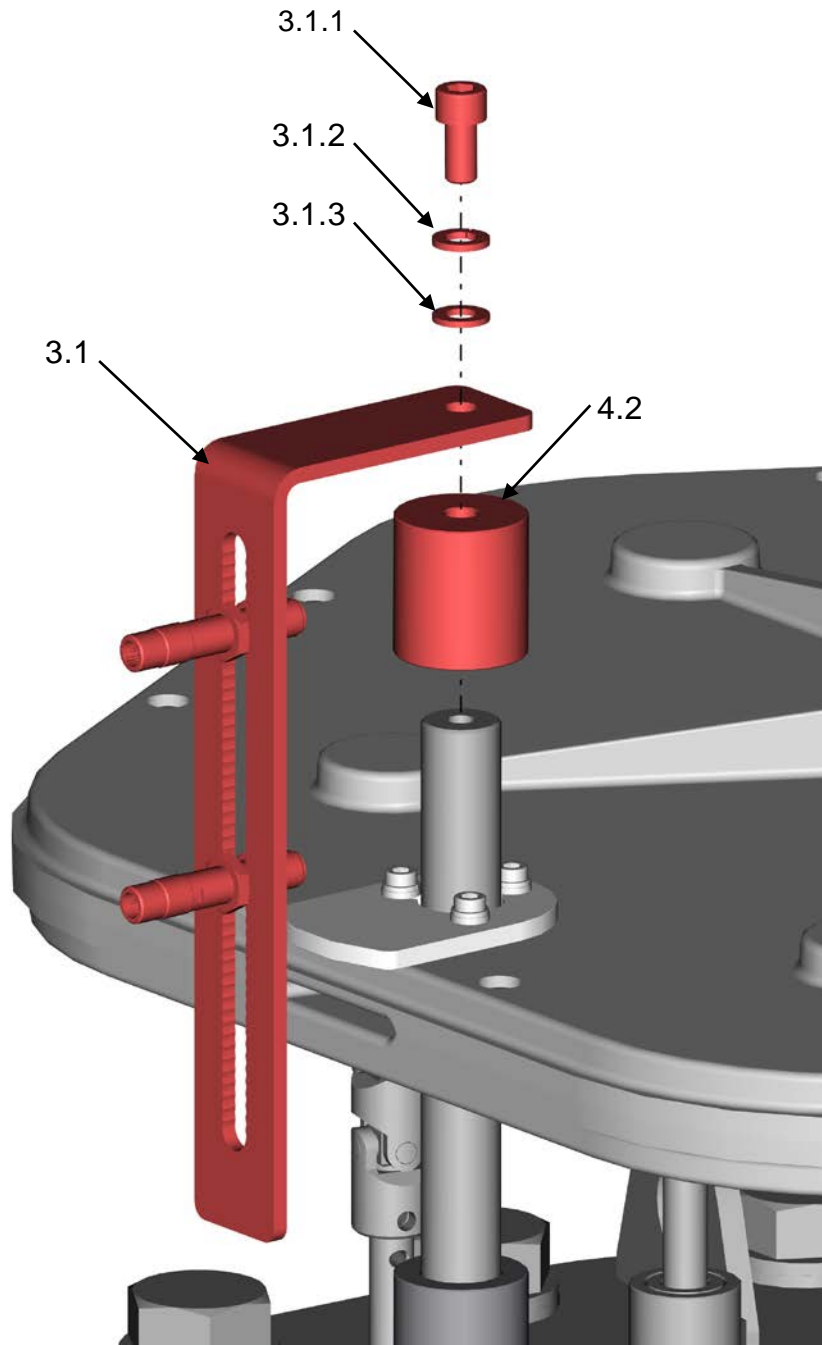

Figure 30 - Proximity Switch Assembly

25. Assemble Brackets (1.5.1) according to marks.
26. Assemble and Tighten Lid Bolt's sets (1.3)+(1.3.1)+(1.3.2)+(1.3.3) according to the procedure described at section I (Controlled Tightening/ Loosening of Lid nuts).
27. Re-arrange all cables with new cables ties.

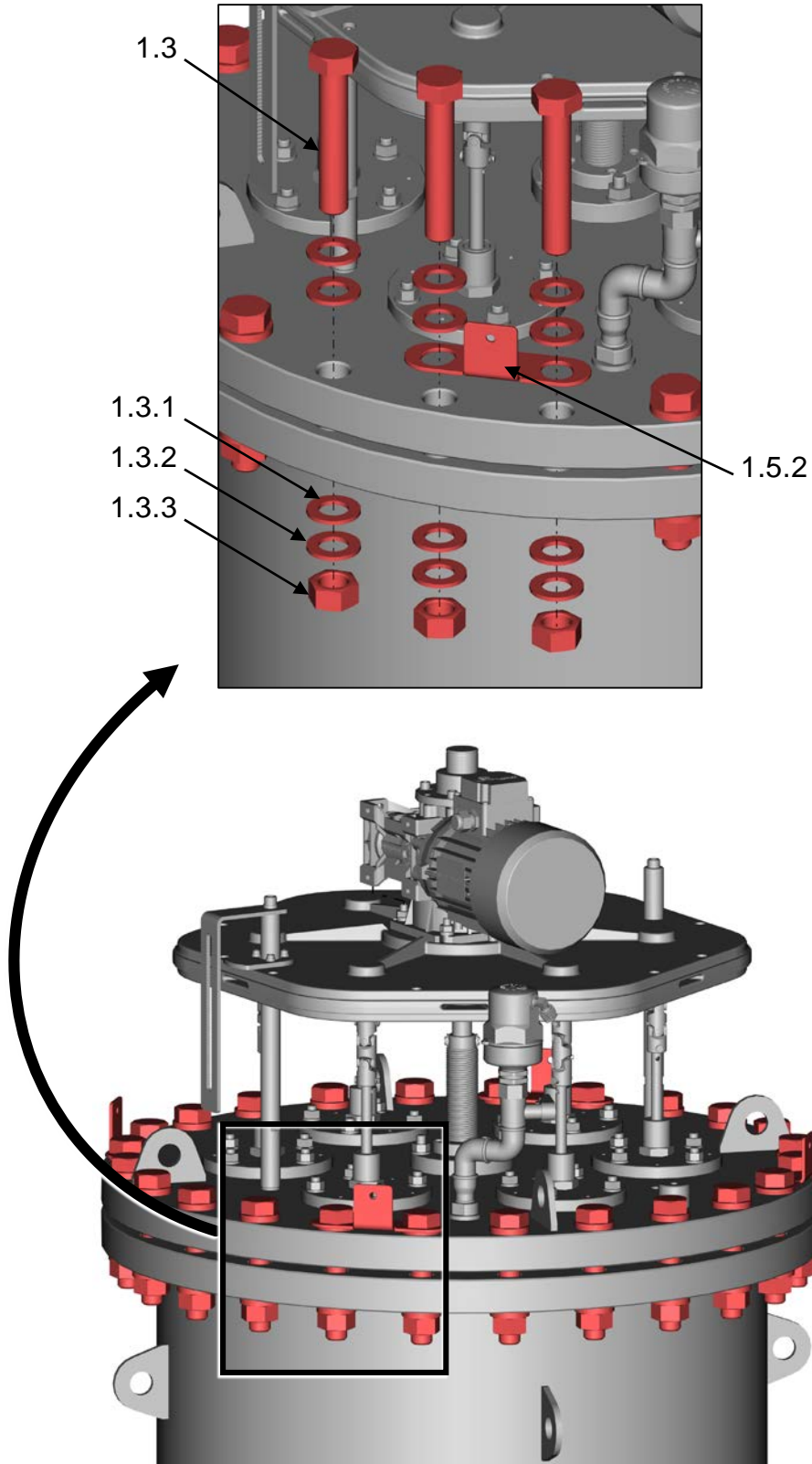
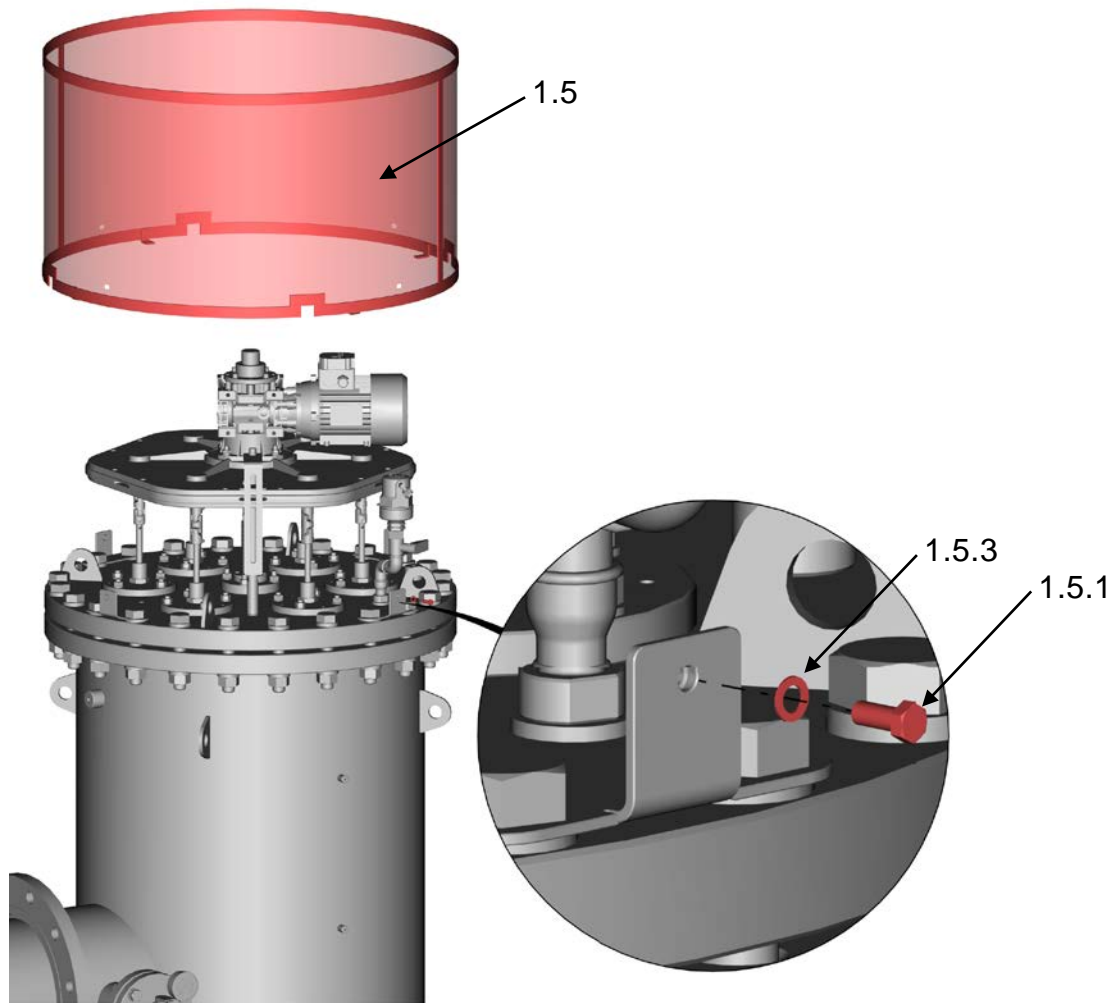

Figure 31 - Cable Trays Assembly



28. Assemble Transmission Gear Cover (1.5) using its Bolt's set (1.5.2)+(1.5.3).



*Figure 32 - Transmission Gear Cover Assembly*

29. Connect power supply to the filter and open the relevant switches.

30. Open Inlet and Outlet Valves.

31. Close Drain Valve and Flushing Valves.

## j. Proximity switches adjustment

The following description is related to Amiad Standard Proximity Switches. Different types of Proximity Switches may have different features but should work with the same principals.

*Note: The proximity switch is NC (Normally Closed) conductive and illuminating as long as it is far from the Activating Plate.*

1. Rotate Drive Shaft counterclockwise (moving up) until it stops. Then rotate half-of-a-turn back.
2. Place the Upper switch in the highest hole of the Proximity Switch Bracket that DOES NOT illuminate. This is the upper position in which the switch should be locked.
3. Lock the switch by means of two 17mm wrenches. Verify once again gap of 2 mm. Use Loctite 243 to lock the Nuts.
4. Move transmission gear a few turns downward, then raise it again until switch is de-actuated (stop illuminating).
5. Measure the height from the Cardan Joint lower surface (5.1) to the surface of the nearest Sealing Bushing (H). [H minus 71mm] should be the height of the Cardan Joint when at the lower position (h). See example below.
6. Rotate the Drive Shaft clockwise (moving down) until height is equal to the calculated "h".
7. Place the Lower switch in the lowest hole of the Proximity Switch Bracket that DOES NOT illuminate. This is the lower position in which the switch should be locked.
8. Lock the switch by means of two 17mm wrenches. Verify once again a gap of 2 mm. Use Loctite 243.
9. Move transmission gear a few turns upward and then lower it again until switch is de-actuated (stop illuminating).
10. Insert the Key (2.3) into the Drive Shaft Keyway and apply some grease.
11. Slide Drive Unit along Drive Shaft. Connect Drive Unit to red transmission.
12. When ready and safe, activate the Motor in both directions and verify correct functioning.

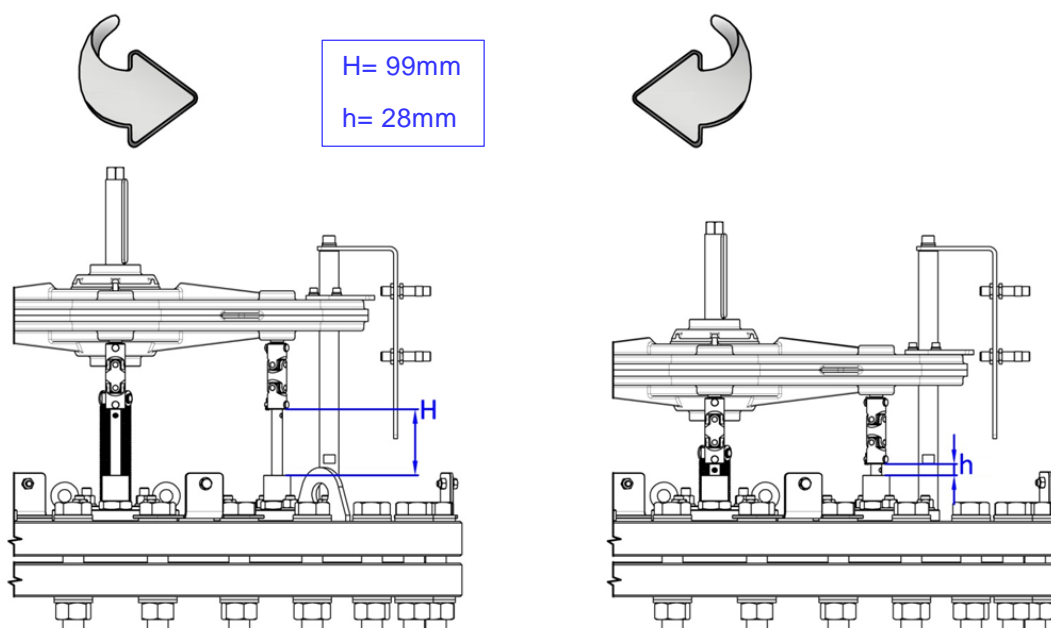

Figure 33 - Proximity Switch Adjustment

## k. Controlled Tightening/ Loosening of Lid nuts

### Tightening

The nuts of all bolts shall be installed finger tight, followed by gradually increasing the bolt force to the required value in minimum 4 passes as described in Table 3. The bolt sequence shall be in accordance with the given bolt sequence chart on Figure 34.

The first pass may be done with a hand-spanner, without torque control.

pass 1	pass 2	pass 3	pass 4	pass 5
30%	60%	100%	100%	100%
140	270	440	440	440

Table 3 - Bolting up torque in Nm

Pass 4 shall be in circumferential pattern and be repeated until the nuts do not move;

Pass 5 (optional) time permitting, wait minimum of 4 hrs and repeat Pass 4; this will restore short term relaxation at ambient conditions.

### Loosening

To prevent over yielding of the bolts during dismantling, loosening of the individual bolts shall be done in a minimum of two passes (50%, 0%) following the given bolt sequence.

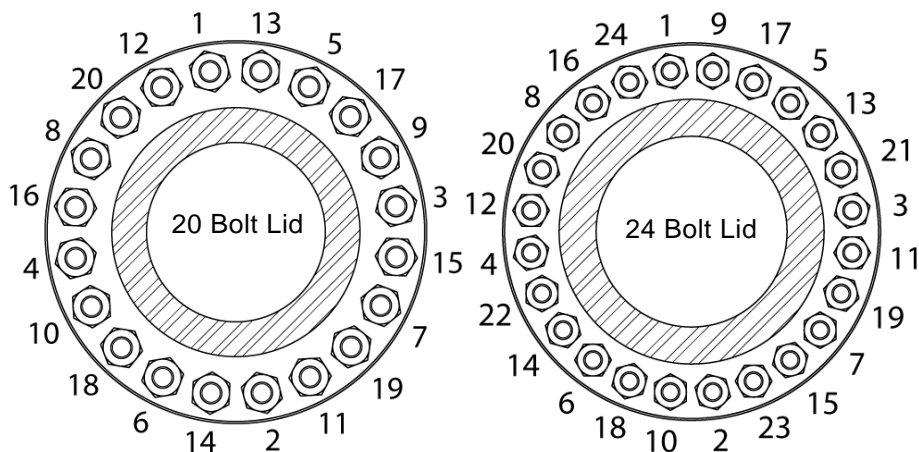

Figure 34 – bolt sequence chart

## I. BOLTS TIGHTENING:

All bolts, unless otherwise specified, should be tightened according to the following Torques Table:

TORQUE TABLE		
Bolt Size	N-M	Lbs-ft
M6 / 1/4"	8	6
M8 / 5/16"	20	15
M10 / 3/8"	40	30
M12 / 1/2"	81	60
M16 / 5/8"	176	130
M20 / 3/4"	340	250
M24 / 1"	680	500
M27	880	650
1-1/2"	1370	1012

### m. FLANGE TIGHTENING PROCEDURE:

All flanges in the filter are sealed by O-Rings or GS-ST P/S Gaskets. Therefore it is essential that load is to be applied gradually and evenly across the Flange to insure even-down and uniform compression of the Gasket.

Establish a star pattern or cross bolting pattern that will alternate sides of the Flange as load is applied.

Follow the sequence of numbers according to the relevant pattern.

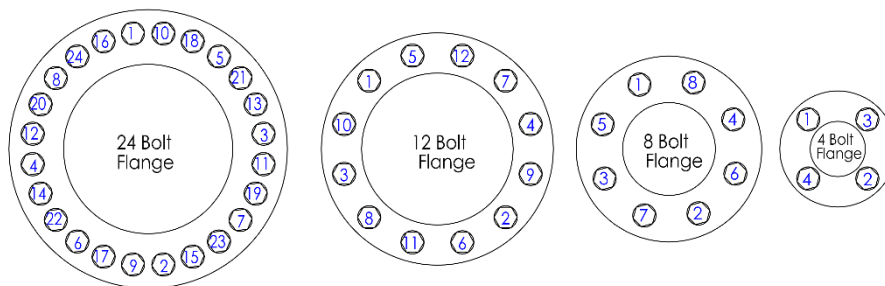

### n. Restarting the filter

1. Double check and verify tightness of all bolts.
2. Clean the working area and remove any unused parts and tools from the Filter Lid.
3. Re-Connect the power and run a "dry flush cycle". Verify opening of the Flushing Valves and proper motion of the Transmission Gear and Suction Scanners.
4. Close the Drain Valve and open the Inlet Valve to fill the filter with water.
5. Run a few flush cycles while Outlet Valve is still closed.
6. Check and take care of any leaking.
7. Gradually open the Outlet Valve. The filter is now back in operation.

## 12. Troubleshooting

## Troubleshooting

Malfunction	Possible Cause	Corrective Action
High DP + Continuous Flushing	Extreme load of suspended solids.	<ol style="list-style-type: none"> <li>1. Close downstream valve and initiate 3-5 consecutive flush cycles.</li> <li>2. Switch to continuous flushing mode and gradually open downstream valve.</li> <li>3. Watch the DP, if stable – try to return to normal operation mode.</li> </ol>
	Too high flow rate	<ul style="list-style-type: none"> <li>• Reduce Flow</li> </ul>
	Too low working Pressure.	<ol style="list-style-type: none"> <li>1. Check Inlet and outlet pressure.</li> <li>2. Make sure working pressure is above 2.0 bar and DP is not more than 0.5 bar.</li> <li>3. Close downstream valve in order to eliminate the differential pressure.</li> </ol>
	Flushing valve did not open.	<ul style="list-style-type: none"> <li>• Verify that flushing valve is open and there is no interruption to the flushing flow.</li> </ul>
High DP + No Flushing	No power.	<ul style="list-style-type: none"> <li>• Verify Power supply.</li> </ul>
	Filter is in high DP fault mode.	<ul style="list-style-type: none"> <li>• Check the control system. RESET any potential Fault.</li> </ul>
High DP or Flow reduction + No flushing	DP switch is not reacting.	<ul style="list-style-type: none"> <li>• Check DP switch (Transmitter or switch) for fault or clogging. If switch is out of order it is possible to work according to short time intervals.</li> </ul>
Motor Over Load	Too high mechanical resistance.	<ol style="list-style-type: none"> <li>1. Check and verify that all scanners shafts and Cardan Joints are aligned.</li> <li>2. Make sure the transmission gear guide rods are firmly tightened.</li> <li>3. Reset the motor protector and check the current consumption.</li> </ol> <p>If problem cannot be solved:</p> <ol style="list-style-type: none"> <li>1. Disassemble the filter according to "Maintenance" Chapter.</li> <li>2. Inspect its internals.</li> <li>3. Perform SLN nozzle inspection.</li> <li>4. Assemble the filter.</li> </ol> <p><b>Do not force the motor by increasing the Ampere setting above the normal motor rating!</b></p>
Proximity switch Fault	Both limit-switches are OFF.	<ul style="list-style-type: none"> <li>• Check the proximity switches, probably one is out of order or disconnected</li> </ul>
Motor Time Out	A proximity switch failed to react.	<ol style="list-style-type: none"> <li>1. Check the proximity switch positioning.</li> <li>2. Re-adjust the proximity switches as described in chapter "Maintenance"</li> </ol>
	Threaded drive bushing or drive shaft key are damaged.	<ul style="list-style-type: none"> <li>• Check the transmission gear and drive mechanism and replace any damaged part.</li> </ul>
Motor is running downward (CW) and a signal is received from Top Proximity switch (or vice versa)	Wrong rotation direction of the motor due to wrong phase order.	<ul style="list-style-type: none"> <li>• Check and correct the motor wiring.</li> </ul>

## **13. Amiad Limited Warranty**

## Amiad Limited Warranty

This certificate applies to Amiad Products purchased by You from Amiad or an Amiad authorized Distributor (“Distributor”). This limited warranty extends only to the original purchaser, and is not transferable to anyone who subsequently purchases, leases, or otherwise obtains the Product from the original purchaser.

1. Amiad hereby warrants that the Products are and will be free from defects in material and workmanship under normal use and service. Amiad warrants that it will correct manufacturing defects in the Products, in accordance with the conditions set out in this warranty.
2. This warranty is enforceable for a period of 12 months after the date Bill of Lading or equivalent (the “Warranty Period”).
3. In the event that during the Warranty Period the Distributor discovers a defect in material and/or workmanship in any Product or part (the “Defective Product”), it shall submit a written complaint to Amiad using Amiad's standard customer complaint form. For the receipt of the customer complaint form, the submission of the complaint or any questions please contact your customer service representative.
4. Upon written demand by Amiad the Distributor shall return the Defective Products – or a sample thereof – to Amiad, at Amiad's cost. If the customer ships any such Product, Amiad suggests the customer package it securely and insure it for value, as Amiad assumes no liability for any loss or damage occurring during shipment. Provided however that in the event Amiad determines that the warranty does not apply to such Product, Distributor shall promptly reimburse Amiad for such cost (including freight and customs). Any returned Product or part must be accompanied by the warranty certificate and the purchase invoice. It is clarified that the Distributor may not return the Defective Product unless such return was coordinate and approved by Amiad in advance.
5. Amiad's obligation under this warranty shall be limited to, at its option, the repair or exchange, free of charge, of the Product or any part which may prove defective under normal use and service during the Warranty Period. The provision of a repaired or replacement Product during the Warranty Period will result in an extension of the Warranty Period by an additional period of 12 months, provided that the total accumulated Warranty Period shall in any event be no more than 18 months from the original Bill of Lading.
6. This warranty is valid on the condition that the Products are installed according to Amiad's instructions as expressed in Amiad's instruction manuals and according to the technical limitations as stipulated in Amiad's literature or as stated by a representative of Amiad.



7. This warranty will not apply to damaged or defective Products resulting from or related to:
  - (i) Fire, flood, power surges or failures or any other catastrophe/and or unforeseen occurrence, such as but not limited to those for which the customers are customarily insured;
  - (ii) Fault, abuse or negligence of the customer;
  - (iii) Customer's responsibilities, including the failure of the intake water to meet the agreed standards, as set forth in a written document, approved by Amiad or improper storage.
  - (iv) Improper or unauthorized use of the Product or related parts by the customer, including the customer's failure to operate the Product in conformity with the recommendations and instructions of Amiad, as set forth in Amiad's manuals and other written materials, the operation of the Product other than by a trained and qualified operator, or improper installation of the Product by a third party not authorized by Amiad;
  - (v) Performance by the customer of maintenance and other services other than by a trained and qualified advanced operator, or other than in conformity with the recommendations and instructions of Amiad, or other than in accordance with procedures defined in the literature supplied for Products;
  - (vi) Any alteration, modification foreign attachment to or repair of the Products, other than by Amiad or its authorized technical representatives.
8. In no event shall Amiad be liable to the customer or any third party for any damages, including indirect, special, exemplary, punitive or consequential damages, or lost profits arising out of or in connection with this warranty, or arising out of or in connection with the Product's performance or failure to perform, even if it has been advised of the possibility of such damages.
9. Amiad will be excused for failure to perform or for delay in performance hereunder if such failure or delay is due to causes beyond its reasonable control or force majeure preventing or hindering performance.
10. The limited warranty set forth herein is the only warranty given by Amiad and is provided in lieu of any other warranties created by any documentation, packaging or otherwise.

Amiad makes no warranty whatsoever in respect of accessories or parts not supplied by Amiad. In the event that Amiad is required to correct a defective Product or product not covered by this warranty, it will do so solely in consideration for additional fees.

## 14. Appendix