

AMIAD Water Systems

SAF-4500 FILTER

Serial number:	_____
Order number:	_____
Catalog number:	_____
Filtration degree:	_____
Tested by:	_____

Installation, Operation and Maintenance Instructions



Ref: 910101-000341/07.2019

AMIAD Water Systems

SAF-4500 SLN FILTER User Manual

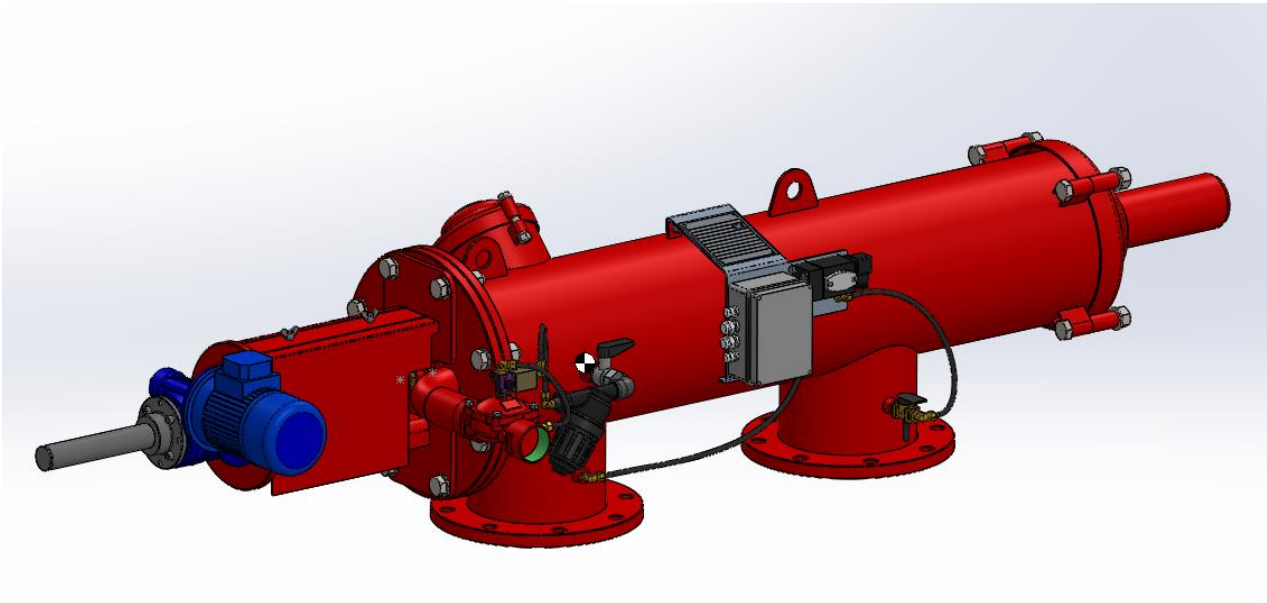

Disclaimer:

Copyright © 2017 Amiad Water Systems Ltd. All rights reserved.

The contents of this document, including without limitation all information and materials, images, illustrations, data, drawings, names and any other such materials that appear in this document are the sole property of Amiad Water Systems Ltd., including any intellectual property rights, whether registered or not, and all know-how contained or embodied therein. Amiad may alter, remove or change the Content without any further notice. You may not reproduce, copy, modify, create derivative works from, sell or participate in any sale of, or exploit in any way, in whole or in part, any of this document or its content.

The confidential nature of and/or privilege in the file enclosed is not waived or lost as a result of a mistake or error in this file. If you received this file in error, please notify Amiad immediately at info@amiad.com.

This document does not replace any certified drawing, procedure or information provided by Amiad in reference to a specific customer, site or project.

Amiad assumes that all users understand risks involved within this file and/or its attached materials. This document is given in good faith and is not intended to impose any obligation to Amiad. While every effort has been made to ensure the information in this manual is accurate and complete, we would appreciate if you can bring any errors or omissions to the knowledge of Amiad or consult Amiad experts or its authorized representatives if you have any questions.

Amiad Water Systems Ltd. D.N. Galil Elyon 1, 1233500, Israel Tel: 972 4 690 9500 | Fax: 972 4 814 1159 Email: info@amiad.com

TABLE OF CONTENTS

AMIAD Water Systems.....	1
SAF-4500 FILTER.....	1
Installation, Operation and Maintenance Instructions.....	1
SAF-4500 SLN FILTER User Manual	2
TECHNICAL SPECIFICATIONS	4
General	4
Flushing data.....	4
Control and electricity	4
Construction materials	4
Standard filtration degrees.....	4
SAFETY INSTRUCTIONS.....	5
General Safety Instructions	5
Installation	5
Commissioning.....	6
Operation and Control.....	6
Maintenance.....	7
RECOMMENDED INSTALLATION DRAWING	8
DESCRIPTION OF FILTER OPERATION.....	9
INSTALLATION	11
MAINTENANCE.....	13
TROUBLESHOOTING.....	15
DISMANTLING AND ASSEMBLING THE FILTER COMPONENTS	16
PARTS SCHEDULE – SAF-4500 FILTER – Section 1	18
PARTS DRAWING – SAF-4500 FILTER – Section 1 page 2.....	21
PARTS SCHEDULE AND DRAWING Section 2 – Drive Shaft Housing.....	22
PARTS SCHEDULE AND DRAWING - Section 3 - Scanner	23
PARTS SCHEDULE AND DRAWING - Section 3 - SLN Scanner	24
AMIAD LIMITED WARRANTY	25

With any inquiry please quote Filter Serial Number, located on the filter housing.

TECHNICAL SPECIFICATIONS

General

Maximum flow rate	250 m ³ /h	1100 USgpm	Consult manufacturer for optimum flow according to filtration degree and water quality
Min. working pressure	1.5 bar	21 psi	
Max. working pressure	10 bar	150 psi	16 bar (240 psi) upon request
Filter area	4500 cm ²	700 in ²	
Inlet/Outlet diameter	100, 150, 200 mm	4", 6", 8"	
Filter housing diameter	250 mm	10"	
Max. working temp.	60°C	140°F	
Weight	100 mm = 150 Kg	4" = 330 lb.	
	150 mm = 156 Kg	6" = 344 lb.	
	200 mm = 165 Kg	8" = 364 lb.	

Flushing data

Exhaust valve	50 mm	2"	
Flushing cycle time	20 seconds	20 seconds	
Flushing water per cycle	83 liter	22 gallon	at 2 bar (30 psi)
Minimum flow for flushing	15 m ³ /h	66 USgpm	at 2 bar (30 psi)

Control and electricity

Control voltage	24V AC (12V or 24V DC upon request)
Electric motor	1/4 HP 50 / 60 Hz, 35 / 42 Gear output R.P.M.
Rated operation voltage	3 phase 220 / 380 / 440 V, 50 / 60 Hz Single phase 110 / 220 V, 50 / 60 Hz
Current consumption	0.6 Amp. (with 3 phase 380 / 440 V)

Construction materials

Filter housing and lid	Epoxy-coated carbon steel 37-2 (Stainless Steel 316 available on request).
Screens	Stainless Steel 316
Cleaning mechanism	Stainless Steel 316, POM
Exhaust valve	Epoxy-coated cast iron, Natural Rubber
Seals	Synthetic Rubber
Control system	Aluminum, Brass, Stainless Steel, PVC

Standard filtration degrees

	Stainless Steel Weave Wire Screen								
micron	500	300	200	130	100	80	50	20	10
mm	0.5	0.3	0.2	0.13	0.1	0.08	0.05	0.02	0.01

SAFETY INSTRUCTIONS

General Safety Instructions

- Amiad filtration products always operate as components in a larger system. It is essential for the system designers, installers and operators to comply with all the relevant safety standards.
- Prior to installation, operation, maintenance or any other type of action carried out on the filter, read carefully the safety, installation and operation instructions.
- During installation, operation or maintenance of the filter all conventional safety instructions should be observed in order to avoid danger to the workers, the public or to property in the vicinity.
- Please note: The filter enters into a flushing mode automatically, without prior warning.
- No change or modification to the equipment is permitted without a written notification given in advance by the manufacturer or by its representative, on the manufacturer's behalf.
- Always observe standard safety instructions and good engineering practices whilst working in the filter's vicinity.
- Use the filter only for its intended use as designed by Amiad, any misuse of the filter may lead to undesired damage and may affect your warranty coverage. Please consult with Amiad prior to any non-regular use of this equipment.

Installation

General

- Install the filter according to the detailed Installation Instructions provided with the filter by the manufacturer and according to the description given in this manual.
- Make sure to leave enough clearance so as to enable easy access for future treatments and safe maintenance operations.
- The user should arrange suitable lighting at the area of the filter to enable good visibility and safe maintenance.
- The user should arrange suitable platforms, ladders and safety barriers to enable easy and safe access to the filter without climbing on pipes and other equipment. The user should verify that any platform, barrier, ladder or other such equipment is built, installed and used in accordance with the relevant local authorized standards.
- Check and re-tighten all bolts during commissioning and after the first week of operation.
- Use only appropriate standard tools and equipment operated by qualified operators when installing, operating and maintaining the filter.
- When installation is required in hazardous environment sites, underground or high above ground, make sure that the site design and the auxiliary equipment are appropriate and that installation procedures are carried out in accordance with the relevant standards and regulations.
- Ensure walking areas about the installation are slip free when wet.

Shipment and transporting

- Shipping and transporting the filter must be done in a safe and stable manner and in accordance with the relevant standards and regulations.
- For shipping, lifting and positioning the filter, use only approved lifting equipment and authorized employees and contractors.

Electricity

- Electric wiring should be performed by an authorized electrician only, using standardized and approved components.
- Install a **lockable** main power cut-off switch close to the control panel.
- If due to site constraints, the control panel is installed without a clear line-of sight of the filter, an additional **lockable** power disconnect cut-off switch should be installed near each filter unit.
- Installation of the filter should be performed so as to avoid direct water splashing on the electrical components or on the control panel.

Pneumatics

- Install a **lockable** main cut-off switch, **featured with a pressure release mechanism**, on the compressed air supply line close to the control panel.
- If the control panel is installed far away and there is no eye contact with the filter, a **lockable** compressed air cut-off switch, **featured with a pressure release mechanism**, should be installed near each filter unit.
- The user should make sure that the compressed air supplied to the filter never exceeds the maximum designated pressure for this filter. An air-pressure reduction valve should be installed on the compressed air supply line upstream of the filter's pneumatic inlet port.

Hydraulics

- Extra safety devices should be installed on hot water applications to avoid skin burn danger.
- The user should install a manual Water Cut-off Valve next to the filter's inlet port.
- In cases where the downstream piping network downstream of the filter is pressurized an additional manual Water Cut-off Valve should be installed next to the filter outlet port.
- The user should make sure that the system includes a Pressure Release / Drainage Valve to enable release of residual pressure prior to any maintenance procedure performed on the filter.
- The user should make sure that the filter is never exposed to water pressure exceeding the maximum designated pressure for this filter, if needed a Pressure Reduction Valve should be installed upstream of the filter's water inlet port.
- Please note that the maximum working pressure indicated at the filter's specifications table includes the pressure caused by fluid hammer and pressure surge effects.

Civil Engineering

- Make sure that the filter installation is done by Amiad qualified technicians.
- Make sure that any civil engineering work at the installation site such as construction, lifting, welding, etc. is done by qualified workers / technicians / contractors and in accordance with the relevant local standards.
- While using lifting equipment, make sure that the filter or the lifted part is chained securely and in a safe manner.
- Do not leave lifted equipment if there is no necessity. Avoid working below lifted equipment.
- Wear a safety helmet while using lifting equipment.
- Make sure that the flooring is sloped for drainage and to avoid accumulation of liquids.

Commissioning

- Read carefully the Commissioning and the First Start-up Operation instructions prior to any attempt to operate the filter.
- In order to achieve maximum performance and smooth operation of the filter it is crucial to perform the Startup and First Operation procedures exactly as described in this manual.
- Commissioning the filter should be done by an authorized Amiad technician, do not attempt to commission the filter unaccompanied since this may lead to undesired damage and may affect your warranty coverage.

Operation and Control

- Do not operate the filter before reading carefully and being familiar with its operation instructions.
- Observe the safety stickers on the filter and never perform any operation contradicting the instructions given.
- Never operate or use the filter for purposes other than its original design and operational envelope.

Maintenance

Before any maintenance or non-regular operation please read the following:

- Servicing the filter should be done only by technicians authorized by Amiad.
- Disconnect the filter from the power supply and lock the Main Power Switch.
- Disconnect the compressed air supply, release the residual pressure and lock the Pneumatics Main Valve.
- Disconnect the filter from the water system by closing and securing the Manual Inlet Valve. In cases where the downstream piping network is pressurized, close and secure the Manual Outlet Valve also.
- Release the residual water pressure by opening the Pressure Release / Drainage Valve.
- Empty the filter by opening the Drainage Valve.
- In hot water systems wait till the filter components cool off to a safe temperature.
- Place warning signs around the work area as required by the local standards and procedures.
- Inspect the filter's safety stickers and replace any damaged or faded sticker.

Mechanical

- When working on the filter use only appropriate standard tools.
- Always open and close valves slowly and gradually.
- Remove grease and fat material residues in order to avoid slipping.
- Before disconnecting the filter from the water supply, electricity and pneumatics and before releasing the filter's residual pressure do NOT:
 - loosen or unscrew bolts
 - remove any protection cover
 - open any service port flange
- Avoid splashing and water leakage so as to minimize slippage, electrification or damage to the equipment, caused by moisture.
- While using lifting equipment, make sure that the filter or the lifted part is chained securely and in a safe manner.
- Do not leave lifted equipment if there is no necessity. Avoid working below lifted equipment.
- Wear a safety helmet, goggles, gloves, and any other personal safety equipment required by the local standards and regulations.
- Human entry into a filter must be done in accordance with the relevant local safety instructions, standards and regulations for working in hazardous environment.
- Manual cleaning of filter media using high water pressure or steam should be performed in accordance with the cleaning system instructions, the local standards and regulations and without endangering the operator or the vicinity
- Manual cleaning of filter element using acid or other chemical agents should be performed in accordance with the relevant material safety instructions, the local standards and regulations and without endangering the operator or his vicinity.

Before returning to regular operation

- Re-assemble any protection covers or protection mechanisms removed during service or maintenance operations.
- Make sure that all the tools, ladders, lifting devices, etc. used during the maintenance procedures are taken away from the filter area and stored
- In order to return the filter to regular operation, follow the First Start-up Operation instructions as detailed in your user manual.
- For filters used in potable water systems it is required to disinfect the filter according to the local water authority standards and regulations before putting it back to service.

RECOMMENDED INSTALLATION DRAWING

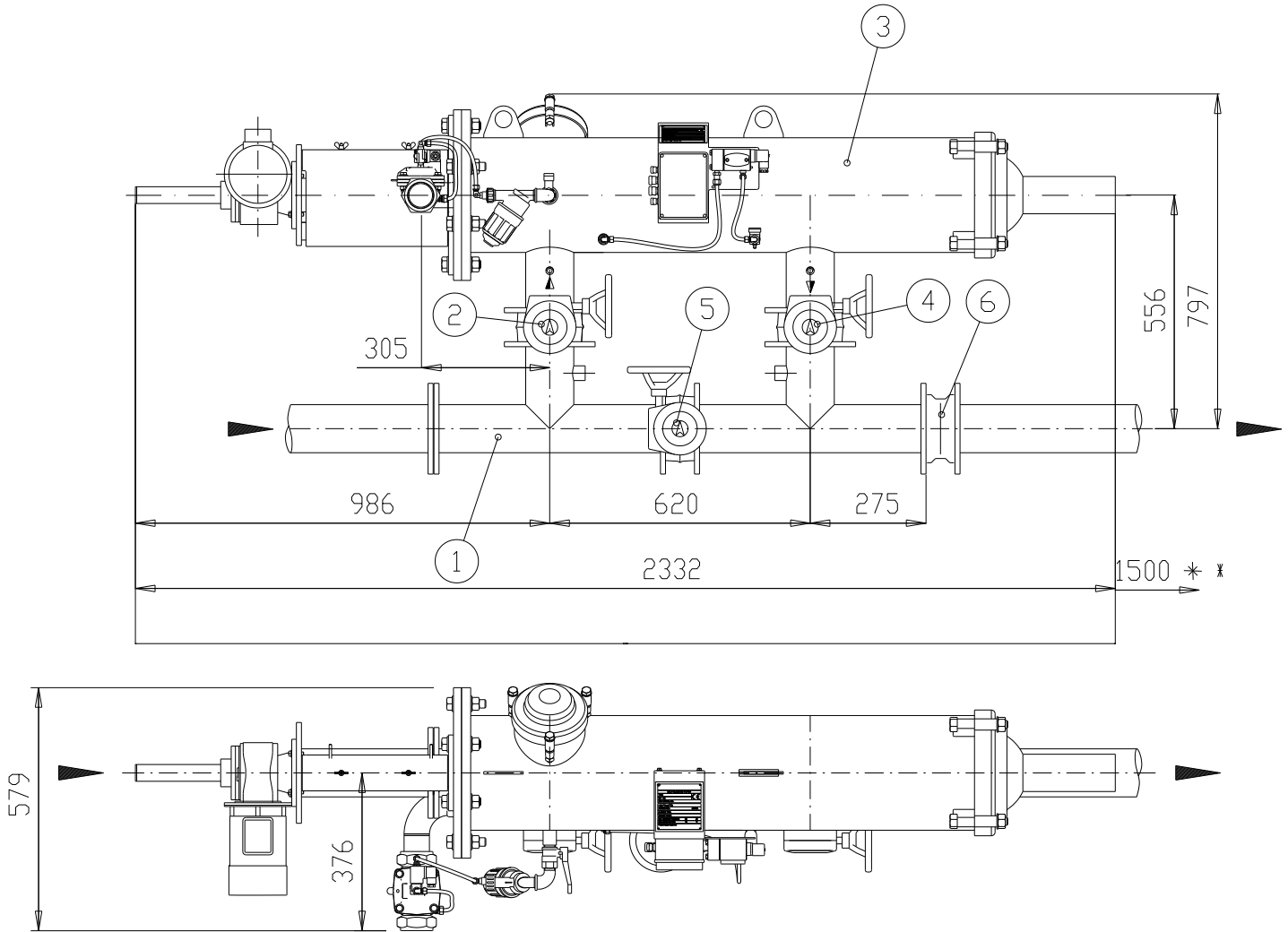

KEY:

1. 4" INLET MANIFOLD
 2. 4" INLET BUTTERFLY VALVE
 3. 4" SAF-4500 FILTER
 4. 4" OUTLET BUTTERFLY VALVE
 5. 4" BY-PASS BUTTERFLY VALVE
 6. 4" NON RETURN VALVE
- * Minimum length for opening

DESCRIPTION OF FILTER OPERATION

Filtering process:

The SAF-4500 is a sophisticated yet easy-to-operate automatic filter, with a self-cleaning mechanism driven by an electric motor. The SAF-4500 is designed to work with various types of screens in filtration degrees from 10 to 500 micron, and is available in 4", 6" and 8" inlet/outlet diameter.

The water enters through the inlet pipe into the coarse screen from outside in, and through the fine screen from inside out. The "filtration cake" accumulates on the fine screen surface and creates head loss to develop.

The coarse screen is designed to protect the cleaning mechanism from large dirt particles. Usually, it does not accumulate large quantities of suspended solids and is not cleaned automatically.

Self-cleaning process:

The SAF-4500 initiates the self-cleaning process when either the pressure differential across the screen reaches a pre-set value or the flush timer reaches its preset timed interval.

The fine screen filter element is cleaned by the suction scanner, which rotates in a spiral movement while removing the filtration cake from the screen, and expels it out through the exhaust valve.

A 2-way (fwd/rev) drive unit that is attached to the scanner by a threaded shaft rotates the scanner and provides the linear movement.

The exhaust valve is activated for the duration of the cleaning cycle by a 3-way solenoid. During the 20 seconds self-cleaning process, filtered water continues to flow downstream.

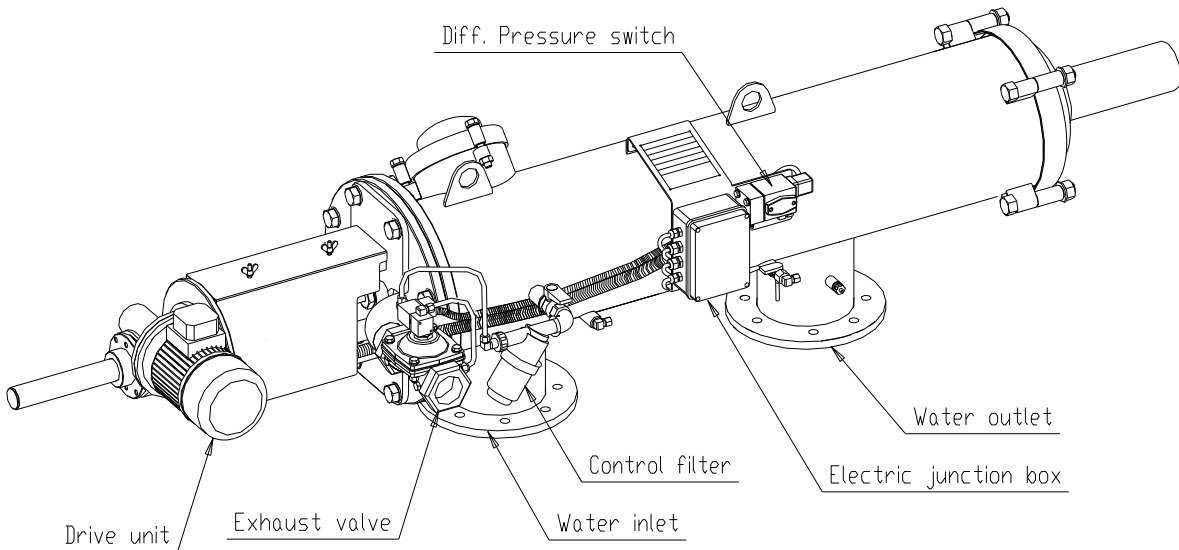

System Operation modes:

The filtration system may be found in one of the following modes:

1. Filtering mode: This is the normal operating status. The flush mode is idle and the power light on the control board is lit.
2. Flush mode: The motor and exhaust valve activate according to the previously described self-cleaning process.
3. Continuous flushing mode: It is possible to activate the self-cleaning mechanism continuously by setting the SW1 switch in the control board to "CONT." position.
4. Malfunction mode: If the filter malfunctions, the self-cleaning operation stops, the malfunction light on the control board is turned on and a 24V AC external output is activated.

The filtration system enters a malfunction mode under any of the following conditions:

- 1st. A continuous signal from the pressure differential switch longer than the PD fault time-out (default value=15 minutes) indicates that the filter is unable to clean itself.
- 2nd. The motor Over Load protector was activated, either manually or due to actual over load.
- 3rd. Limit Switch malfunction - (usually, simultaneous activation of both limit switches).

Initiation of self-cleaning:

The filter initiates the self-cleaning process under any one of the following conditions:

1. PD flush - The Pressure Differential Switch (PDS) closes a free potential contact signal when the pressure differential across the screen reaches the pre-set value (usually 0.5 bar =7 psi). The control board registers the signal and activates the flushing cycle.
2. Test flush - Manually pressing the "TEST" push button on the control board door activates a single flushing cycle.
3. Timed flush - SW1 must be in the DP/Time position. The T1 timer in the control panel activates the flushing cycles at time intervals, regardless of the pressure differential. The timer resets after every flushing cycle. The PD flush mode is active in this mode as well.
4. Continuous flush - SW1 must be in cont position. In this mode the filter flush continuously. This mode is for use in extraordinary circumstances and for a limited time. Please consult with the manufacturer regarding the uses of this mode.

Control system:

Two types of control boards are available: PLC Type and Relay Type. See Appendix A or B for details.

INSTALLATION

Design recommendations:

1. Often, flow increases and pressure drop dramatically during fill-up of a water system. In this case, a pressure-sustaining valve installed downstream of the filter will ensure the minimum required pressure for the filter and a controlled filling-up of the line.
2. If constant water flow is required even during maintenance, it is recommended that a manual or automatic by-pass be installed. Isolating valves will be used to isolate each filter unit.
3. In applications where the water quality periodically worsens, it is possible to operate an emergency flush program. In order to do so, an automatic Down Stream valve must be installed. For details, please consult the manufacturer.

Installation instructions:

1. Install the filter horizontally in a manner that will allow convenient access and enough space to dismantle the filter for maintenance purposes.
2. Check the direction of flow according to the arrows marked on the filter housing.
3. It is recommended to install a mechanical non-return valve downstream of the filter.
4. The exhaust line (minimum 2" diameter) should be designed so that it creates minimal resistance to flow of 11 m³/h (50 USgpm).
5. If the system is designed to operate with working pressure higher than 6 bar (85 psi), it is recommended that a manual throttling valve be installed on the exhaust line, in order to enable regulation of the flushing flow rate.
6. The user should arrange suitable lighting at the area of the filter to enable good visibility and safe maintenance.
7. The user should arrange suitable platforms and safety barriers to enable easy access to the filter without climbing on pipes and other equipment.

IMPORTANT !!

- ◆ Prevent static back-pressure or reverse flow through the filter.
- ◆ Install a manual or a hydraulic valve downstream of the filter.

Electric wiring

1. Install the control board in a dry and protected place (It is possible to order a special control board for severe out-door installation).

For single phase or DC power supply, please refer to the electrical drawing inside the control board.

2. **Power connection to the control board:**
 - a. Connect a three-phase power source through a semi-automatic switch, or 16 Amp. fuse to the L1 L2 L3 connectors at the terminal strip in the control board.
 - b. Ground the control board.
3. **Power connection to the motor:** Connect the drive unit to the control panel using 4 x 2.5 mm (12 or 14 AWG) wires in flex-conduit. Use a long enough cable to allow removal of the drive unit and placing it near the filter for maintenance, without having to disconnect it from the cable. (The installation should meet or exceed local or national electrical codes for "high" voltage).
4. **Control wiring:** Connect the terminals between the junction box and the control panel using 6 x 1.5 mm (16 AWG) wires in flex-conduit. The numbers on the terminals in the board correspond with those in the junction box.

Start-up and first operation

1. Make sure all the electric wiring is correct, according to the enclosed drawings.
2. Switch ON the control & 24V circuit breakers and the motor protector O.L. The motor will start operating *.
3. CHECK ROTATION: The suction scanner shaft should turn clockwise (CW) and move towards the filter housing until it reaches limit switch "A". If the motor rotates in the opposite direction (CCW), turn off the electricity immediately and change the direction of the motor rotation by changing between two phases.
4. The motor must stop when the limit switch plate reaches limit switch "A" (opening the NC circuit).
5. Operate a "dry" flushing cycle by pressing on the "TEST" push button. Check that the flushing cycle runs as described in the "Self-cleaning process" paragraph in this manual.
6. Open the inlet valve to the filter, leaving the outlet valve closed or with an open by-pass valve (This will keep the flow through the filter to a minimum), and operate a flushing cycle.
7. Check that the exhaust valve opens and all stages of the flushing cycle perform properly. Attend to leakage, if any.
8. Close the 1/4" valve at the low pressure sensing port of the pressure differential switch for 5 seconds. The PDS hand will move to the red area and the filter will start the flushing process. Re-open the 1/4" valve.
9. Gradually open the outlet valve and/or close the by-pass valve. Operate the filter under the designed hydraulic conditions.
10. Set the flushing interval timer (T1) for 6-8 hours.
11. Check and re-tighten all bolts after the first week of operation.

When using Control board type "C" (Relay type) it is necessary to press the "Test" push button in order to start the motor operation for the first time.

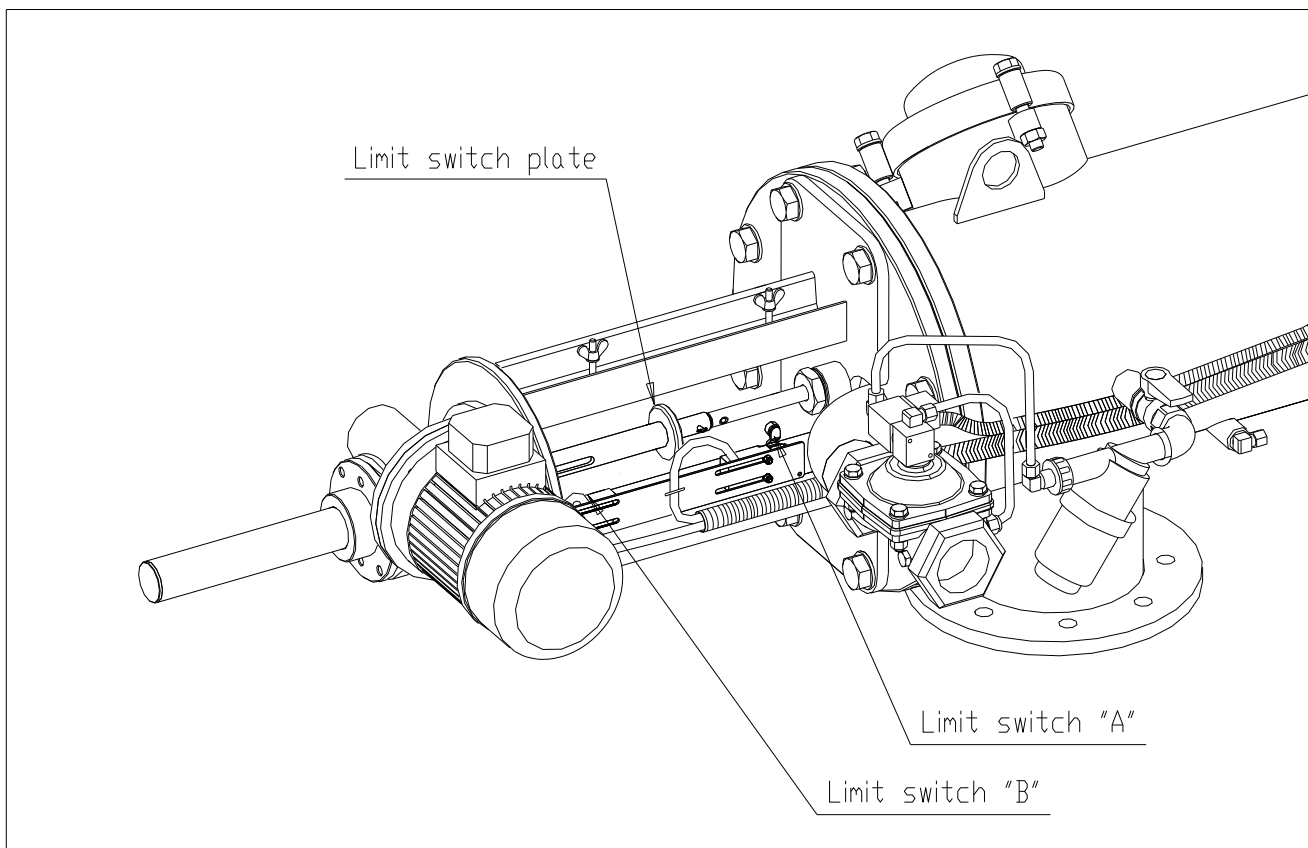

MAINTENANCE

General inspection

Initiate a flush cycle by closing the 1/4" valve at the low pressure sensing port of the pressure differential switch for 5 seconds. Check that the exhaust valve opens, that the scanner moves properly, and when it reaches the limit switch - verify that the exhaust valve closes.

Weekly maintenance:

1. Perform a general inspection as described above.
2. Clean the 3/4" filter connected to the exhaust solenoid. (Close the 3/4" valve and activate a flush cycle in order to release pressure and then unscrew the filter bowl).
3. Check that there is grease on the drive shaft, and drive bushing. Add grease if necessary.
4. Check for any leakage from the scanner shaft. If necessary, replace the sealing nut internal O-ring (40)

Changing the sealing nut internal O-ring:

1. Close the inlet valve to the filter and release the pressure.
2. Remove the cover (35) from the drive shaft housing (14) by unscrewing the wing nuts.
3. If the Suction Scanner is in the outer position, operate a flush cycle and bring it to the inner position.
4. Remove the split pin (20) and pull out the connecting pin (19).
5. Operate a flush cycle.
6. Power down the unit when the drive shaft is half way through its cycle. The drive shaft is now separated from the suction scanner.
7. Unscrew the sealing nut (38).
8. Remove the used internal O-ring and clean the O-ring seat.
9. Insert a new O-ring (40)
10. Apply some grease on the external O-ring and on the shaft.
11. Tighten the sealing nut (38).
12. Re-connect the drive shaft to the suction scanner shaft.
13. Operate the control board and open the filter inlet valve.

Maintenance prior to long term shutdown (end of season):

The following must be done if the filter will not be in operation for longer than a month.

1. Perform a flush cycle (If possible, with a closed downstream valve).
2. Release pressure from the filter.
3. Power down the unit when the drive shaft is half way and none of the limit switches is pressed.
4. Disconnect the power supply to the control board.
5. Grease the drive shaft and the drive bushing.
6. Clean the 3/4" control filter.
7. Clean the coarse screen.

Maintenance prior to renewing filter operation:

1. Connect the control board to the power supply.
2. Check proper operation of the filter, especially noting proper rotation.
3. Grease the drive shaft and the drive bushing.
4. If necessary, change the sealing nut internal O-ring.

IMPORTANT!!

THE DRIVE SHAFT MUST BE LUBRICATED WITH HEAVY-DUTY, WATER RESISTANT GREASE THAT WILL NOT OXIDIZE. (SHELL, DARINA EP-2 OR SIMILAR).

Cleaning the coarse screen:

1. Close the filter inlet valve.
2. Release pressure from the filter by performing a flush cycle.
3. Remove the service lid (24) by disconnecting the bolts (26) from the nuts (28)
4. Clean the coarse screen:
 - To remove large particles insert your hand into the coarse screen area.
 - To remove fine particles and organic matter rinse the screen. Afterwards, partially open the inlet valve and let water flow out.

TROUBLESHOOTING

Before beginning any troubleshooting, carefully read the safety instructions in chapter 2 of this document and make sure that all the workers at the filtration site are fully aware of and comply with, these and any other local safety instructions.

The filtration system may enter a malfunction mode in the following cases:

Symptom	Remarks and Actions
<p>Fault due to continuous signal from the pressure differential switch for duration of more than 15 minutes.</p> <p>The fault indication lamp is lighted in red</p>	<p>This fault means that the self-cleaning process is not successful.</p> <p>This fault may be caused by one of the following reasons:</p> <ul style="list-style-type: none"> The filter is clogged due to heavy dirt load or too high water flow rate. Close the filter's downstream valve. Press the reset button to reset the fault mode. The fault indication lamp is turned off. Perform few consecutive manual flush cycles and monitor the PD signal. Once the filter is clean gradually open the downstream valve and monitor the PD and the flow-rate. Make sure that the filter doesn't exceed its designated flow-rate. The PD switch is faulty. Ask your qualified electrician to check the PD connections and operation. Replace the switch if found faulty.
<p>The motor protector was activated</p> <p>The fault indication lamp is blinking in red</p>	<p>This fault means that the motor was operated under too high load</p> <p>Note: All the following checks and actions should be done by a qualified electrician only.</p> <ol style="list-style-type: none"> Check the motor power consumption when not loaded. Check the limit switches for correct operation and verify that each one of them stop the motor at its designated point. Verify 3 phase 380VAC power supply to the control board and the motor. Disconnect the drive unit from the suction scanner shaft and verify free turning of the suction scanner. <p>Note: If during this fault a request for flushing is received (Manual, Time or DP) the blinking lamp switches to constant red.</p>
<p>Malfunctioning limit switches</p> <p>The fault indication lamp is blinking in red</p>	<p>Faulty limit switch may not stop the motor at the right point and therefore the motor protection may be activated.</p> <p>Receiving signal from both limit switches at the same time causes fault</p> <ol style="list-style-type: none"> Check that the limit switches are not mechanically stuck. Ask your qualified electrician to check the wiring and the functionality of the limit switched. <p>Note: If during this fault a request for flushing is received (Manual, Time or DP) the blinking lamp switches to constant red.</p>
<p>The fault indication lamp is blinking in red after the reset button is pressed</p>	<p>This means that the mechanical/electrical fault still exists. (Overload or Limit Switches faults)</p>

DISMANTLING AND ASSEMBLING THE FILTER COMPONENTS

Prior to opening the filter perform a flush cycle by pressing the "TEST" push button.

The Fine screen

Dismantling:

1. Close the filter inlet and outlet valves and release the pressure.
2. Release the lid bolts (23) from their nuts and remove the lid (21).
3. Pull the screen (17) out of the filter housing.
4. Remove the screen seals (16) from the screen.

Assembly:

1. Put the screen seals (16) on the screen edges (17).
2. Insert the screen into the filter housing (1) while the support legs point upwards. After pushing the screen all the way in, rotate the screen so the legs will support it and lead it to its position.
3. Clean and apply some grease on the suction scanner pipe and on the o-ring of the lower bearing (4).
4. Assemble the lid on the filter housing. Make sure the screen and seal are correctly positioned in the lid seat.
5. Tighten the bolts (23) in a controlled and balanced method. The bolts seats of the lid should touch the bolts seats of the filter housing.
6. Open the filter inlet and outlet valves and operate the control board.
7. Check proper operation of the filter.

The suction scanner:

Dismantling:

1. Begin the dismantling procedure as per 1-4 in the chapter "dismantling the fine screen".
2. Remove the cover (35) from the drive shaft housing (14) by unscrewing the wing nuts.
3. Remove the Split pin (20) and pull out the connecting pin (19).
4. Pull the suction scanner (18) in a spiral movement out of the filter housing.
5. Unscrew the sealing nut (38).

Assembly:

1. Apply some grease on the smooth side of the suction scanner (18) and insert it into the screen (17). Make sure the scanner (18) passes through the flushing chamber (3). When the suction scanner shaft appears from its port, apply some grease on it and tighten the sealing nut (38).
2. Insert the suction scanner shaft (2 on page 23) into the drive shaft (3 on page 22). Make sure the holes in the above shafts are parallel.
3. Insert the connecting pin (19) to the parallel hole of the suction scanner shaft and the drive shaft and lock it with the split pin (20).

The drive shaft housing and coarse screen:

Dismantling:

1. Close the inlet and outlet valves of the filter and release pressure.
2. Disconnect power supply from the control board.
3. Dismantle the suction scanner and fine screen as described previously.
4. Pull out the plug from the solenoid coil (60).
5. Remove the limit switch sling (6 on page 22) from the drive shaft housing by unscrewing the bolts (14 on page 22). Carefully put the limit switch sling near the filter to avoid any damage to the electrical wires.
6. Disconnect the tube (70) from the solenoid valve (60) and from connector (44).
7. Disconnect the drain pipe from the exhaust valve.
8. Remove the drive shaft cover (35) by unscrewing wing nuts.
9. Remove the drive unit (30) from the drive shaft housing (14) by unscrewing the nuts (33) from the bolts (31). By doing so the drive shaft key (29) will be pulled out.
10. Dismantle the drive shaft housing (14) from the flushing chamber flange (3) by unscrewing the bolts (15).
11. Remove the rest of the flange bolts and pull out the flushing chamber assembly which includes: flushing chamber (3), coarse screen (7), screens adapter (9) and screens adapter seal (10).

Assembly:

1. Place the coarse screen (7) in its seat in the flushing chamber.
2. Place the screens adapter (9) on the flushing chamber and the coarse screen.
3. Attach the screens adapter seal (10) to its place with its flat side, using some grease (as adhesive material).
4. Attach the flushing chamber o-ring (6) to its place using some grease (as adhesive material).
5. Apply some grease on the o-ring of the upper bearing (4).
6. Insert the flushing chamber assembly into its place. Use the centering pin to locate the flange in its position.
7. Tighten the flange to the filter housing with the side bolts only (11).
8. Apply some grease on the o-rings (39 & 40) of the shaft sealing nut (38) and tighten to its place.
9. Install the drive shaft housing, using the rest of the flange bolts (15).
10. Insert the suction scanner (18) and the fine screen (17) as described previously.
11. Connect the drive shaft (3 on page 22) to the scanner shaft using the connecting pin (19) and split pin (20).
12. Make sure the drive shaft key (29) is fitted properly in the gear box. Thread the drive shaft through the drive unit and make sure that the drive shaft groove is adjusted in accordance with the drive shaft key.
13. Connect the drive unit (30) to the drive shaft housing (14) with the bolts (31) and tighten them.
14. Connect the pilot tube between the solenoid valve (60) and the control filter connector (52).
15. Assemble the limit switch sling (6 on page 22) in its place and push in the plug of the solenoid coil.
16. Connect the drain pipe to the exhaust valve (68).
17. Operate the control board and make sure the filter is operating properly.
18. Open the inlet and outlet valves and recheck filter operation.

PARTS SCHEDULE – STANDARD SAF-4500 FILTER – Section 1

No.	Description	Qty
1	SAF-4500 Housing Red	1
2	Slotted Pin 10x30 DIN1481	1
3	SAF-4500 Flushing Chamber,Red	1
4	Suction Scanner Bearing (SAF-4500)	2
5	Locking Spring RING (SST316)	2
6	O-Ring 60X4 Flushing Chamber NBR	2
7	Coarse Screen SAF-4500	1
8	Parker Standard O-ring series P2-452	1
9	Coarse Screen Adaptor SAF-4500 Red	1
10	Flushing Chamber Seal AM-10 (SAF-4500)	1
11	Hex Bolt Partial Thread M20X70 Z.PLT C/ST	4
12	Flat Washer M20 DIN125 Zinc Plated C/ST	20
13	Hex Nut M20 Zinc Plated C/ST DIN934	12
14	Drive Shaft House Assembly, Red SAF-4500	1
15	Hex Bolt Partial Thread M20X80 Z.PLT C/ST	4
16	Hydraulic Seal AM-05	2
17	Weavewire S/ST316 4500SQ.CM Screen /SAF4500	1
18	SLN Scanner Assembly (Improved) SAF-4500	1
18	Scanner Assembly (Improved) SAF-4500	1
19	Connecting Pin (SAF-1500,3000, 4500)	1
20	Split Pin 1.6X12 DIN94 S/ST316	1
21	Lid (SAF-4500) Red	1
22	Hydraulic Seal AM-08	1
23	Hex Bolt Full Thread M20X120 Z.Plated C/ST	4
24	SAF-4500 Service Port Lid Red	1
25	Servic Port Lid Seal AM-12 (SAF-4500)	1
26	Hex Bolt Partial Thread M12X80 Z.PLT C/ST	3
27	Flat Washer M12 DIN125 Zinc Plated C/ST	3
28	Hex Nut M12 Zinc Plated C/ST DIN934	3
29	Drive Shaft Key (SAF)	1
30	Drive Unit SAF1500-4500 440VAC 3Ph 0.18KwX1400 RMI50 1/28 63 B5	1
31	Hex Bolt Full Thread M8X40 Z.Plated C/ST	4
32	Flat Washer M8 DIN125 Zinc Plated C/ST	8
33	Hex Nut M8 Zinc Plated C/ST DIN934	4
34	Spring.W M8 DIN127 Zinc Plated C/St	4
35	Drive Shaft Housing Cover SAF1500 EPOXY PKPK-3002	1
36	Drive Shaft Cover (PVC) SAF	1
37	Socket Head Cap Screw M8X20 S/ST304 DIN912	4
38	SAF-4500 Tightening Nut	1
39	O-Ring Seal 14x3 Nbr "S"	1
40	O-Ring Seal 24x3 (Tightening Nut SAF)Nbr"S"	1
41	Pressure Check Point Connector 1/4"X1/4"	3
42	Pressure Check Point Plastic W/O Nipple	2
43	Manometer Valve 1/4" W/Drain	1
44	L-Connector 5/16"X1/4"	4
45	Insrtumentation Combined Bracket SAF	1

No.	Description	Qty
46	Electrical Junction Box (SAF)	1
47	Pressostat Sub-As. Midwest w/o Fitting & Electric Cable	1
48	Connector 5/16"x1/8"	1
49	L-Connector 5/16"x1/8"	2
50	Ball Valve 3/4" M/F (BRASS)	1
51	L-Connector 3/4" F/M Galvanized	1
52	Housing 3/4" (AC,Black) BSPT	1
53	Molded Nylon 110SQ.CM S200MIC F/3/4"AC	1
54	3/4" Bowl- Closed (AC,Black)	1
55	Raccord Nipple 1/4" for 3/4" Filter	1
56	O-Ring Seal P2-112 NBR	1
57	Raccord Nut 3/4" for 3/4" Filter	1
58	2" Bermad Hydraulic Valve (RAM) BSP RED	1
59	Connector 5/16"x1/4"	1
60	Solenoid Valve 24VAC,50HZ,No (Gem-Sol)	1
61	Phillips Pan Machine Screw M5X16 304	4
62	Hex Nut M5 S/ST304 DIN934	4
63	Flat Washer M5 DIN125 S/ST304	4
64	Hex Bolt Full Thread M6X20 S/ST304 DIN933	2
65	Flat Washer M6 DIN125 S/ST316	4
66	Hex Nut M6 S/ST316 DIN934	2
67	Spring Washer M6 DIN127 S/ST316	2
68	Aluminum Amiad Nameplate, CE, EN	1
69	Rivet Blind 3x6 DIN7337 S/ST316	4
70	Pipe 5/16" PA Air Brake	1

**PARTS DRAWING – STANDARD SAF-4500 FILTER –
Section 1 page 1**

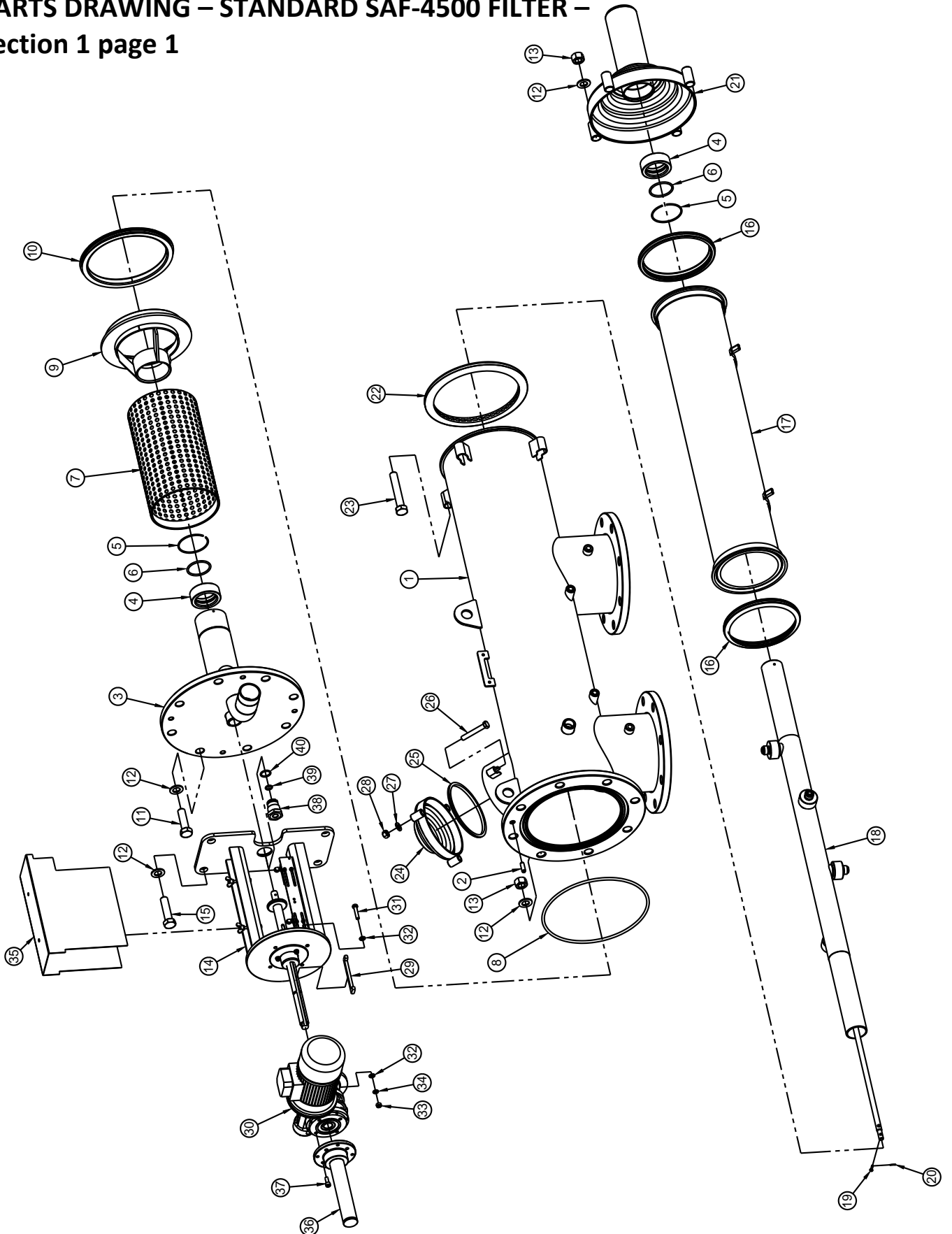

PARTS DRAWING – STANDARD SAF-4500 FILTER
Section 1 page 2

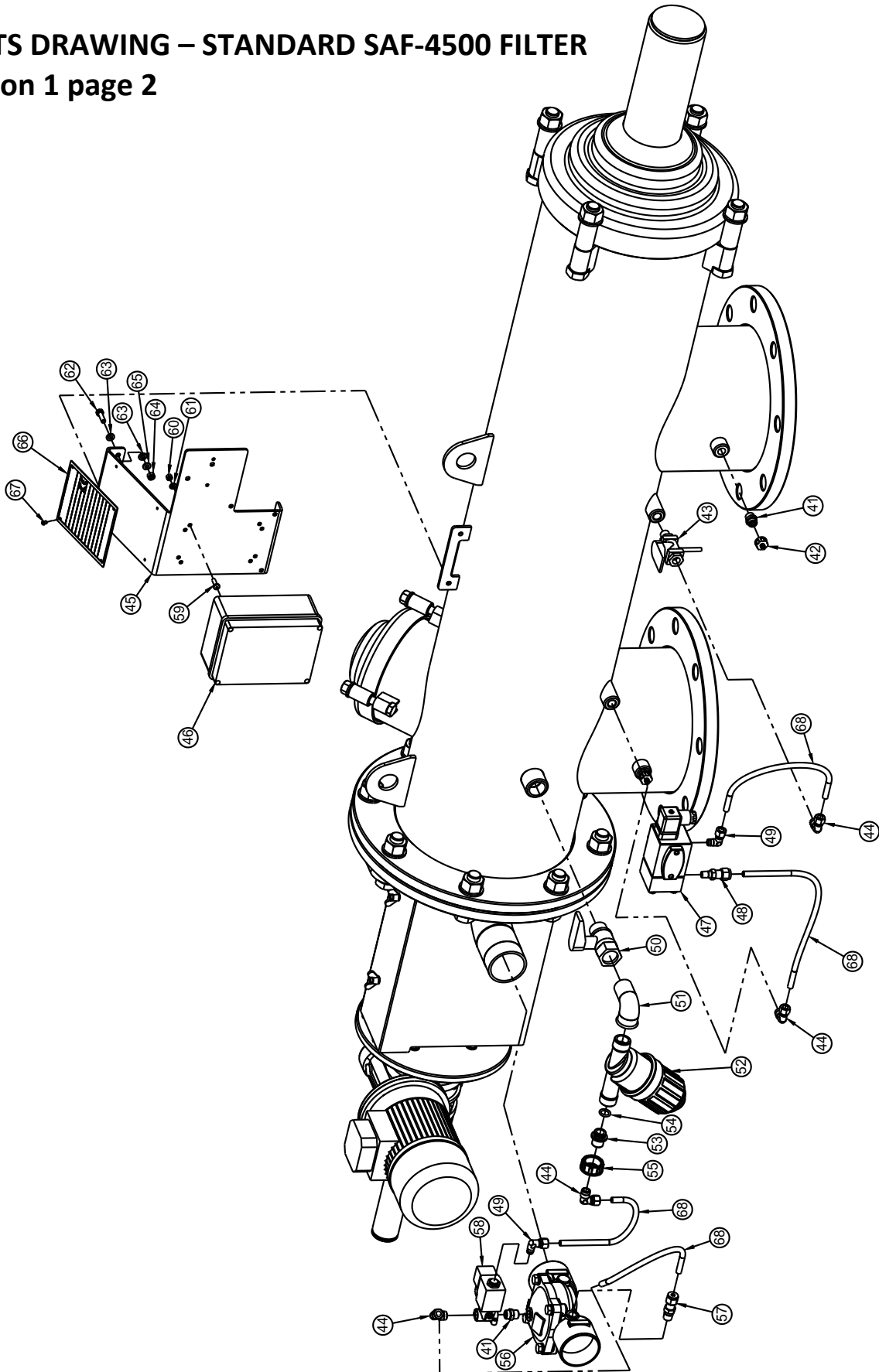

PARTS SCHEDULE AND DRAWING STANDARD SAF 4500

Section 2: Drive Shaft Housing

No.	Description	Qty
1	Drive Shaft House SAF-4500 Epoxy PKPK-3002	1
2	Drive Bushing (SAF)	1
3	Drive Shaft (SAF-1500,3000,4500)	1
4	Limit Switch Plate (SAF) HD	1
5	Limit Switch Plate Locking Ring	1
6	HD Limit Switch Sling (SAF)	1
7	Limit Switch NC (EBS,SAF)	2
8	Phillips Pan Machine Screw M4x20 DIN7985	4
9	Flat Washer M4 DIN125 S/ST304	4
10	Nylon Insert Lock Nut M4 S/ST304 DIN985	4
11	Hex Bolt Full Thread M6x35 DIN933 S/St.316	3
12	Flat Washer M6 DIN125 S/ST316	16
13	Nylon Insert Lock Nut M6 S/ST304 DIN985	3
14	Hex Bolt Full Thread M6x20 S/St304 DIN933	2
15	Spring Washer M6 DIN127 S/ST316	2
16	Hex Nut M6 S/ST316 DIN934	4
17	Hex Bolt Full Thrd M6x60 S/St304 DIN933	2
18	Wing Nut M6 304 DIN315	2

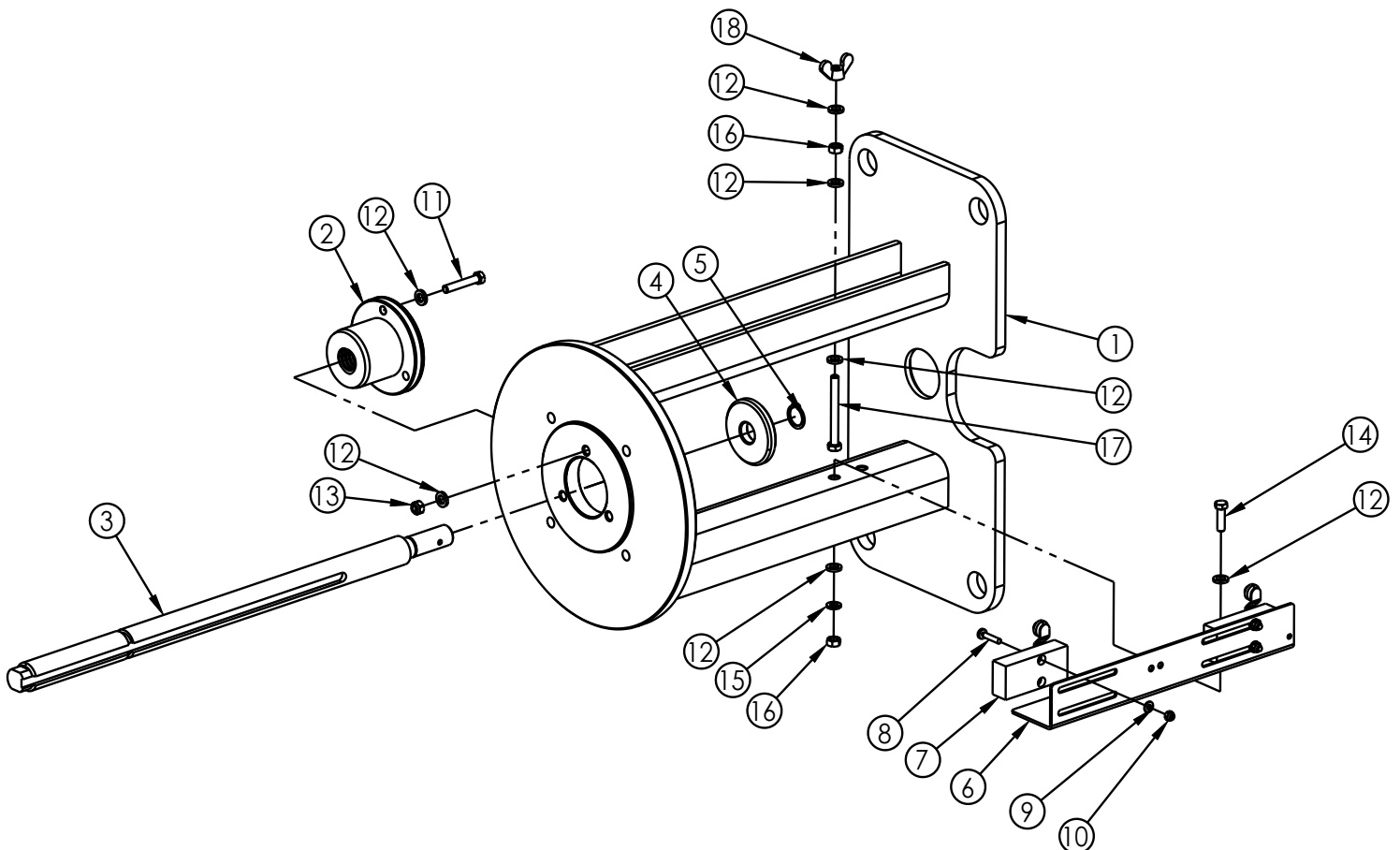

PARTS SCHEDULE AND DRAWING STANDARD SAF 4500

Section 3 - Scanner

No.	Description	Qty
1	NOZZLE SAF-4500 POM SCANNER	4
2	SUC SCANNER SHAFT SAF-4500	1
3	PIN 5X45 S/ST316	1
4	PLUG 8MM SAF POM F/SCANNER	1
5	SUCTION SCANNER SAF-4500 S/ST316	1

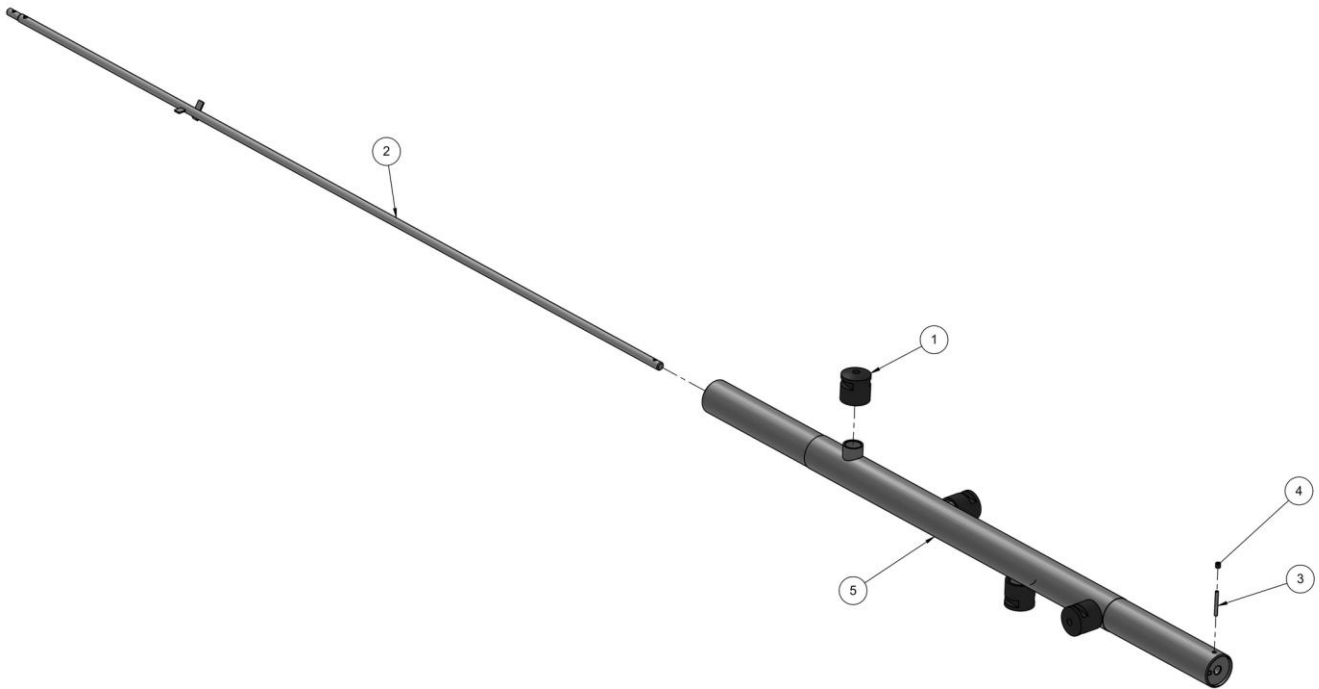

PARTS SCHEDULE AND DRAWING STANDARD SAF 4500

Section 3 SLN Scanner

No.	Description	Qty
1	SLN Suction Scanner Improved SAF-4500 Machined	1
2	Suction Scanner Shaft SAF-4500	1
3	PIN 5X45 S/ST316	1
4	PLUG 8MM SAF POM F/SCANNER	1
5	SLN Cap SAF-3000/45000	4
6	O-RING Seal 2-016 NBR	4
7	SLN Body SAF-3000/1500	4
8	SLN Seal 16mm	8
9	SLN Tightening Nut SAF-4500/3000	4
10	Spring Loaded Nozz. Spring SAF-3000/4500	4
11	SLN Spring Seat SAF-3000/4500	4

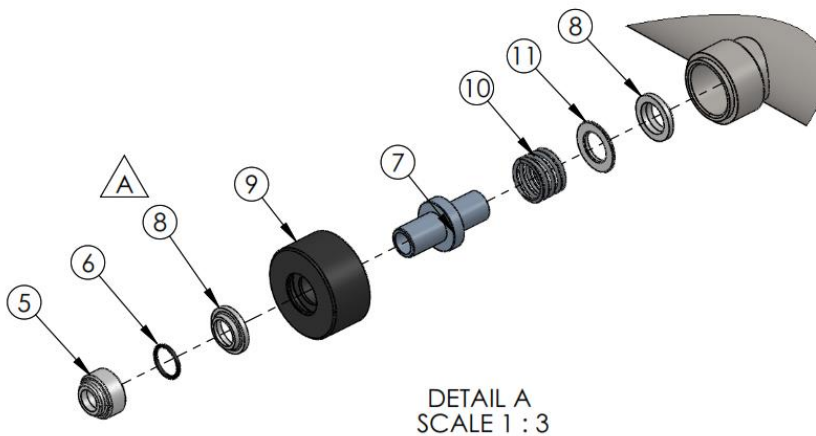
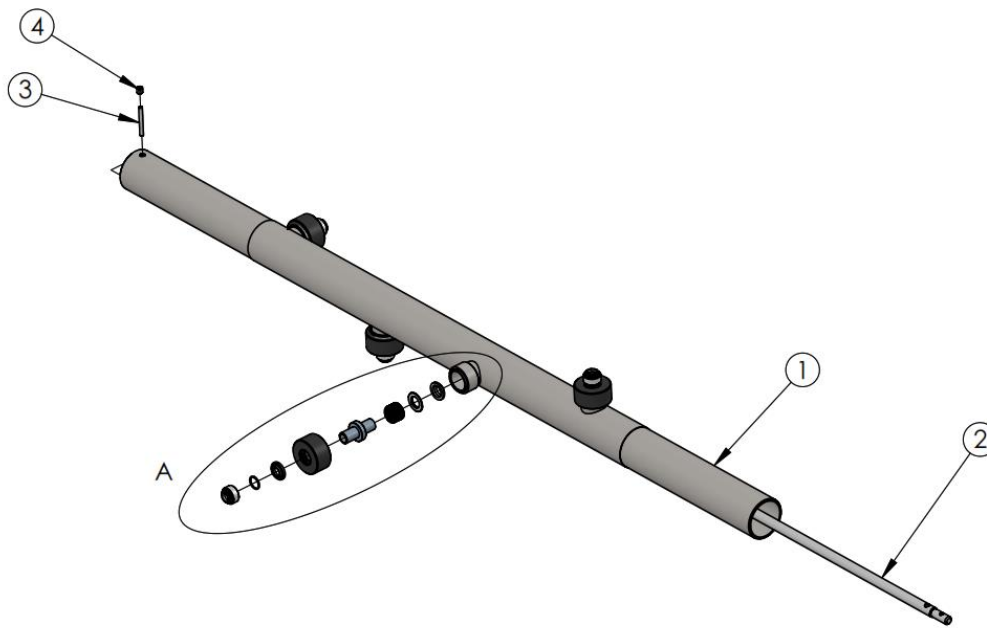

AMIAD LIMITED WARRANTY

1. This certificate applies to Amiad Water Systems Ltd. ("**Amiad**") products purchased by you (the "**Buyer**") from Amiad unless specifically agreed otherwise in writing by Amiad. This Warranty extends only to the original purchaser, and is not transferable to anyone who subsequently purchases, leases, or otherwise obtains the product from the original purchaser.
2. Amiad hereby warrants that the products are and will be free from defects in material and workmanship under normal use and service. Amiad warrants that it will correct manufacturing defects in the products, in accordance with the conditions set out in this Warranty.
3. This Warranty is enforceable for a period of 12 months after the date upon which the products were delivered (the "**Warranty Period**").
4. In the event that during the Warranty Period the Buyer discovers a defect in material and/or workmanship in any product or part (the "**Defective Product**"), it shall submit a written complaint to Amiad using Amiad's standard Buyer Complaint Form. For the receipt of the Buyer Complaint Form, the submission of the complaint or any questions please contact your service representative.
5. Upon written demand by Amiad the Buyer shall return the Defective Product - or a sample thereof - to Amiad, at Amiad's cost. If the Buyer ships any such Defective Product, Amiad suggests the Buyer package it securely and insure it for value, as Amiad assumes no liability for any loss or damage occurring during shipment. Provided however that in the event Amiad determines that this Warranty does not apply to such product, Buyer shall promptly reimburse Amiad for such cost (including freight and customs). Any returned product or part must be accompanied by the Warranty certificate and the purchase invoice. It is clarified that the Buyer may not return the Defective Product unless such return was coordinated and approved by Amiad in advance.
6. Amiad's obligation under this Warranty shall be limited to, at Amiad's option, the repair or exchange, free of charge, of the product or any part which may prove defective under normal use and service during the Warranty Period. The provision of a repair or replacement of a product during the Warranty Period will result in an extension of the Warranty Period by an additional period of 12 months, provided that the total accumulated Warranty Period shall in any event be no more than 18 months from the date upon which the products were delivered.
7. This Warranty is valid on the condition that the products are installed according to Amiad's instructions as expressed in Amiad's instruction manuals and according to the technical limitations as stipulated in Amiad's literature or as stated by a representative of Amiad.
8. This Warranty will not apply to damaged or defective products resulting from or related to:
 - (i) Fire, flood, power surges or failures or any other catastrophe and/or unforeseen occurrence, such as but not limited to those for which the Buyer is customarily insured for, or any force majeure events;
 - (ii) Fault, abuse or negligence of the Buyer;
 - (iii) Intake water not meeting the agreed standards, as set forth in a written document, approved by Amiad, or improper storage;
 - (iv) Improper or unauthorized use of the product or related parts by the Buyer, including Buyer's failure to operate the product in conformity with the recommendations and instructions of Amiad, as set forth in Amiad's manuals and other written materials, the operation of the product other than by a trained and qualified operator, or improper installation of the product by a third party not authorized by Amiad;
 - (v) Performance by the Buyer of maintenance or operation other than in conformity with the recommendations and instructions of Amiad, or other than in accordance with procedures defined in the literature supplied for products (including the timely replacement of requisite parts), and for services provided other than by a trained and qualified advanced operator; or
 - (vi) Any alteration, modification, foreign attachment to or repair of the products, other than by Amiad or its authorized technical representatives.
9. In no event shall Amiad be liable to the Buyer or any third party for any damages to property, or for any intangible or economic loss, including loss of profits, loss of customers or damage to reputation, for any damages, including indirect, special, consequential damages, or punitive damage arising out of or in connection with this Warranty, or arising out of or in connection with the product's performance or failure to perform, even if it has been advised of the possibility of such damages.
10. Amiad will be excused for failure to perform or for delay in performance hereunder if such failure or delay is due to causes beyond its reasonable control or force majeure preventing or hindering performance.
11. This Warranty set forth herein is the only contractual warranty given by Amiad and is provided in lieu of any other warranties created by any documentation, packaging or otherwise.
12. Amiad makes no warranty whatsoever in respect to accessories or parts not supplied by Amiad. In the event that Amiad is required to correct a Defective Product or product not covered by this Warranty, it will do so solely in consideration for additional fees.
13. The parties will actively endeavor to amicably settle any dispute arising between them. In the event that the parties are unable to reach an equitable settlement of such dispute, any claim or lawsuit related to the Warranty, its validity execution, its performance be brought before only the courts of Tel-Aviv, Israel. Israeli law will govern the Warranty, to the exclusion of any conflict



Amiad Water Systems Ltd. D.N. Galil Elyon 1, 1233500, Israel.

Tel: +972 4690 9500 | Fax: +972 48141159 | Email: info@amiad.com

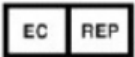

Obelis s.a. Bd Général Wahis 53, 1030 Brussels, Belgium.

Tel: +(32) 2732 5954 | Fax: +(32) 27326003 | Email: mail@obelis.net

EC Declaration http://amiad.com/pdf/certificates/MACHINERY_SAFETY.pdf