

AMIAD Water Systems LTD.

6" Filtomat MCFM 12000 C/ST Filter

Serial number:
Order Number:
Catalog Number:
Filtration Degree:
Tested By:

Installation, Operation and Maintenance Instructions

Ref. 6"-12,000/ 06.2020
Original Instructions



AMIAD Water Systems LTD. 6" Filtomat MCFM 12000 Filter

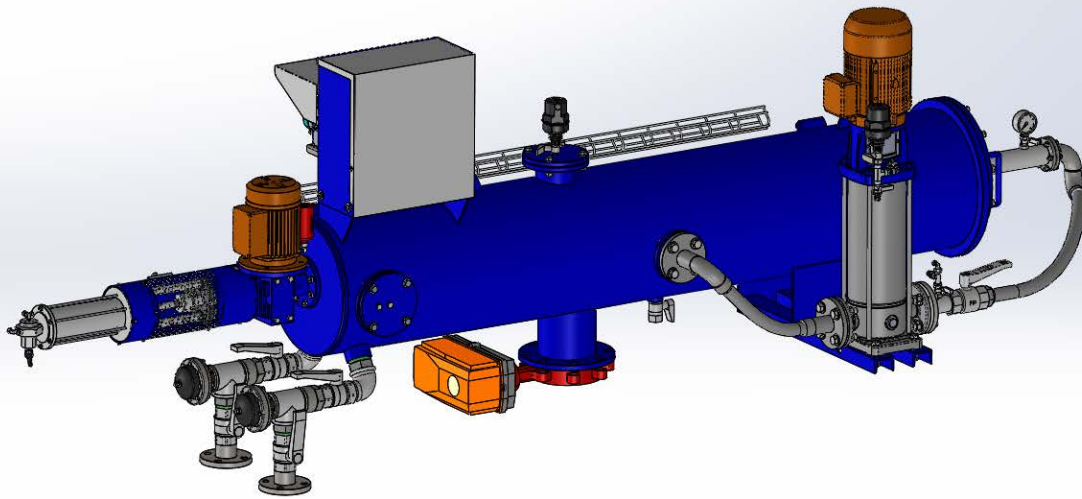

Disclaimer:

Copyright © 2018 Amiad Water Systems Ltd. All rights reserved.

The contents of this document, including without limitation all information and materials, images, illustrations, data, drawings, names and any other such materials that appear in this document are the sole property of Amiad Water Systems Ltd., including any intellectual property rights, whether registered or not, and all know-how contained or embodied therein. Amiad may alter, remove or change the Content without any further notice. You may not reproduce, copy, modify, create derivative works from, sell or participate in any sale of, or exploit in any way, in whole or in part, any of this document or its content.

The confidential nature of and/or privilege in the file enclosed is not waived or lost as a result of a mistake or error in this file. If you received this file in error, please notify Amiad immediately at info@amiad.com.

This document does not replace any certified drawing, procedure or information provided by Amiad in reference to a specific customer, site or project.

Amiad assumes that all users understand risks involved within this file and/or its attached materials. This document is given in good faith and is not intended to impose any obligation to Amiad. While every effort has been made to ensure the information in this manual is accurate and complete, we would appreciate if you can bring any errors or omissions to the knowledge of Amiad or consult Amiad experts or its authorized representatives if you have any questions.

Amiad Water Systems Ltd. D.N. Galil Elyon 1, 1233500, Israel Tel: 972 4 690 9500 | Fax: 972 4 814 1159 Email: info@amiad.com

TABLE OF CONTENTS

TECHNICAL SPECIFICATIONS	6
SAFETY INSTRUCTIONS	7
P&ID DRAWING	10
DESCRIPTION AND FILTER OPERATION.....	11
Filtering process	11
Self-cleaning process.....	11
Different modes of filtration	11
INSTALLATION.....	12
Installation instructions.....	12
Important notes on drain pipe configuration!!.....	12
PREVENTION OF REVERSE FLOW	13
Preventing reverse flow	13
Air entrapment.....	13
Preventing air entrapment.....	13
Technical solutions to remove trapped air.....	13
ELECTRIC WIRING.....	14
Electrical power source preparation	14
Control wiring.....	14
Air supply (Pneumatic control only).....	14
Hydraulic control	14
START-UP AND FIRST OPERATION	15
MAINTENANCE	16
Schedule of inspections and preventive maintenance and.....	16
Routine maintenance.....	16
Schedule maintenance.....	16
Dimensional Drawing.....	17
Parts Schedule - Section 1 Page 1	18
Parts Schedule - Section 1 Page 2.....	19
Parts Schedule - Section 1 Page 3.....	20
Parts Drawings - Section 1 page 1.....	21
Parts Drawings - Section 1 page 2.....	22
Parts Schedule - Section 2.....	23
Parts Drawings - Section 2	24
Parts Schedule - Section 3 page 1.....	25
Parts Schedule - Section 3 page 2.....	26
Parts Drawings - Section 3	27
LUBRICATION.....	28
OEM Maintenance	28
Troubleshooting maintenance	28

PRIMARY DISASSEMBLY INSTRUCTIONS..... 29

 Removing the piston (C) 29

 Removing the coarse screen (I), dirt collector (J), and Finescreen (K) 29

 For stainless steel coarse screens: 29

 Or - For plastic coarse screens:..... 29

 Finally 29

PRIMARY ASSEMBLY INSTRUCTIONS 30

 Insertion of dirt collector (J), fine screen (K), and coarsescreen (I)..... 30

 For Stainless steel coarse screens: 30

 Or - For plastic coarse screens:..... 30

 Continue with assembly (for both screens)..... 30

 Insertion of piston 30

PART 2 - MCFM PLC CONTROLLER 31

INTRODUCTION 37

GENERAL DESCRIPTION 37

OPERATOR TERMINAL 38

 Programmable Controller – PLC 38

 Selecting Program Modes..... 38

 Time Triggered Flush Mode 38

 Continuous Flush Mode..... 38

 Table 1 Program Sub Modes..... 39

 Selecting Sub-Mode Default Values 39

 Definitions of Time Triggered Sub-Modes 40

 Definitions of continuous flush sub-modes 42

 Program logic steps in continuous flush mode..... 43

PROGRAMMING General Operations..... 44

Amiad Limited Warranty 59

With any inquiry please quote the Filter Serial Number, located on the filter housing.

TECHNICAL SPECIFICATIONS

General

Flow rate range	150 m ³ /h		Consult supplier for optimum flow depending on filtration degree & water quality.
Min. working pressure	1 bar	14.1 PSI	
Max. working pressure	10 bar	150 psi	
Inlet/Outlet diameter	150mm,100mm	6",4"	AS 4087 PN16
Max. working temperature	65°C	150°F	
Weight (empty) range	465kg		

Flush data

Flushing valve	2 x 50mm	2 x 2"	
Flushing cycle time	Time triggered/DP /continuous flushing options		
Flow for flushing	15m ³ /h		

Control and electricity

Control voltage	24 V/DC
Electric motor	380V/1.1 Kw & 4 KW; 50 Hz
Rated operation Voltage	All standard 3 phase voltages acceptable.
Current consumption	Voltage and KW dependant

Construction materials

Filter Housing and Covers	ST/ST 316
Screens	Stainless Steel 316 wire cloth on plastic cylindrical body
Cleaning mechanism	Stainless Steel & Polypropylene
Flushing valve	ST/ST, Various
Seals	Natural Rubbers

Filter area

Screen type	12000	
Flat screen	7273cm ²	
4-Layer screen	12126cm ²	

Filtration degrees available

	Flat Screen									
micron	3000	1500	800	400	200	150	120	100	80	50
Mm	3.0	1.5	0.8	0.4	0.2	0.15	0.12	0.1	0.08	0.05

	4-Layer Screen												
micron	1500	800	400	200	150	130	100	80	50	40	30	25	15
Mm	1.5	0.8	0.4	0.2	0.15	0.13	0.1	0.08	0.05	0.04	0.03	0.025	0.015

SAFETY INSTRUCTIONS

General Safety Instructions

- Amiad filtration products always operate as components in a larger system. It is essential for the system designers, installers and operators to comply with all the relevant safety standards.
- Prior to installation, operation, maintenance or any other type of action carried out on the filter, read carefully the safety, installation and operation instructions.
- During installation, operation or maintenance of the filter all conventional safety instructions should be observed in order to avoid danger to the workers, the public or to property in the vicinity.
- Please note: The filter enters into a flushing mode automatically, without prior warning.
- No change or modification to the equipment is permitted without a written notification given in advance by the manufacturer or by its representative, on the manufacturer's behalf.
- Always observe standard safety instructions and good engineering practices whilst working in the filter's vicinity.
- Use the filter only for its intended use as designed by Amiad, any misuse of the filter may lead to undesired damage and may affect your warranty coverage. Please consult with Amiad prior to any non-regular use of this equipment.

Installation

General

- Install the filter according to the detailed Installation Instructions provided with the filter by the manufacturer and according to the description given in this manual.
- Make sure to leave enough clearance so as to enable easy access for future treatments and safe maintenance operations.
- The user should arrange suitable lighting at the area of the filter to enable good visibility and safe maintenance.
- The user should arrange suitable platforms, ladders and safety barriers to enable easy and safe access to the filter without climbing on pipes and other equipment. The user should verify that any platform, barrier, ladder or other such equipment is built, installed and used in accordance with the relevant local authorized standards.
- Check and re-tighten all bolts during commissioning and after the first week of operation.
- Use only appropriate standard tools and equipment operated by qualified operators when installing, operating and maintaining the filter.
- When installation is required in hazardous environment sites, underground or high above ground, make sure that the site design and the auxiliary equipment are appropriate and that installation procedures are carried out in accordance with the relevant standards and regulations.
- Ensure walking areas about the installation are slip free when wet.

Shipment and transporting

- Shipping and transporting the filter must be done in a safe and stable manner and in accordance with the relevant standards and regulations.
- For shipping, lifting and positioning the filter, use only approved lifting equipment and authorized employees and contractors.

Electricity

- Electric wiring should be performed by an authorized electrician only, using standardized and approved components.
- Install a **lockable** main power cut-off switch close to the control panel.
- If due to site constraints, the control panel is installed without a clear line-of sight of the filter, an additional **lockable** power disconnect cut-off switch should be installed near each filter unit.
- Installation of the filter should be performed so as to avoid direct water splashing on the electrical components or on the control panel.

Pneumatics

- Install a **lockable** main cut-off switch, **featured with a pressure release mechanism**, on the compressed air supply line close to the control panel.
- If the control panel is installed far away and there is no eye contact with the filter, a **lockable** compressed air cut-off switch, **featured with a pressure release mechanism**, should be installed near each filter unit.
- The user should make sure that the compressed air supplied to the filter never exceeds the maximum designated pressure for this filter. An air-pressure reduction valve should be installed on the compressed air supply line upstream of the filter's pneumatic inlet port.

Hydraulics

- Extra safety devices should be installed on hot water applications to avoid skin burn danger.
- The user should install a manual Water Cut-off Valve next to the filter's inlet port.
- In cases where the downstream piping network downstream of the filter is pressurized an additional manual Water Cut-off Valve should be installed next to the filter outlet port.
- The user should make sure that the system includes a Pressure Release / Drainage Valve to enable release of residual pressure prior to any maintenance procedure performed on the filter.
- The user should make sure that the filter is never exposed to water pressure exceeding the maximum designated pressure for this filter, if needed a Pressure Reduction Valve should be installed upstream of the filter's water inlet port.
- Please note that the maximum working pressure indicated at the filter's specifications table includes the pressure caused by fluid hammer and pressure surge effects.

Civil Engineering

- Make sure that the filter installation is done by Amiad qualified technicians.
- Make sure that any civil engineering work at the installation site such as construction, lifting, welding, etc. is done by qualified workers / technicians / contractors and in accordance with the relevant local standards.
- While using lifting equipment, make sure that the filter or the lifted part is chained securely and in a safe manner.
- Do not leave lifted equipment if there is no necessity. Avoid working below lifted equipment.
- Wear a safety helmet while using lifting equipment.
- Make sure that the flooring is sloped for drainage and to avoid accumulation of liquids.

Commissioning

- Read carefully the Commissioning and the First Start-up Operation instructions prior to any attempt to operate the filter.
- In order to achieve maximum performance and smooth operation of the filter it is crucial to perform the Startup and First Operation procedures exactly as described in this manual.
- Commissioning the filter should be done by an authorized Amiad technician, do not attempt to commission the filter unaccompanied since this may lead to undesired damage and may affect your warranty coverage.

Operation and Control

- Do not operate the filter before reading carefully and being familiar with its operation instructions.
- Observe the safety stickers on the filter and never perform any operation contradicting the instructions given.
- Never operate or use the filter for purposes other than its original design and operational envelope.

Maintenance

Before any maintenance or non-regular operation please read the following:

- Servicing the filter should be done only by technicians authorized by Amiad.
- Disconnect the filter from the power supply and lock the Main Power Switch.
- Disconnect the compressed air supply, release the residual pressure and lock the Pneumatics Main Valve.
- Disconnect the filter from the water system by closing and securing the Manual Inlet Valve. In cases where the downstream piping network is pressurized, close and secure the Manual Outlet Valve also.
- Release the residual water pressure by opening the Pressure Release / Drainage Valve.
- Empty the filter by opening the Drainage Valve.
- In hot water systems wait till the filter components cool off to a safe temperature.
- Place warning signs around the work area as required by the local standards and procedures.
- Inspect the filter's safety stickers and replace any damaged or faded sticker.

Mechanical

- When working on the filter use only appropriate standard tools.
- Always open and close valves slowly and gradually.
- Remove grease and fat material residues in order to avoid slipping.
- Before disconnecting the filter from the water supply, electricity and pneumatics and before releasing the filter's residual pressure do NOT:
 - loosen or unscrew bolts
 - remove any protection cover
 - open any service port flange
- Avoid splashing and water leakage so as to minimize slippage, electrification or damage to the equipment, caused by moisture.
- While using lifting equipment, make sure that the filter or the lifted part is chained securely and in a safe manner.
- Do not leave lifted equipment if there is no necessity. Avoid working below lifted equipment.
- Wear a safety helmet, goggles, gloves, and any other personal safety equipment required by the local standards and regulations.
- Human entry into a filter must be done in accordance with the relevant local safety instructions, standards and regulations for working in hazardous environment.
- Manual cleaning of filter media using high water pressure or steam should be performed in accordance with the cleaning system instructions, the local standards and regulations and without endangering the operator or the vicinity
- Manual cleaning of filter element using acid or other chemical agents should be performed in accordance with the relevant material safety instructions, the local standards and regulations and without endangering the operator or his vicinity.

Before returning to regular operation

- Re-assemble any protection covers or protection mechanisms removed during service or maintenance operations.
- Make sure that all the tools, ladders, lifting devices, etc. used during the maintenance procedures are taken away from the filter area and stored
- In order to return the filter to regular operation, follow the First Start-up Operation instructions as detailed in your user manual.
- For filters used in potable water systems it is required to disinfect the filter according to the local water authority standards and regulations before putting it back to service.

P&ID DRAWING

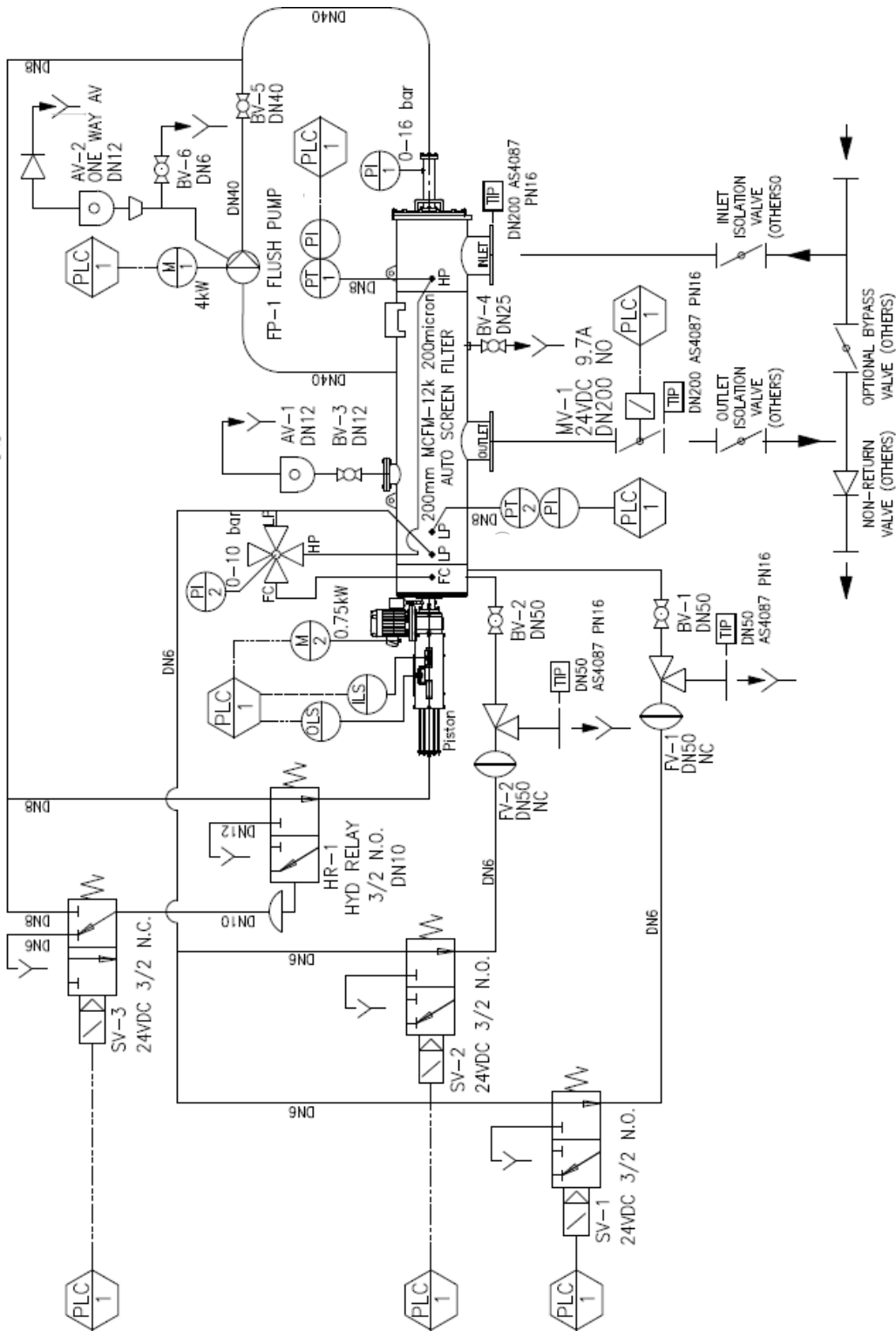

DESCRIPTION AND FILTER OPERATION

Filtering process

The MCFM is an automatic, continuous, self-cleaning filter for high flow rates and high dirt loads driven by electrical control combined with pneumatic or hydraulic operation. The MCFM is designed to work with various types of screens in filtration degrees from 3000 to 15 micron, and is available in 4", 6", 8", 10" and 12" inlet/outlet diameters.

Self-cleaning process

The PLC controls the self-cleaning modes required according to type of dirt and dirt loads or other application variables. The MCFM will start the self-cleaning process when the pressure differential across the screen reaches a pre-set value or a pre-determined lapse of time. The MCFM can also run in a continuous mode.

The water flows through inlet, passing through the coarse screen. The dirt is stopped on the inner face of the cylindrical fine screen. The filtered water flows to the outlet.

A central dirt collector is equipped with suction nozzles and injection nozzles.

A back-flush stream removes the dirt from the inner cylindrical fine screen face through the back-flush nozzles to the drain chamber and via the flush valve. The injection stream passes through the injection nozzles and cleans the back side of the fine screen.

While back-flushing, the collector's movement is both rotational as well as longitudinal. The combination of these movements ensures full coverage of the screen area by suction and injection streams.

Rotational motion is achieved by an electrical drive unit. Longitudinal motion of the piston is achieved in one of two ways:

- Pneumatically (pneumatic piston)
- Hydraulically (hydraulic piston—optional)

Different modes of filtration

The filtration system may be found in one of the following modes:

- **Triggered mode:** In this mode, the back-flush cycle is operated at pre-determined time intervals or differential pressure inputs.
- **Continuous mode:** In this mode, the back-flush cycle operates continuously.

The Triggered and Continuous Modes are divided into sub-modes:

- **Flush sub-mode:** The flush valve, pump and piston are active. The MCFM is filtering and self-cleaning at the same time.
- **Rest sub-mode:** No self-cleaning activity. The MCFM is only filtering the fluid. This sub-mode is only available in the triggered mode.
- **Super-flush sub-mode:** This sub-mode of flushing is used to create a greater suction pressure than that in the triggered and continuous modes, in order to remove stubborn particles from the fine screen which cannot be removed by the normal flush sub-mode suction pressure. In this sub-mode, back-flush suction pressure is increased for a short period of time.
- **Reduced flow sub-mode:** In this sub-mode, the MCFM outlet valve will close. This will increase the filter internal pressure which will create a higher suction pressure. This sub-mode occurs only under high differential pressure input.

INSTALLATION

Installation instructions

1. Select a convenient location for the installation of the filter where operation and maintenance will be optimum. A lifting auxiliary is recommended for installation.
2. Ensure that the distance between inlet and outlet flanges complies with the data sheet.
3. Ensure that the diameters and flange dimensions of the inlet and outlet pipes comply with the datasheet.
4. If possible, prior to installing the filter, flush the main line at the connection point thoroughly, to remove large objects that may damage the filter's internal mechanism.
5. Prepare appropriate hardware to join the inlet and outlet flanges to the filter inlet and outlet flanges (bolts, nuts and gaskets).
6. Install the filter horizontally. Please note that a minimum clearance as shown on the installation drawing is required in order to allow disassembly of the unit.
7. Ensure the direction of flow according to the arrows marked on the filter housing.
8. The user should arrange suitable lighting at the area of the filter to enable good visibility and safe maintenance.
9. The user should arrange suitable platforms and safety barriers to enable easy access to the filter without climbing on pipes and other equipment.
10. Ensure adequate size drain piping is available for connecting two BSP/NPT 2" drain valves for continuous flush and super-flush.

Important notes on drain pipe configuration!!

- Connect the drain piping system to allow free flow.
- Depending on application, a minimum differential pressure between 0.2 bar and 0.6 bar should be maintained between filter inlet and drain port. Installation of pump in the drain pipe should be considered, in case of back pressure in drain system.

PREVENTION OF REVERSE FLOW

Fine screen collapse is caused by hydraulic pressure acting externally upon the screen. The hydraulic back pressure results from a differential pressure across the screen, where the external pressure is greater than the internal pressure.

The process conditions leading to this screen failure have been identified through failure studies of actual installed filters.

The major process conditions are:

- Process media backflow through the screen.
- Air entrapment in the fine screen compartment of the filter house.

The four-layer screen is very sensitive to back pressure; small differential back pressure acting upon a blocked screen shall cause collapse.

Preventing reverse flow

Reverse flow can be avoided in these ways:

1. Install a check (non-return) valve downstream of the filter. The check valve shall be of the quick acting type, and the disc's return should be spring loaded. The valve manufacturer's installation recommendations must be conformed, to prevent any back flow through the valve.
2. Avoid additional pressure sources between the filter and the process. When this cannot be avoided, isolate the filter before introducing these pressure sources.
3. Close the filter manual outlet valve, and then the inlet valve before stopping the process pump. Start the pump before opening the filter inlet and outlet valves.
4. Avoid situations of automatic process pump starts and stops where back flow may result.

Air entrapment

Air entrapment must be minimized in the fine screen chamber. This is not only to protect the screen from collapse, but to allow the entire fine screen to be submerged in the media and participate in the filtration. This is more important in low pressure applications.

When air entrapment is present, any sudden release of hydraulic pressure shall allow the air pocket to expand and push media in a backflow direction through the fine screen.

Preventing air entrapment

Air entrapment damage can be avoided in these and other ways:

1. Vent entrapped air from the fine screen chamber.
2. Do not isolate the filter from the pressure source until the flush valves are closed.
3. Do not open the flush valves after the filter has been isolated from the pressure source and until the filter has been depressurized.
4. To depressurize, and when opening the filter for maintenance, release the internal pressure slowly. This can be achieved by a ¼" valve.
5. When draining the filter, ensure that the filter has been depressurized first.

Technical solutions to remove trapped air

The MCFM filter housings are provided with a connection port for an optional air release valve.

ELECTRIC WIRING

If the control board is not mounted on the MCFM, install the control board in a dry and protected place.

Electrical power source preparation

1. Prepare a three-phase (R, S, T, N, G) power supply. The power source parameters are determined by the local main power network voltage and pump size.
2. Connect the motors to the suitable terminals on the control board. Use cables of adequate cross section approved by local regulations.

Control wiring

1. Connect the proximity switch wires to the correct terminals.
2. Check that all factory wiring is intact and not damaged.

Air supply (Pneumatic control only)

1. Connect a 6 bar air supply to the manifold supplied on the MCFM.
2. Select an industrial air mist lubricator for proper solenoid functioning.
3. Fill the absorber tank and piston with an ethylene glycol/water mixture or hydraulic oil. Fillings should be to the overflow level of the side port on the tank with the piston at switch 2.

Hydraulic control

Installation connections for Hydraulic controls are subject to special configurations which are provided by the factory per application.

START-UP AND FIRST OPERATION

Prior to operation, completely understand controller settings. Make sure the electric wiring is correct, according to the enclosed drawings.

1. Open the continuous flush valve completely.
2. Open the booster pump vent valve to bleed air.
3. Apply water to the filter. If inlet valve is installed, open valve.
4. Open all manual valves on the outlet tubing system of the booster pump.
5. Check the system for leakage.
6. Turn on the booster pump by pressing the pump switch at overload protection switch box.
7. Verify that the pump is turning in the proper direction according to the arrow marked on the pumpbody.
8. Verify that the outlet valve is open.
9. At this time, air is bled through the booster pump vent valve. When the vent valve water flow is free of air bubbles, close vent valve.
10. Turn on the gear unit by pressing the gear unit switch at overload protection switch box.
11. Check that the piston is turning in the appropriate direction (CCW—viewed from piston free end).
12. Check that the drain collector and suction/injection nozzles are turning in the appropriate direction (CW). The rotation direction may be viewed through a sight glass, when supplied.
13. Visually check that the piston is operating normally and reaches its maximum forward and rearpositions.
14. Adjust continuous flush valve by carefully closing valve manually to obtain 0.5 bar differential pressure between the outlet chamber and the drain chamber. At this state (0.5 bar), the drain valve is properly adjusted. Do not disturb valve after adjustment.
15. Run forced super-flush. Adjust manual super-flush valve for 1 bar differential pressure between the outlet chamber and the drain chamber.

MAINTENANCE

Schedule of inspections and preventive maintenance.

The following schedule of inspections and preventive maintenance is based on continuous filtration duty, and therefore should be used as a guideline only.

It is recommended having a periodic inspection to see if there is no increase in grease leakage. This indicates wear of the bearings and they need to be replaced in order to prevent damage to the Rod Connection Type6 (Part No46)

The user should compile his or her own schedule of maintenance and inspection based on experience gained from using the filter and learning its operation in service.

* However the minimum schedule for replacement of certain parts should not exceed 6 months.

Routine maintenance

- Make sure that the automatic lubrication unit is operating and contains enough grease.
- Visually inspect all the external parts for leakage, excess corrosion, tightness of fasteners, etc. Take corrective actions if required.
- Check valve settings and pressures before and during the flush. Pressure points are:
 - ❖ Before fine screen/coarse screen
 - ❖ After fine screen
 - ❖ Drain chamber
 - ❖ Injection pressure after booster pump
- Check conditions of process water, air supply.
- Check integrity of the process and air supply equipment.
- Clean any spill on or around the filter.

Schedule maintenance

- Open the filter and inspect all internal parts for leakage, excess corrosion, wear, tightness of fasteners. Take corrective action if required.
- Remove and manually clean the coarse screen.
- Remove, clean and inspect the fine screen. Inspection is visual. Determine that the fine screen is not blocked nor torn or otherwise damaged.
- Check fine-screen O-rings.
- Replace all dynamic U-rings, bearings, wipers, (Every 6 Months Min.)
 - ❖ Peek Bearing.
 - ❖ U-ring.
 - ❖ Wiper Seal.
 - ❖ Delrin bearings.
- Check all dynamic parts.
 - ❖ Pin Shaft Anti Rotation.
 - ❖ Rod Connection Type6.
 - ❖ Rod Drive.
- Replace worn dynamic parts if required.
- Check dirt collector nozzles for excessive wear.
Take corrective action if required.
- Check integrity of pressure hoses and tubes.
- Check internal filter housing paint. Repair damaged areas.
- After assembly carry out a routine maintenance program

Dimensional Drawing

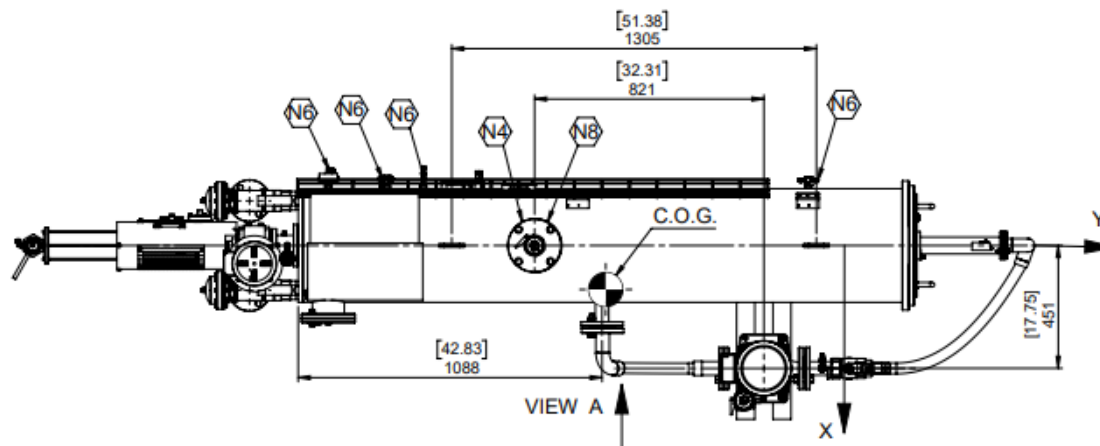
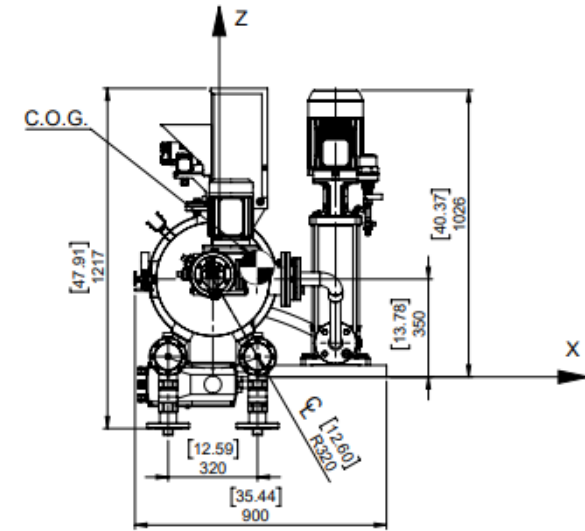
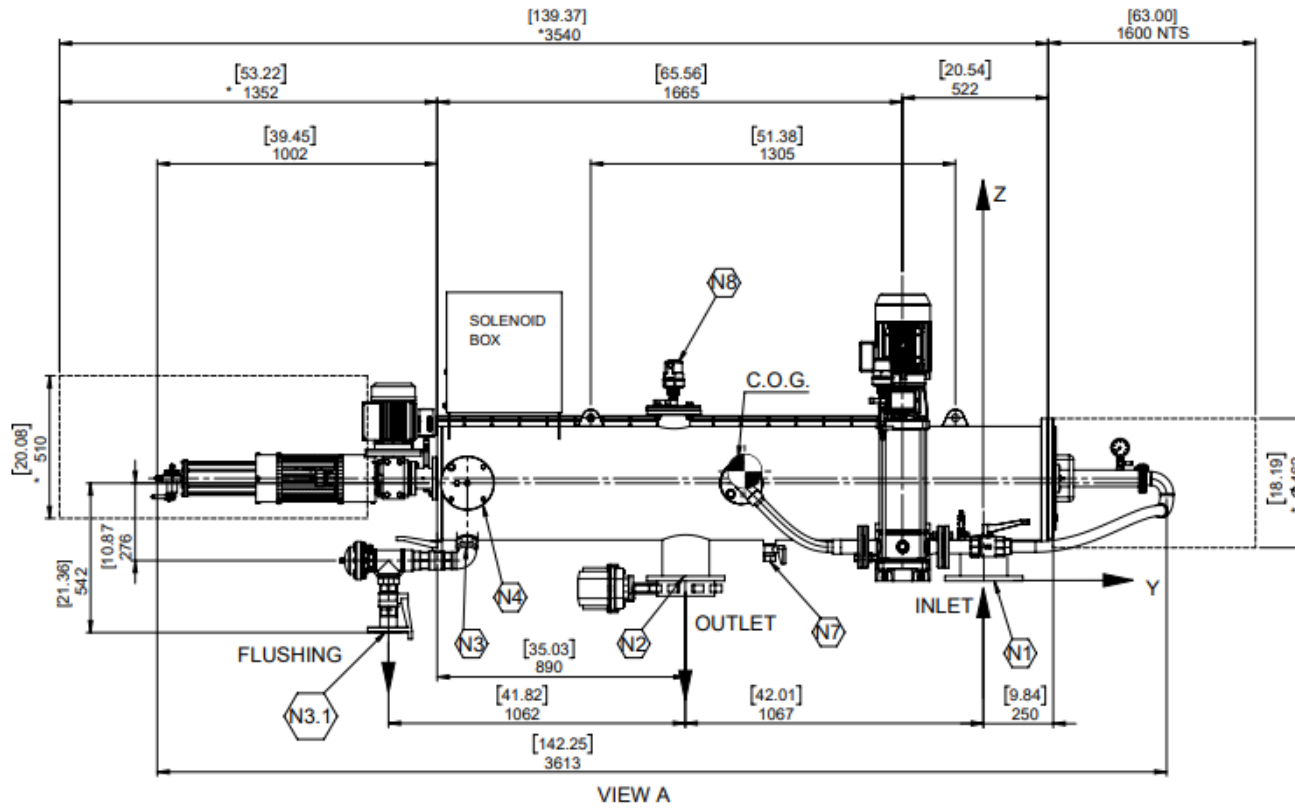

PARTS SCHEDULE

ITEM NO.	CAT. NO.	DESCRIPTION	QTY.	MATERIAL
1	710105-005943	MCFM-12000 HOUSING 6" BSTE PKPK 5010 ST.37-2 POLYESTER	1	ST 37-2
2	750103-001719	SPOOL MANIFOLD 2" AS4087 S/ST316L 10 BAR	2	S/ST 316
3	710103-003369	GUIDE PIPE MCFM OKOLON F/DIRT COLLECTOR	1	Akulon
4	710103-003147	RING RETAINING MCFM-12000 NBR F/DIRT COLLECTOR	1	Rubber
5	700190-002802	D.C. ASSY (16 NOZZ) MCFM 12 A 316	1	VARIOUS
6	760104-000118	STUD BOLT 3/8" UNC 43MM S/ST316	12	S/ST 316
7	770102-000147	PARKER O-RING 2-335 NBR 70 SHORE	1	NBR
8	760102-000116	HEX NUT 3/8"UNC S/ST316 B18.2.2	8	S/ST 316
9	710103-003203	MCFM EXTENSION ROD S/ST316L PASSIVATION	1	S/ST 316
10	710103-003037	PIN 95MM MCFM-8000 S/ST316 PISTON SHAFT CONNECTOR	1	S/ST 316
11	760105-000025	PIN COTTER 2.5X25MM S/ST316 DIN94	2	S/ST 316
12	770104-000153	SHAPED SEAL COVER MX14-16(P)(SP.C 30)NAT	1	NBR
13	760104-000127	Stud Bolt 1/2"UNCx50 Long 20/12 S/ST316	12	S/ST 316L
14	760103-000115	Flat Washer 1/2" B18.22.1 St.St 316	68	S/ST 316L
15	760102-000117	HEX NUT 1/2"UNC S/ST316 B18.2.2	28	S/ST 316
16	710105-001966	MCFM-XXXX EXTENSION S/ST316 ELECTROPOLISH	1	S/ST 316L
17	770102-000145	PARKER O-RING 2-331 NBR 70 SHORE NO FLASH	1	NBR
18	700190-002848	GUIDE D.C. SHAFT (A) S/ST+OKOLON ASSY	1	VARIOUS
19	710103-003172	COVER 1" MCFM-12000 S/ST316 GUIDE SHAFT	1	S/ST 316
20	770105-000053	U-CUP EPDM OD50 ID34 H9.5 80SH YELLOW.D	1	EPDM
21	710105-000357	M104/6LP COVER SERVICE PKPK 5010 ST.37-2 POLYESTER PRESSURE GAUGE COATED	1	ST.37-2
22	770102-000167	PARKER O-RING 2-430 NBR 70 SHORE	2	NBR
23	760101-000574	HEX BOLT PARTIAL THRD 1/2"UNCX2" 316	8	S/ST 316
24	710105-000352	M104/6LP COVER SERVICE PKPK 5010 ST.37-2 POLYESTER FOR SERVICE	1	ST.37-2
25	780101-000861	ELBOW STREET 2" BSP M/BSP F S/ST316	2	S/ST 316
26	780101-000818	NIPPLE 2"X85MM BSPT M S/ST316	6	S/ST 316
27	760103-000113	Flat Washer 5/16"x1mm Thick	24	S/ST 316
28	700101-000753	COARSE SCREEN PVC MCFM12000	1	PVC
29	720401-000945	CENTRIFUGAL PUMP LOWARA 10SV11F040T 4.0KW 6M3H 120M 415V S/ST316 3PH 50HZ 2900RPM 1.5"X1.5" PN10/16 WEG MOTOR	1	S/ST 316
30	900103-000018	NAMEPLATE ENGLISH S/ST316 FILTOMAT SELF-CLEANING FILTERS CE 125X114X1MM	1	S/ST 316
31	760105-000036	RIVET BLIND 3X6 DIN 7337 S/ST316	4	S/ST 316
32	710105-005868	MCFM BRACKET PKPK 5010 ST.37-2 POLYESTER	1	ST 37-2
33	760101-000572	HEX BOLT FULL TH 1/2"UNCX1" S/ST316	4	S/St-316
34	710103-010188	BRACKET F/SOLENOID CABINET MCFM S/ST304 F/BURKERT	1	S/ST 316
35	720103-000704	SOLENOID+LED BURKERT 0330 3WAY 3/2 NC 8W 24VDC 50/60HZ 1/4" 2MM S/ST NPT NBR SEALS IP65	1	S/ST 316

ITEM NO.	CAT. NO.	DESCRIPTION	QTY.	MATERIAL
36	720103-000703	SOLENOID+LED BURKERT 0330 3WAY 3/2 NO 8W 24VDC 50/60HZ 1/4" 2MM S/ST NPT NBR SEALS 0-16BAR IP65	2	S/ST 316
37	720501-001180	ELBOW CONNECTOR 1/4"M X8MM NPT S/ST316 AIGNEP	17	S/ST 316
38	760101-000841	HEX BOLT FULL THRD M5 10MM S/ST316 DIN933	2	S/ST 316
39	760103-000093	FLAT WASHER M5 DIN125 S/ST304	4	S/ST 304
40	730108-000110	AIR RELEASE VALVE A.R.I SEGEV S-050-P 1/2" BSPT NYLON3 16BAR	2	PP
41	720290-000137	S/ST SURFACE FINNISH CODE 55X50	1	S/ST 316
42	780101-000840	PLUG 1" BSP S/ST316	1	S/ST 316
43	720301-000036	PRESSURE GAUGE 0-16 BAR/PSI NUOVA FIMA S/ST316 1/4" BSP BOTTOM 2" W/GLYCERINE	1	S/ST 316
44	760101-000676	PHIL FLAT MCHINE SCRWB 1/4"UNCX1/2" 316	2	S/ST 316
45	760103-000005	FLAT WASHER 1/4" SPECIAL S/ST304	4	S/ST 304
46	770103-000039	FLAT SEAL 1 1/2" ISO PN16 KLINGERIT FILTOMAT	3	Polyurethane
47	770102-000118	PARKER O-RING 2-228 NBR 70 SHORE	1	NBR
48	760101-000454	HEX BOLT FULL THRD M8 40MM S/ST316 DIN933	6	S/ST 316
49	720501-000455	PLUG 1/4"M BSP S/ST316	4	S/ST 316
50	760103-000092	FLAT WASHER M4 DIN125 S/ST304	12	S/ST 304
51	760101-000510	PHILLIPS PAN MACHINE SCREW M4X15 304	12	S/ST 304
52	720302-000282	PRESSURE TRANSMITTER SIEMENS P310 S/ST316 1/2" BSP 0.16-10 BAR 0-16BAR 4-20MA IP66	2	VARIOUS
53	760101-000173	HEX BOLT FULL TH M10X30 S/ST304 DIN933	9	S/ST 304
54	760103-000028	Flat Washer M10 DIN125 S/ST304	18	S/ST 304
55	760102-000011	HEX NUT M10 S/ST304 DIN934	9	S/ST 304
56	900101-001444	WOOD+TRI-WALL CARTON PALLET+COVER+BRIDGE H.S.C FOR 4"-8" MCFM-12000	1	Various
57	700190-005781	PISTON 95MM TYPE 8 MCFM 8000/12000 (10 NOZZ/16 NOZZ)	1	VARIOUS
58	700190-005789	VALVE QUICK ASSY 2"NO 90 B/B OIL HP S/ST316 NIT.R	2	VARIOUS
59	730104-000263	2-WAY BALL VALVE 2" F/F S/ST316 MANUAL	4	S/ST 316
60	730104-000213	2-WAY BALL VALVE 1/2" MBSPT/FBSPT S/ST316 MANUAL	2	S/ST 316L
61	720501-000467	ADAPTOR 3/8"M X1/8"F BSP S/ST316	1	S/ST 316
62	720501-000272	L-CONNECTOR 1/4"F X1/4"M NPT S/ST316 HAM-LET	2	S/ST 316
63	720501-000307	T-CONNECTOR 1/4"FX1/4"F X1/4"F NPT S/ST316 HAM-LET	1	S/ST316
64	730104-000193	2-WAY BALL VALVE 1/4" MBSPT/FBSPT S/ST316 MANUAL TAIWAN VALVE	3	S/ST 316
65	720501-000468	ADAPTOR 1/2"F X1/4"M BSP S/ST316	1	S/ST 316L
66	710103-003317	FITTING ADAPTOR 1 1/2" MCFM S/ST316L BSP KIT HOSE	1	S/ST 316
67	730104-000249	2-WAY BALL VALVE 1 1/2" F/F S/ST316 MANUAL	1	S/ST 316
68	790207-000130	1 1/2" S/ST316 PRESSURE HOSE BSP 790MM	1	S/ST316
69	710105-000587	M300-3000A COVER PKPK 5010 ST.37-2 POLYESTER	1	ST.37-2
70	760103-000117	Flat Washer 5/8" B18.22.1	32	S/ST 316

ITEM NO.	CAT. NO.	DESCRIPTION	QTY.	MATERIAL
71	760101-000585	HEX BOLT PARTIAL TH 5/8"UNCX2 3/4" 316	12	S/ST 316
72	760102-000118	HEX NUT 5/8"UNC S/ST316 B18.2.2	12	S/ST 316
73	760101-000576	Hex Bolt Partial Thread 1/2"UNCX2 3/4" 316	4	S/ST 316
74	720501-001178	STRAIGHT CONNECTOR 1/4"M X8MM NPT S/ST316 AIGNEP	5	S/ST 316
75	760104-000153	STUD BOLT 5/16" UNC 37MM S/ST316	6	S/ST 316
76	760102-000115	HEX NUT 5/16"UNC S/ST316 B18.2.2	6	S/ST 316
77	790207-000134	1 1/2" S/ST316L PRESSURE HOSE ISO16 850MM	1	S/ST 316L
78	720501-000316	T-CONNECTOR 1/4"FX1/4"F X1/4"M NPT S/ST316 HAM-LET	1	S/ST 316L
79	710103-003098	PRESSURE POINT 1/4" MCFM-8000 S/ST303 BSP	2	S/ST 303
80	730104-000289	5-WAY BALL VALVE 1/8" NPT MINI S/ST316 MANUAL SWAGELOK	1	S/ST 316
81	720501-000262	NIPPLE 1/4"M X1/8"M NPT S/ST316 HAM-LET	2	S/ST 316
82	720301-000033	PRESSURE GAUGE 0-10 BAR/PSI NUOVA FIMA S/ST316 1/4" NPT BOTTOM 2.5" W/GLYCERINE	1	S/ST 316
83	720501-001181	ELBOW CONNECTOR 1/8"M X8MM NPT S/ST316 AIGNEP	2	S/ST 316
84	720501-001179	STRAIGHT CONNECTOR 1/8"M X8MM NPT S/ST316 AIGNEP	3	S/ST 316
85	730108-000112	3-WAY MINI 3X1/8" NPT S/ST316 CONTROL	1	S/ST 316
86	720501-000461	L-CONNECTOR 3/8"M X12MM NPT S/ST316	1	S/ST316
87	760102-000201	NYLON INSERT LOCKNUT 1/2"UNC S/ST316 B18.16	4	S/ST 316
88	760102-000086	HEX NUT M8 S/ST316 DIN934	4	S/ST 316
89	720501-000252	NIPPLE 1/4"M X1/4"M NPT S/ST316 HAM-LET	1	S/ST 316
90	710105-005702	MCFM COVER S/ST316 ELECTROPOLISH F/CONTROL BRACKET	1	S/ST 316
91	720501-000248	L-CONNECTOR 1/8"M X8MM NPT S/ST316 HAM-LET	1	S/ST 316
92	720501-000414	BUSHING 3/8"M X1/4"F NPT S/ST316 HAM-LET	1	S/ST 316
93	720502-000021	CONTROL TUBE 12MM LDPE 200MM LONG	1	S/ST 316
94	710105-005869	MCFM SCREEN S/ST316 ELECTROPOLISH	1	S/ST
95	760103-000096	FLAT WASHER M8 DIN125 S/ST316	8	S/ST 316
96	760101-000609	HEX BLT FUL TH M8 20MM S/ST316 DIN933	4	S/ST 316
97	730104-000233	2-WAY BALL VALVE 1" MBSPT/FBSPT S/ST316 MANUAL	1	S/ST 316
98	700101-001095	FLAT SCREEN PVC+S/ST316L 12000SQ.CM 100MIC MCFMXXXX	1	PVS+S/ST
99	720501-000458	BUSHING 1/2"M X1/4"F BSP S/ST316	2	S/ST 316
100	720501-001180	ELBOW CONNECTOR 1/4"M X8MM NPT S/ST316 AIGNEP	17	S/ST 316
101	730105-000971	DN150 ELECTRIC BUTTERFLY VALVE GRL AS4087LUGGED BLUE F02 250 LV F WP CI BODY,316 DISC,431 STEM,EPDM KEYSTONE	1	Varrious

Explosion Drawings

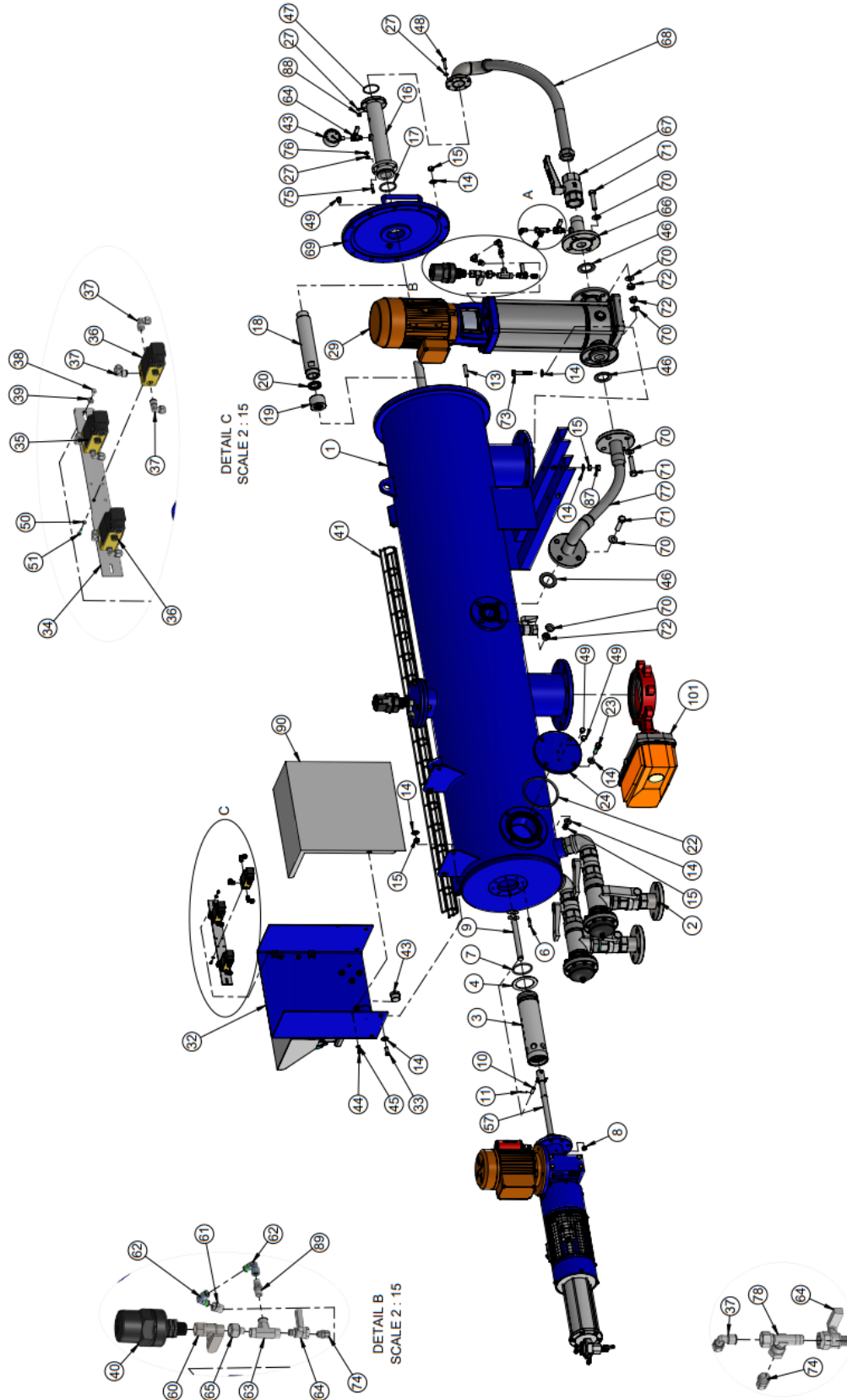

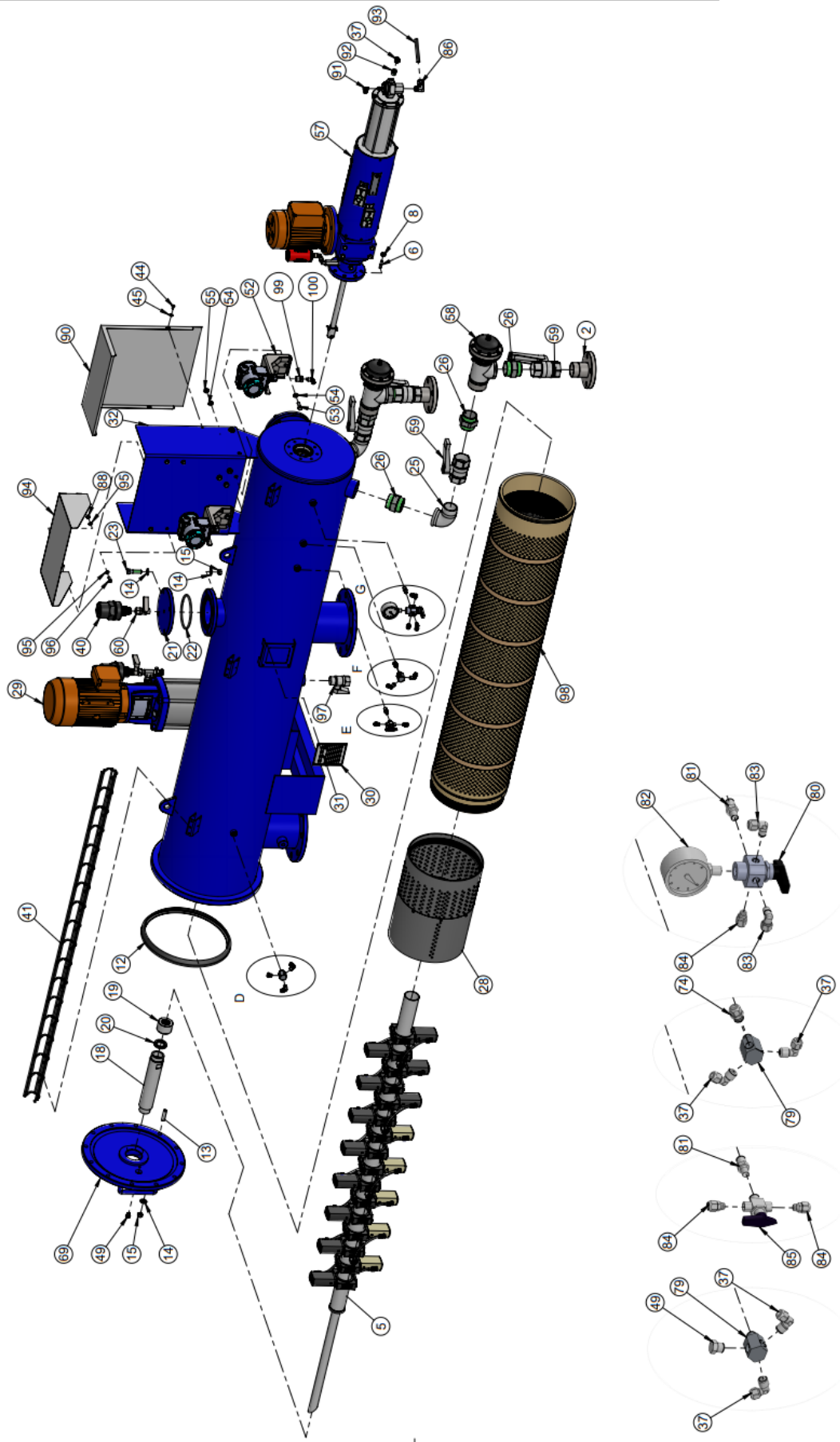

LUBRICATION

- Piston gear unit

All units are supplied with oil filling, oil level and drain plugs.

To fill the gear with oil remove the oil level and oil overflow plugs and fill through oil filling hole until lubricant overflows the oil level plug hole.

Oil recommendation (0.85 liter capacity)

Esso	Spartan EP 320	
Mobil Oil Co.	Mobil gear 632	
Shell	Omala oil 320	
Delek	Delphen EP 320	Moly Gear oil 300
Sonol	Compound 60	
Paz	Pazamal 320	Optimol Optigear 5180

The units are supplied without oil. First oil change is recommended after 200 hours. Subsequent oil changes should be after 2000-3000 hours according to working condition. Oil draining must be carried out while the oil is still warm, and after flushing the unit. For long period storage, fill the unit completely with oil.

- Change piston automatic greaser as suggested by the greaser manufacturer.
- Grease O-rings and U-rings before re-using.
- Add fluid to the absorber tank as required.
- Add hydraulic oil to mist lubricators as required.

OEM Maintenance

OEM items include booster pump, various solenoid valves, automatic outlet valve, Delta P switches, various electronic items in the controller, and electric motors. Maintenance of OEM items should be in accordance with OEM supplier recommendations.

Troubleshooting maintenance

Troubleshooting maintenance solutions are referred to in the PLC Controller Operation Manual.

PRIMARY DISASSEMBLY INSTRUCTIONS

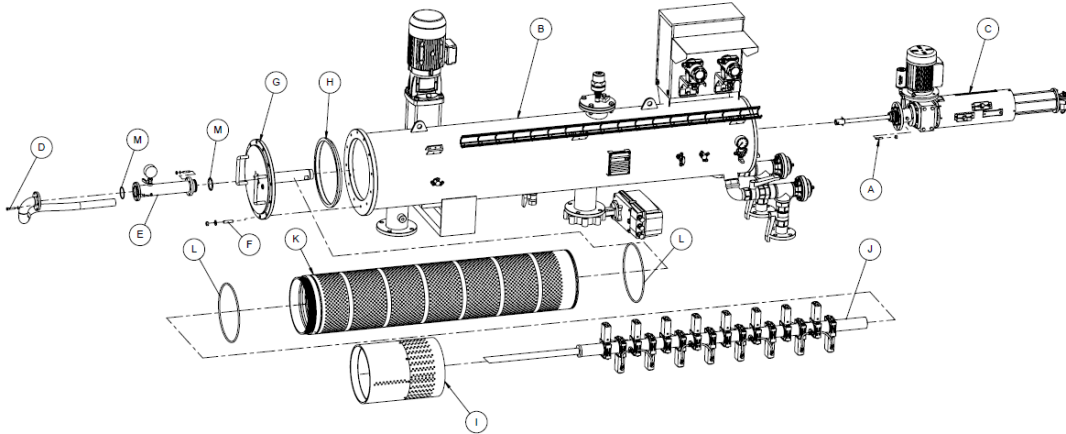

Opening the filter and disassembling its inner components is necessary for changing screens, periodic maintenance and repairs. Prior to opening the filter it is recommended to operate a flushing cycle.

Prior to disassembling the filter:

1. Isolate, depressurize, and drain the filter
2. Isolate the main electrical power to the filter controls and motors.
3. Isolate the pneumatic air supply to the filter and release pressure.

Removing the piston (C)

1. Disconnect all electrical and control wires
2. Disconnect pneumatic or hydraulic tubing.
3. Unscrew nuts (A).
4. Pull piston straight and out of the filter house (B).

Removing the coarse screen (I), dirt collector (J), and Fine screen (K)

1. Unscrew bolts (D), washers, and nuts (E) and disconnect the booster pump discharge hose from the service cover assembly (G).
2. Unscrew nuts (F) and pull service cover assembly (G) straight out of the filter house (B).

For stainless steel coarse screens:

3. Pull the stainless steel coarse screen (I) straight out of the filter house (B).
4. Using a fine screen push/pull tool, pull the fine screen (K) along with the dirt collector (J) straight out of the filter house.

Or - For plastic coarse screens:

4. Using a fine screen push/pull tool, pull the plastic coarse screen (I) screwed to the plastic fine screen (K), and along with the dirt collector (J) straight out of the filter house.

Finally

5. Slide the dirt collector (J) out of the fine screen (K), taking care not to damage the fine screen mesh.

PRIMARY ASSEMBLY INSTRUCTIONS

Insertion of dirt collector (J), fine screen (K), and coarse screen (I)

1. Slide the dirt collector (J) into the fine screen (K), taking care not to damage the fine screen mesh.
2. Inspect and grease the fine screen O-rings (L).
3. Using a fine screen push/pull tool, push the fine screen (K) along with the dirt collector (J) straight into the filter house (B).
4. The dirt collector body pipe must go into the bearing at the far end of the filter.
5. The fine screen O-rings must sit on the intended filter house seats.

For Stainless steel coarse screens:

6. Insert the stainless steel coarse screen (I) into the filter house (B) and onto the fine screen end. The coarse screen should extend approximately 8 mm beyond the filter house.

Or - For plastic coarse screens:

6. Insert the plastic coarse screen (I) into the filter house (B) and engage its threaded end with the threaded end of the fine screen.
7. Screw the coarse screen (I) onto the fine screen and adjust it to extend approximately 8 mm beyond the filter house.

Continue with assembly (for both screens)

1. Inspect the cover seal (H) and push the service cover assembly (G) straight on to the filter house, whilst inserting the dirt collector hollow shaft into the guide of the service cover assembly.
2. Screw the nuts (F) on the filter house stud bolts and tighten.
3. Connect the booster pump discharge hose to the service cover assembly (G). Use O-ring (M).
4. Screw bolts (D), washers and nuts (E), and tighten.

Insertion of piston

1. Inspect and grease O-ring seals that seal the piston to the filter house.
2. Insert the piston straight into the filter house (B)
3. Screw nuts (A) and tighten.
4. Connect pneumatic or hydraulic tubing.
5. Connect all electrical and control wires.
6. Connect electrical power supply.
7. Check that the rotation of the electric motor is in the correct direction.

After assembly, re-commission the filter.

Amiad Limited Warranty

1. This certificate applies to Amiad Water Systems Ltd. ("**Amiad**") products purchased by you (the "**Buyer**") from Amiad unless specifically agreed otherwise in writing by Amiad. This Warranty extends only to the original purchaser, and is not transferable to anyone who subsequently purchases, leases, or otherwise obtains the product from the original purchaser.
2. Amiad hereby warrants that the products are and will be free from defects in material and workmanship under normal use and service. Amiad warrants that it will correct manufacturing defects in the products, in accordance with the conditions set out in this Warranty.
3. This Warranty is enforceable for a period of 12 months after the date upon which the products were delivered (the "**Warranty Period**").
4. In the event that during the Warranty Period the Buyer discovers a defect in material and/or workmanship in any product or part (the "**Defective Product**"), it shall submit a written complaint to Amiad using Amiad's standard Buyer Complaint Form. For the receipt of the Buyer Complaint Form, the submission of the complaint or any questions please contact your service representative.
5. Upon written demand by Amiad the Buyer shall return the Defective Product - or a sample thereof - to Amiad, at Amiad's cost. If the Buyer ships any such Defective Product, Amiad suggests the Buyer package it securely and insure it for value, as Amiad assumes no liability for any loss or damage occurring during shipment. Provided however that in the event Amiad determines that this Warranty does not apply to such product, Buyer shall promptly reimburse Amiad for such cost (including freight and customs). Any returned product or part must be accompanied by the Warranty certificate and the purchase invoice. It is clarified that the Buyer may not return the Defective Product unless such return was coordinated and approved by Amiad in advance.
6. Amiad's obligation under this Warranty shall be limited to, at Amiad's option, the repair or exchange, free of charge, of the product or any part which may prove defective under normal use and service during the Warranty Period. The provision of a repair or replacement of a product during the Warranty Period will result in an extension of the Warranty Period by an additional period of 12 months, provided that the total accumulated Warranty Period shall in any event be no more than 18 months from the date upon which the products were delivered.
7. This Warranty is valid on the condition that the products are installed according to Amiad's instructions as expressed in Amiad's instruction manuals and according to the technical limitations as stipulated in Amiad's literature or as stated by a representative of Amiad.
8. This Warranty will not apply to damaged or defective products resulting from or related to:
 - (i) Fire, flood, power surges or failures or any other catastrophe and/or unforeseen occurrence, such as but not limited to those for which the Buyer is customarily insured for, or any force majeure events;
 - (ii) Fault, abuse or negligence of the Buyer;
 - (iii) Intake water not meeting the agreed standards, as set forth in a written document, approved by Amiad, or improper storage;
 - (iv) Improper or unauthorized use of the product or related parts by the Buyer, including Buyer's failure to operate the product in conformity with the recommendations and instructions of Amiad, as set forth in Amiad's manuals and other written materials, the operation of the product other than by a trained and qualified operator, or improper installation of the product by a third party not authorized by Amiad;
 - (v) Performance by the Buyer of maintenance or operation other than in conformity with the recommendations and instructions of Amiad, or other than in accordance with procedures defined in the literature supplied for products (including the timely replacement of requisite parts), and for services provided other than by a trained and qualified advanced operator; or
 - (vi) Any alteration, modification, foreign attachment to or repair of the products, other than by Amiad or its authorized technical representatives.
9. In no event shall Amiad be liable to the Buyer or any third party for any damages to property, or for any intangible or economic loss, including loss of profits, loss of customers or damage to reputation, for any damages, including indirect, special, consequential damages, or punitive damage arising out of or in connection with this Warranty, or arising out of or in connection with the product's performance or failure to perform, even if it has been advised of the possibility of such damages.
10. Amiad will be excused for failure to perform or for delay in performance hereunder if such failure or delay is due to causes beyond its reasonable control or force majeure preventing or hindering performance.
11. This Warranty set forth herein is the only contractual warranty given by Amiad and is provided in lieu of any other warranties created by any documentation, packaging or otherwise.
12. Amiad makes no warranty whatsoever in respect to accessories or parts not supplied by Amiad. In the event that Amiad is required to correct a Defective Product or product not covered by this Warranty, it will do so solely in consideration for additional fees.
13. The parties will actively endeavor to amicably settle any dispute arising between them. In the event that the parties are unable to reach an equitable settlement of such dispute, any claim or lawsuit related to the Warranty, its validity execution, its performance be brought before only the courts of Tel-Aviv, Israel. Israeli law will govern the Warranty, to the exclusion of any conflict of law rules.



Manufacturer

Amiad Water Systems Ltd. D.N. Galil Elyon 1, 1233500, Israel.
Tel: +972 4690 9500 | Fax: +972 48141159 | Email: info@amiad.com

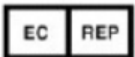

European Authorised Representative for CE

Obelis s.a. Bd Général Wahis 53, 1030 Brussels, Belgium.
Tel: +(32) 2732 5954 | Fax: +(32) 27326003 | Email: mail@obelis.net

EC Declaration <https://www.amiad.com/certificatesDownload.asp>

