



Backflow Prevention

350 Series DCV

32-50mm

Installation, Testing & Maintenance Instructions

INSTALLATION INSTRUCTIONS

CAUTION: Installation of Backflow Preventers must be performed by qualified, licenced personnel. The installer should be sure the proper device has been selected for the particular installation. Faulty installation could result in an improperly functioning device.

ZURN WILKINS Model 350 Double Check Valve assemblies are for use on water lines where a health hazard does not exist in the event of a backflow situation.

Damage to the device could result wherever water hammer and/or water thermal expansion could create excessive line pressure. Where this could occur, shock arresters, check valves and/or pressure relief valves should be installed downstream of the device.

If installation is in a pit or vault, the Backflow Preventer must never be submerged in water because this could cause a cross-connection. Make sure that the pit or vault always remains dry by providing ample drainage.

1. Before installing a Model 350 Backflow Preventer, flush the line thoroughly to remove all debris, chips and other foreign matter. If required, a strainer should be placed upstream of the Backflow Preventer. **CAUTION:** Do not use a strainer in seldom used emergency waterlines such as fire lines.
2. Provide adequate space around the installed unit so that the test cocks will be accessible for testing and servicing.
3. Install valve at least 305mm above surrounding flood level.
4. Always consult local codes for installation methods, approvals and guidance.

PLACING THE MODEL 350 IN SERVICE

1. Start with both shut-off valves closed. Slowly open the inlet shut-off valve until the backflow preventer is completely pressurised.
2. When the unit has been pressurised, vent any trapped air by slightly opening each of the three test cocks.
3. Slowly open the downstream shut-off valve. The Model 350 Double Check Valve assembly is now in service.
4. After the Model 350 has been properly installed, test the device (see "TEST PROCEDURES"). If the device fails the test, remove the first and second check valves and thoroughly flush the device. Clean rubber and seats of all debris and place unit back in service.

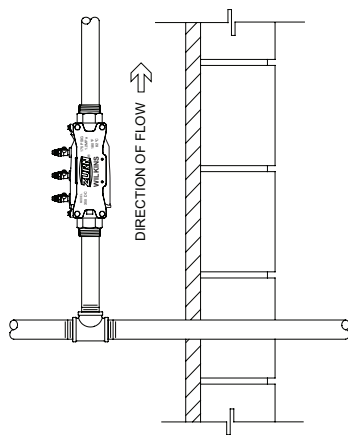

VERTICAL INSTALLATION

Vertical installation is acceptable in applications where inlet and outlet piping are flowing vertically upwards. All the basic installation instructions apply to such installations. Consult asset owner for approval status.

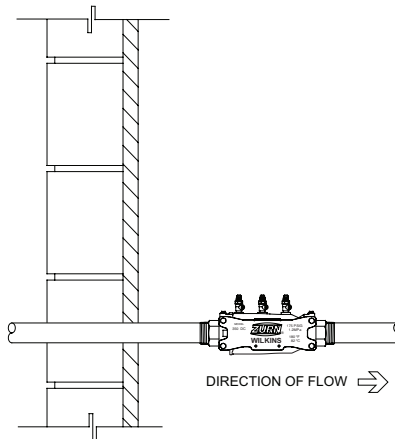

INDOOR INSTALLATION

Indoor installation is preferred in areas that are subject to freezing conditions. All the basic installation instructions apply to such installations.

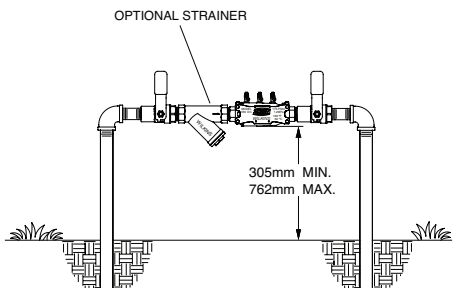
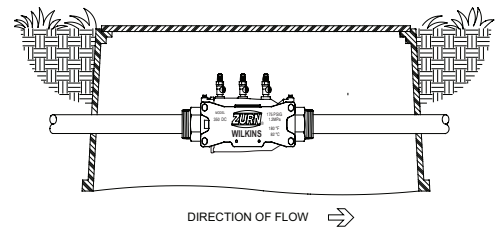

OUTDOOR INSTALLATION

The Model 350 Backflow Preventer may be installed outdoors only if the device is protected against freezing conditions. Exposure to freezing conditions will result in improper function or damage to the device. The installation location must be kept above 0°C. All the basic installation instructions apply.

Testing Procedures

MODEL 350 DOUBLE CHECK VALVE ASSEMBLY

Equipment Required: Differential pressure gauge test kit.

TEST NO. 1 - TIGHTNESS OF #1 CHECK VALVE

REQUIREMENT:

The static pressure drop across check valve #1 shall be at least 7 kPa. If test cock #3 is not at the highest point of the check valve body, then a vertical tube must be installed on test cock #3 so that it rises to the top of the check valve body.

PROCEDURE:

1. Slowly open all 3 test cocks to remove any foreign material and attach fittings.
2. Attach hose from the high side of the test kit to the #1 test cock.
3. Open test cock #1 and bleed all air from the hose and gauge by opening the high side bleed needle valve. Close high side bleed needle valve. Close #2 shut-off valve then close the #1 shut-off valve.
4. Hold gauge at same level as test cock #2. Slowly open test cock #2. Record the static pressure drop across check valve #1 after gauge reading stabilises and water stops running out of test cock #2.
5. Close all test cocks, open shut-off valve #1 and remove test equipment.

TEST NO. 2 - TIGHTNESS OF #2 CHECK VALVE

REQUIREMENT:

The static pressure drop across check valve #2 shall be at least 7 kPa.

PROCEDURE:

1. Attach hose from the high side of the test kit to the #2 test cock.
2. Open test cock #2 and bleed all air from the hose and gauge by opening the high side bleed needle valve. Close high side bleed needle valve. Close #2 shut-off valve.
3. Hold gauge at same level as test cock #3. Slowly open test cock #3. Record the static pressure drop across check valve #3 after gauge reading stabilises and water stops running out of test cock #3.
4. Close all test cocks, slowly open shut-off valve #1 & #2 and remove test equipment.

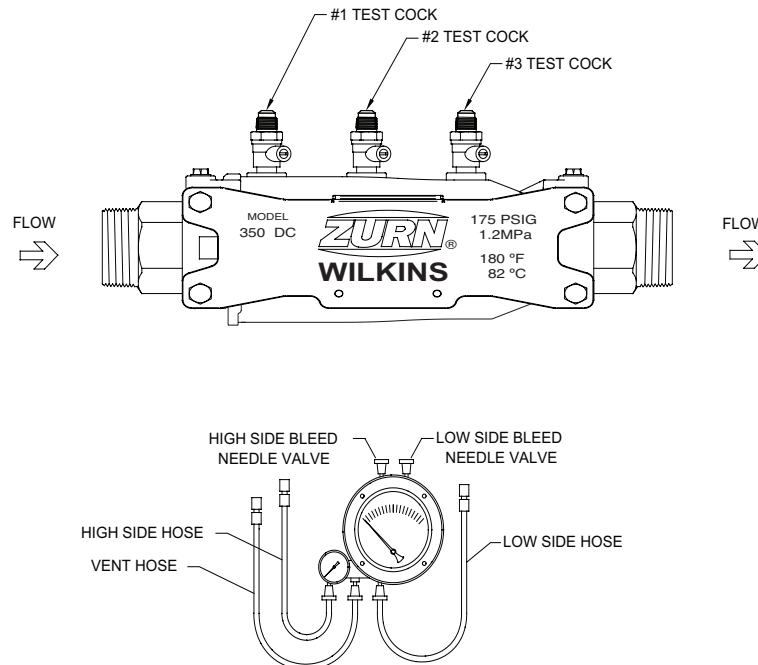

Please note all installation and testing procedures listed are intended as a guide only. Installation and testing should be in accordance to local standards and plumbing codes.

Maintenance Instructions

All Model 350 Double Check Valve Backflow Preventers must be inspected and maintained by licensed personnel at least once a year or more frequently as specified by local codes. Replacement of worn or damaged parts must only be made with genuine "ZURN WILKINS" parts.

GENERAL MAINTENANCE

1. Clean all parts thoroughly with water after disassembly.
2. Carefully inspect rubber seal rings and o-rings for damage.
3. Test unit after reassembly for proper operation (refer to "TESTING PROCEDURES").

SERVICING CHECK VALVES

1. Close inlet and outlet shut-off valves.
2. Open No. #1, #2 and #3 test cocks to release pressure from valve.
3. Unscrew the 4 bolts (1/4-20 UNC Hex Flange) holding the housing in place. Lift housing up to remove.
4. Twist and remove sleeve from body. Using finger or blunt object, push in outlet end of body, both checks should slide out the body inlet. A short object like a socket can be placed on a flat surface. Place body over object so it pushes into valve outlet and push down on body.
5. Twist spring retainers counter-clockwise to remove from seats and access poppets.
6. Inspect the rubber seal ring for cuts or embedded debris. To remove seal ring, remove screw and seal ring retainer. If the reverse side of the seal ring is unused, it is possible to invert the seal ring. This will be considered a temporary solution to fixing a fouled check and should be replaced with a new seal ring as soon as possible.
7. Inspect seat surface for nicks or dings and replace if necessary. Use fingernail to check for dings. Re-grease seat o-rings.
8. Inspect seat o-ring sealing areas in body and wipe clean.
9. Reverse the above procedures to reinstall check valve assembly. Drop #2 check assembly in body. Then drop #1 check assembly in and turn until #1 spring retainer lines up with #2 seat. Then push both assemblies into body. Insert sleeve against checks. (Place sleeve down against flat surface and push on body with rocking motion.)
10. Lightly grease face of o-rings on housing and reinstall into body following the above procedures in reverse order. Rock body side to side to help o-rings slide in. If it does not drop in completely, do not use screws to force it. An overly greased o-ring might slide out of groove at top of ball valve. Use a screw driver to push o-ring back in groove, then push body down in.

Note: When installing housing, match slight taper on the outlet of the housing with corresponding taper in body.

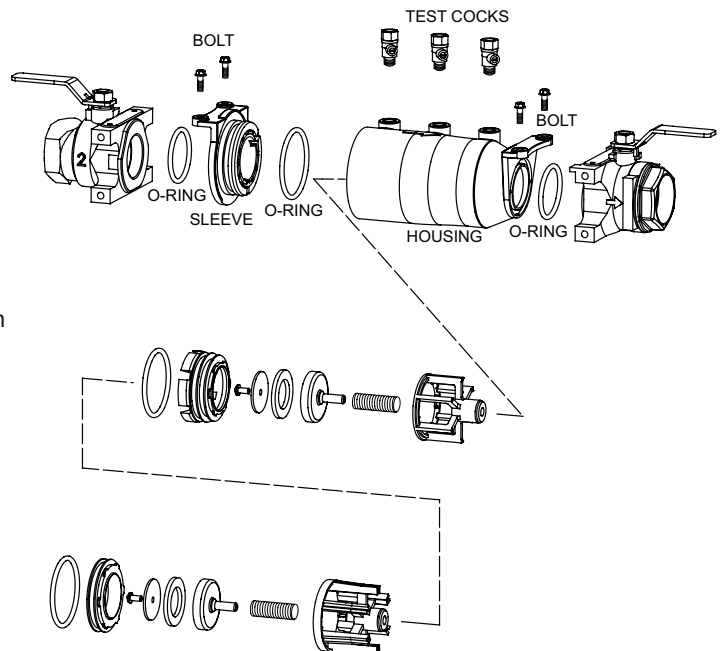
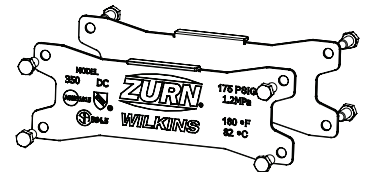
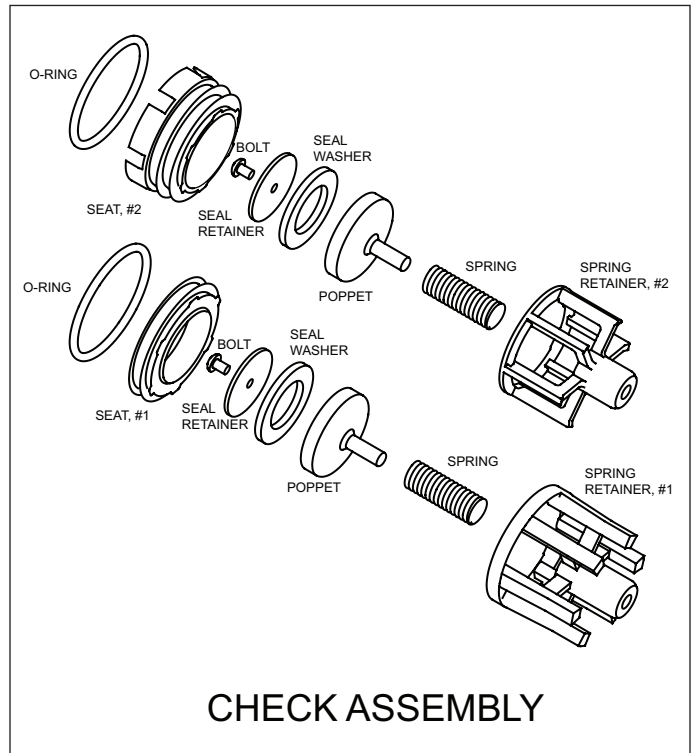

Troubleshooting

PROBLEM

POSSIBLE CAUSES

CORRECTIVE ACTION

1. LEAKING CHECK VALVES

1. Debris on seat or seal ring
2. Damaged seat
3. Damaged seal ring
4. Damaged check o-ring

1. Clean seat and seal ring area
2. Replace seat
3. Replace poppet
4. Replace check o-ring

2. LOW OR NO FLOW

1. Device installed backwards
2. Shut-off valves or valve upstream may not be fully open
3. Low supply pressure

Performance Characteristics

Flow Characteristics

MODEL 350 32-50mm (STANDARD & METRIC)

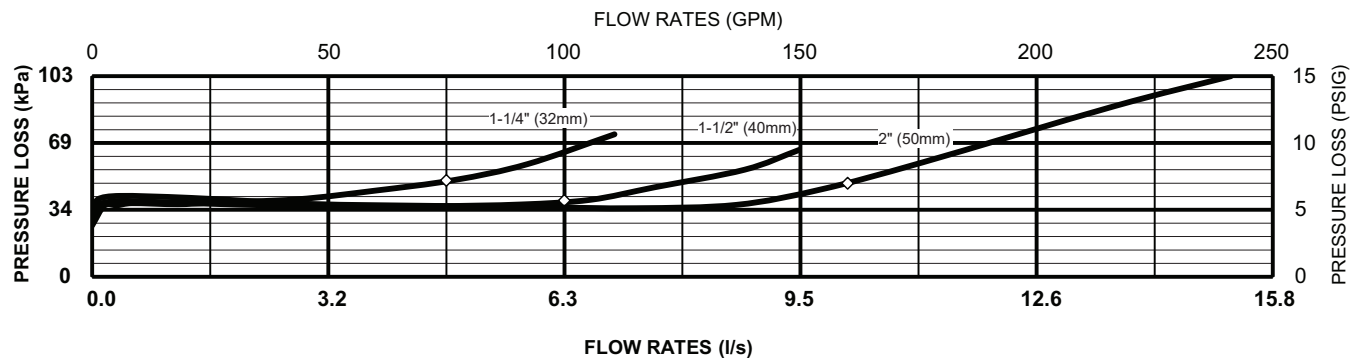

◇ Rated Flow (Established by approval agencies)

Capacity through Schedule 40 Pipe (l/s)

Pipe size (mm)	1.5 (m/s)	2.3 (m/s)	3.0 (m/s)	4.6 (m/s)
15	0.3	0.4	0.6	0.9
20	0.5	0.8	1.1	1.6
25	0.8	1.3	1.7	2.5
32	1.5	2.2	3.0	4.4
40	2.0	3.0	4.0	6.0
50	3.3	4.9	6.6	10.5

SPECIFICATIONS

Maximum working water pressure: 1200 kPa
 Maximum working water temperature: 82°C
 Hydrostatic test pressure: 2400 kPa
 End connections: ISO 7.1 R Tapered Pipe Thread

Proper performance is dependent upon licenced, qualified personnel performing regular, periodic testing according to ZURN WILKINS' specifications and prevailing governmental and industry standards and codes and upon following these installation instructions. Failure to do so releases ZURN WILKINS of any liability that it might otherwise have with respect to that device. Such failure could also result in an improperly functioning device.