

# AMIAD Automatic Filters

## "ABF-6000" FILTERS Automatic Brush Filters 8" - 14"

Serial number:	_____
Order number:	_____
Catalog number:	_____
Filtration degree:	_____
Tested by:	_____

### Installation, Operation and Maintenance Instructions



910101-000103 / 08.2019

# AMIAD Automatic Filters

## ABF-6000 FILTERS Automatic Brush Filters 8" - 14"



**Disclaimer:**

Copyright © 2017 Amiad Water Systems Ltd. All rights reserved.

The contents of this document, including without limitation all information and materials, images, illustrations, data, drawings, names and any other such materials that appear in this document are the sole property of Amiad Water Systems Ltd. ("Amiad"), including any intellectual property rights, whether registered or not, and all know-how contained or embodied therein (together the "Content"). Amiad may alter, remove or change the Content without any further notice. You may not reproduce, copy, modify, create derivative works from, sell or participate in any sale of, or exploit in any way, in whole or in part, any of this document or its Content.

The confidential nature of and/or privilege in the file enclosed is not waived or lost as a result of a mistake or error in this file. If you received this file in error, please notify Amiad immediately at [info@amiad.com](mailto:info@amiad.com).

This document does not replace any certified drawing, procedure or information provided by Amiad in reference to a specific customer, site or project.

Amiad assumes that all users understand risks involved within this file and/or its attached materials. This document is given in good faith and is not intended to impose any obligation to Amiad. While every effort has been made to ensure the information in this manual is accurate and complete, we would appreciate if you can bring any errors or omissions to the knowledge of Amiad or consult Amiad experts or its authorized representatives if you have any questions.

Amiad Water Systems Ltd. D.N. Galil Elyon 1, 1233500, Israel Tel: 972 4 690 9500 | Fax: 972 4 814 1159 Email: [info@amiad.com](mailto:info@amiad.com)

## TABLE OF CONTENTS

Technical specifications .....	4
Safety instructions .....	5
Dimensional and recommended installation drawing .....	8
Introduction .....	9
Installation and start-up instructions.....	10
Electrical control system description .....	11
Disassembling the filter .....	12
Reassembling the filter .....	12
Maintenance .....	13
Troubleshooting .....	14
Parts schedule.....	15
Parts drawing (View #1).....	16
Parts drawing (View #2).....	17
Parts drawing (View #3).....	18
Limited Warranty .....	19

With any inquiry please quote Filter Serial Number, located on the filter nameplate.

## SPECIFICATIONS

### General

Maximum flow rate	700m <sup>3</sup> /h; 3100USgpm	Consult manufacturer for optimum flow depending on filtration degree & water quality.
Min. working pressure	1bar; 15psi	Or lower if pressure is increased for flushing
Max. working pressure	10bar; 150psi	16 bar (240 psi) upon request
Filter area	6000cm <sup>2</sup> ; 630in <sup>2</sup>	
Inlet/Outlet diameter	200, 250, 300 & 350mm 8", 10", 12" and 14"	Flange standards as per request.
Filter housing diameter	400mm; 16"	
Max. working temperature	60°C ; 140°F	
Weight (empty)	200 mm = 213 kg 250 mm = 228 kg 300 mm = 237 kg 350 mm = 260 kg	8" = 470 lb. 10" = 503 lb. 12" = 523 lb. 14" = 573 lb.
Type of screen	800 - 3500 micron	Perforated screen
	200 - 800 micron	Wedgewire screen

### Flush data

Exhaust valve	50mm; 2"	or 80mm (3") if pressure lower than 2.5 bar
Flushing cycle time	15 seconds	
Wasted water per cycle	200 liter; 53USgal	at 4bar (60psi)
Minimum flow for flushing	50m <sup>3</sup> /h; 220USgpm	

### Control and electricity

Electric motor	3/4 HP / 14 Output R.P.M
Rated operation voltage	3 phase, 380V 50 Hz, or 220/440V 60 Hz
Upon request	24V DC / 12V DC
Control voltage	24V AC (24V DC upon request)

### Construction materials

Filter housing and lid	Carbon Steel 37-2 (Stainless Steel available on request)
Screen	Stainless Steel 316L
Cleaning mechanism	Stainless Steel 316, PVC and Delarin
Exhaust valve	Epoxy-Coated, Cast Iron
Seals	Nitrile rubber, Natural rubber, Teflon
Control system	Brass, Stainless Steel, Engineering plastic, Polyethylene

### Filtration degrees available

	Perforated Screen				Wedgewire Screen			
Micron	3500	2500	1500	800	800	500	300	200
mm	3.5	2.5	1.5	0.8	0.8	0.5	0.3	0.2

For special applications, also available 130 micron

## SAFETY INSTRUCTIONS

### General Safety Instructions

- Amiad filtration products always operate as components in a larger system. It is essential for the system designers, installers and operators to comply with all the relevant safety standards.
- Prior to installation, operation, maintenance or any other type of action carried out on the filter, read carefully the safety, installation and operation instructions.
- During installation, operation or maintenance of the filter all conventional safety instructions should be observed in order to avoid danger to the workers, the public or to property in the vicinity.
- Please note: The filter enters into a flushing mode automatically, without prior warning.
- No change or modification to the equipment is permitted without a written notification given in advance by the manufacturer or by its representative, on the manufacturer's behalf.
- Always observe standard safety instructions and good engineering practices whilst working in the filter's vicinity.
- Use the filter only for its intended use as designed by Amiad, any misuse of the filter may lead to undesired damage and may affect your warranty coverage. Please consult with Amiad prior to any non-regular use of this equipment.

### Installation

#### **General**

- Install the filter according to the detailed Installation Instructions provided with the filter by the manufacturer and according to the description given in this manual.
- Make sure to leave enough clearance so as to enable easy access for future treatments and safe maintenance operations.
- The user should arrange suitable lighting at the area of the filter to enable good visibility and safe maintenance.
- The user should arrange suitable platforms, ladders and safety barriers to enable easy and safe access to the filter without climbing on pipes and other equipment. The user should verify that any platform, barrier, ladder or other such equipment is built, installed and used in accordance with the relevant local authorized standards.
- Check and re-tighten all bolts during commissioning and after the first week of operation.
- Use only appropriate standard tools and equipment operated by qualified operators when installing, operating and maintaining the filter.
- When installation is required in hazardous environment sites, underground or high above ground, make sure that the site design and the auxiliary equipment are appropriate and that installation procedures are carried out in accordance with the relevant standards and regulations.
- Ensure walking areas about the installation are slip free when wet.

#### **Shipment and transporting**

- Shipping and transporting the filter must be done in a safe and stable manner and in accordance with the relevant standards and regulations.
- For shipping, lifting and positioning the filter, use only approved lifting equipment and authorized employees and contractors.

#### **Electricity**

- Electric wiring should be performed by an authorized electrician only, using standardized and approved components.
- Install a **lockable** main power cut-off switch close to the control panel.
- If due to site constraints, the control panel is installed without a clear line-of sight of the filter, an additional **lockable** power disconnect cut-off switch should be installed near each filter unit.
- Installation of the filter should be performed so as to avoid direct water splashing on the electrical components or on the control panel.

### **Pneumatics**

- Install a **lockable** main cut-off switch, **featured with a pressure release mechanism**, on the compressed air supply line close to the control panel.
- If the control panel is installed far away and there is no eye contact with the filter, a **lockable** compressed air cut-off switch, **featured with a pressure release mechanism**, should be installed near each filter unit.
- The user should make sure that the compressed air supplied to the filter never exceeds the maximum designated pressure for this filter. An air-pressure reduction valve should be installed on the compressed air supply line upstream of the filter's pneumatic inlet port.

### **Hydraulics**

- Extra safety devices should be installed on hot water applications to avoid skin burn danger.
- The user should install a manual Water Cut-off Valve next to the filter's inlet port.
- In cases where the downstream piping network downstream of the filter is pressurized an additional manual Water Cut-off Valve should be installed next to the filter outlet port.
- The user should make sure that the system includes a Pressure Release / Drainage Valve to enable release of residual pressure prior to any maintenance procedure performed on the filter.
- The user should make sure that the filter is never exposed to water pressure exceeding the maximum designated pressure for this filter, if needed a Pressure Reduction Valve should be installed upstream of the filter's water inlet port.
- Please note that the maximum working pressure indicated at the filter's specifications table includes the pressure caused by fluid hammer and pressure surge effects.

### **Civil Engineering**

- Make sure that the filter installation is done by Amiad qualified technicians.
- Make sure that any civil engineering work at the installation site such as construction, lifting, welding, etc. is done by qualified workers / technicians / contractors and in accordance with the relevant local standards.
- While using lifting equipment, make sure that the filter or the lifted part is chained securely and in a safe manner.
- Do not leave lifted equipment if there is no necessity. Avoid working below lifted equipment.
- Wear a safety helmet while using lifting equipment.
- Make sure that the flooring is sloped for drainage and to avoid accumulation of liquids.

### **Commissioning**

- Read carefully the Commissioning and the First Start-up Operation instructions prior to any attempt to operate the filter.
- In order to achieve maximum performance and smooth operation of the filter it is crucial to perform the Startup and First Operation procedures exactly as described in this manual.
- Commissioning the filter should be done by an authorized Amiad technician, do not attempt to commission the filter unaccompanied since this may lead to undesired damage and may affect your warranty coverage.

### **Operation and Control**

- Do not operate the filter before reading carefully and being familiar with its operation instructions.
- Observe the safety stickers on the filter and never perform any operation contradicting the instructions given.
- Never operate or use the filter for purposes other than its original design and operational envelope.

## **Maintenance**

### **Before any maintenance or non-regular operation please read the following:**

- Servicing the filter should be done only by technicians authorized by Amiad.
- Disconnect the filter from the power supply and lock the Main Power Switch.
- Disconnect the compressed air supply, release the residual pressure and lock the Pneumatics Main Valve.
- Disconnect the filter from the water system by closing and securing the Manual Inlet Valve. In cases where the downstream piping network is pressurized, close and secure the Manual Outlet Valve also.
- Release the residual water pressure by opening the Pressure Release / Drainage Valve.
- Empty the filter by opening the Drainage Valve.
- In hot water systems wait till the filter components cool off to a safe temperature.
- Place warning signs around the work area as required by the local standards and procedures.
- Inspect the filter's safety stickers and replace any damaged or faded sticker.

### **Mechanical**

- When working on the filter use only appropriate standard tools.
- Always open and close valves slowly and gradually.
- Remove grease and fat material residues in order to avoid slipping.
- Before disconnecting the filter from the water supply, electricity and pneumatics and before releasing the filter's residual pressure do NOT:
  - loosen or unscrew bolts
  - remove any protection cover
  - open any service port flange
- Avoid splashing and water leakage so as to minimize slippage, electrification or damage to the equipment, caused by moisture.
- While using lifting equipment, make sure that the filter or the lifted part is chained securely and in a safe manner.
- Do not leave lifted equipment if there is no necessity. Avoid working below lifted equipment.
- Wear a safety helmet, goggles, gloves, and any other personal safety equipment required by the local standards and regulations.
- Human entry into a filter must be done in accordance with the relevant local safety instructions, standards and regulations for working in hazardous environment.
- Manual cleaning of filter media using high water pressure or steam should be performed in accordance with the cleaning system instructions, the local standards and regulations and without endangering the operator or the vicinity
- Manual cleaning of filter element using acid or other chemical agents should be performed in accordance with the relevant material safety instructions, the local standards and regulations and without endangering the operator or his vicinity.

### **Before returning to regular operation**

- Re-assemble any protection covers or protection mechanisms removed during service or maintenance operations.
- Make sure that all the tools, ladders, lifting devices, etc. used during the maintenance procedures are taken away from the filter area and stored
- In order to return the filter to regular operation, follow the First Start-up Operation instructions as detailed in your user manual.
- For filters used in potable water systems it is required to disinfect the filter according to the local water authority standards and regulations before putting it back to service.

## DIMENSIONAL DRAWING & RECOMMENDED INSTALLATION

This is a conceptual installation drawing. Note that piping is not included.

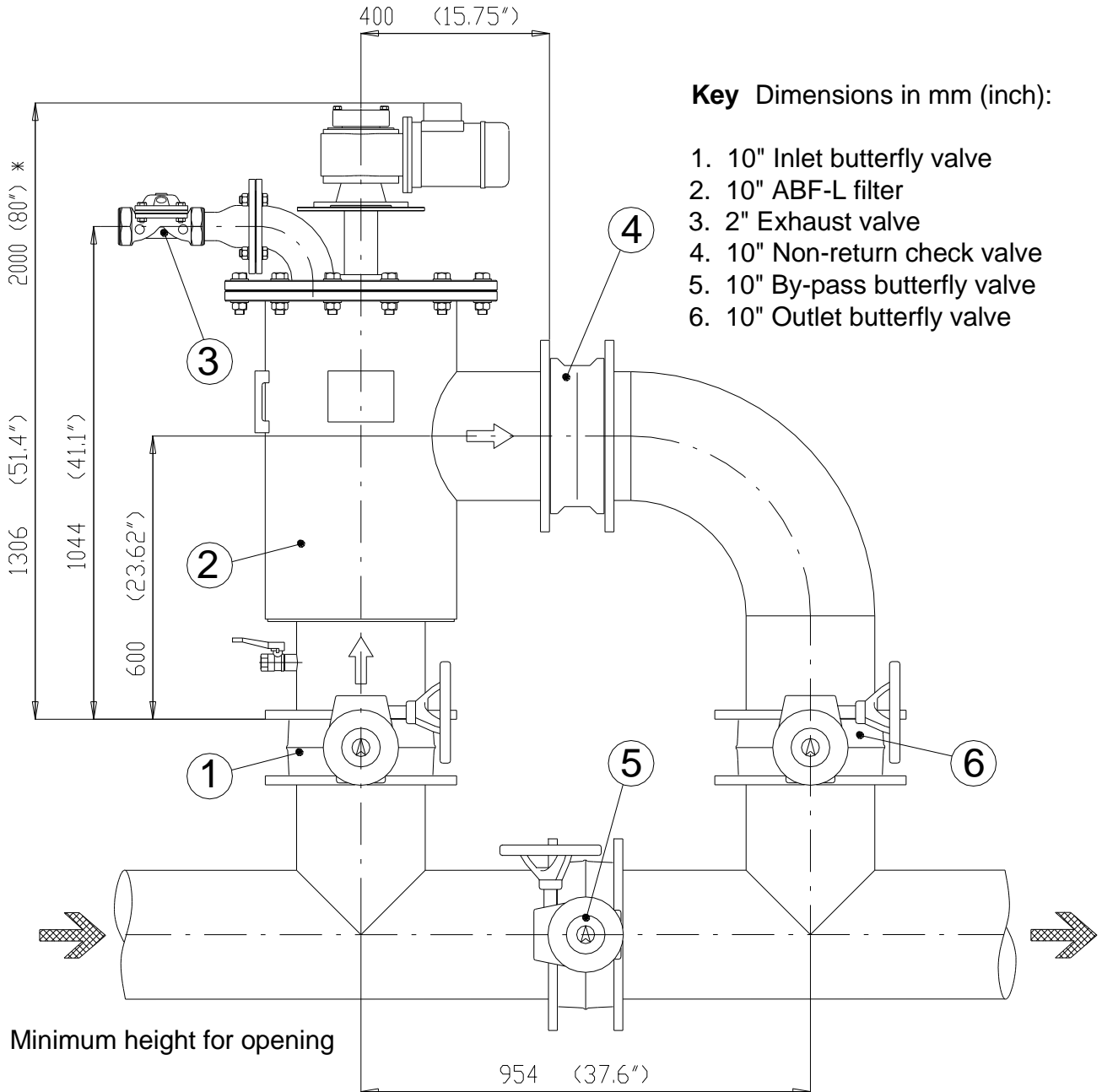



## INTRODUCTION

The automatic "ABF-6000" electric filter is a heavy duty, 90° in line filter, which has built in automatic self-cleaning features to maintain and clean the filter screen during operation. The filter is designed to achieve filtration from 3500 micron to 200 micron through varying the filter screen size. The "ABF-6000" filter is available in sizes ranging from 8" to 14".

The automatic self-cleaning operation is monitored by the PDS (17) (Pressure Differential Switch) that senses the pressure drop between the inlet and the outlet of the filter. The PDS is factory preset to start the flushing cycle at 0.5 bar (7psi) pressure differential.

### Cleaning Process:

When the pressure drop between the inlet and the outlet of the filter reaches the preset value, cleaning of the filtration cylinder is operated automatically.

This operation consists of opening an exhaust valve (12) located on the housing lid and starting the electric motor (10) which revolves two stainless steel brushes (6) on the inside of the filtration cylinder (5).

The particles trapped on the cylinder are dislodged by the revolving brushes and flushed out through the open exhaust valve (12).

The cleaning operation duration is approximately 15 seconds. The service flow of the filtered water is continuous during the cleaning cycle.

Automatic operation is controlled by the electric board that is supplied with the filter.

### Stages of Flushing Cycle:

1. The P.D. Switch sends a signal to the electric board when 0.5bar (7psi) pressure differential has occurred.
2. The exhaust valve opens to the atmosphere.
3. The motor starts rotating the shaft (6) with the brushes for approximately 15 seconds.
4. The exhaust valve closes.

Through the self cleaning process there is no interruption of flow, and the PDS is constantly monitoring the pressure differential between the inlet and outlet of the filter.

## INSTALLATION AND START-UP INSTRUCTIONS

### Mechanical Considerations

1. Select a convenient location for the installation of the filter where operation and maintenance will be optimum.
2. It is recommended to prepare a beam or any other arrangement which will allow hanging a crane for opening the filter.
3. Install the filter vertically. Please note that a minimum clearance of 700mm (28inch) is required in order to allow disassembly of the unit.
4. Make sure that the direction of the flow is as indicated by the arrow marked on the filter housing. (Flow outlet will always be from the side; flow inlet is from the bottom).
5. If possible, prior to installing the filter, flush the main line, at the connection point thoroughly, in order to remove large objects which may damage the filters internal mechanism.
6. Install a drainage pipe to the exhaust valve (12). Minimum 2" diameter for a maximum pipe length of 20 meters (60 feet) for longer drainage, a 3" pipe diameter must be used for a maximum length of 40 meters (120 feet). Please note, that no restriction is allowed on the drainage pipe. For special applications, please consult the manufacturer.

### Electrical Considerations

1. Connect the appropriate electrical power supply to the control board and the interconnections between the control board and the electrical components on the filter, according to the wiring diagram provided.
2. Install fuses as noted on the electrical schematic and ensure that all electrical connections are well insulated.
3. The electrical wires (conduit) connecting the control board and the filter should be of sufficient length to enable disassembly of the drive unit from the lid without disconnecting these wires.

### Start-up Considerations

1. Switch on the main circuit breaker.
2. Press the "TEST" push-button and check the direction in which the motor is rotating. The motor should rotate the brush shaft clockwise. If it is rotating in the other direction - change the direction by swapping the phase connections.
3. Open slowly the valve at the inlet of the filter. If possible with an outlet valve closed and a by-pass valve open, and repeat a manual flushing.
4. Open the outlet valve gradually and bring the filter to normal working condition.
5. Check that the PDS is properly functioning by draining its low pressure tube (17.7). Draining is done by means of the 1/4" valve (18). Closing the valve for at least 3 seconds will cause the PDS to send an electric signal to the control board and automatic cleaning will begin.
6. The cleaning operation should be for 15 seconds and full flow out of the exhaust valve should be observed during this entire period. After the 15 second cleaning operation, the flow out of the exhaust valve should stop immediately. Be sure to observe that there is no significant leakage occurring from the exhaust valve once the cleaning operation has completely stopped.

## ELECTRICAL CONTROL SYSTEM DESCRIPTION

The ABF-L control board monitors and operates the filter self-cleaning process. The self-cleaning process includes simultaneous operation of the motor and opening of the exhaust valve. The control board will cause the initiation of a flushing cycle as a result of each of the following reasons:

1. Signal from the **PDS**.
2. Manual initiation by **TEST / RESET** push-button.
3. Internal timer, up to 30 hours.

During operation condition the Main Switch, the Motor Protector and the **F2** Circuit Breaker must be "**ON**". In this condition the power pilot light is lit.

### Flushing by PDS

The signal duration from the **PDS** should be longer than the preset time in timer **T0**. It is recommended to set it to 3-5 seconds.

This delay will prevent the filter from entering into flushing mode as a result of a momentary signal from the **PDS**.

### Flushing by manual operation

Quick pressing on the **TEST / RESET** push button will cause operation of self-cleaning.

### Flushing by Timer

The timer is located inside the control board and is marked "**T2**". It is possible to set it for intervals from a few minutes up to 30 hours.

To cancel the option of flushing by timer, turn off the **SW-1** switch.

The minimum flushing duration is determined by timer **T1**. It is recommended that flushing duration is set to 15 seconds.

The control board is equipped with a protection circuit. It will cause the filter to enter a "fault" mode if continuous signal from the **PDS** is received for duration longer than the preset time in **TAL**. This means that in case that the filter does not manage to clean itself; the **PDS** will continue to send a signal. When the **TAL** time elapses, flushing stops, "fault" pilot light is lit and fault relay is activated. It is possible to use this relay also for an alarm, automatic by-pass, etc.

To come out of fault mode, press the **TEST / RESET** push-button.

The recommended preset time for **TAL** is 5 minutes.

It is possible to order control boards with additional features such as sequential operation of a few filters in a battery, flushing counter, etc.

Follow the drawing in this manual for proper wiring of the control board to the filter.

## DISASSEMBLING THE "ABF-6000" FILTER

1. It is recommended to initiate a cleaning cycle prior to the filter disassembling.
2. Close the inlet/outlet valves and drain the filter.
3. Cut off the electrical power.
4. Disconnect electrical cables from the drive unit (10), unless the cables are long enough and allow the motor to be removed without disconnecting it.
5. Disconnect the flushing pipe from the Exhaust Valve (12)
6. Pull the electrical plug from the solenoid valve (13).
7. Remove Pilot Tube (13.6)
8. Unscrew Bolts (10.3) and remove the drive unit and the shaft key (22.1)
9. Lift up the coupling unit (22)
10. Loosen nuts (9.4)
11. Unscrew the housing bolts (7.1) and lift up with a crane the filter Lid (7)
12. Lift up the Brush Assembly (6), together with the Screen (5), and the Screen Support (4)
13. Place the assembly beside the filter on a flat clean area.
14. Pull the Split Pin (6.6) from the Brush Spindle (6.1) and remove the Screen Support and its Seal (3+4)
15. Pull the Brush Assembly (6) out from the screen (5). Inspect the brushes and replace if necessary.
16. If necessary, remove the Screen Support Seal (3) from the Screen Support (4)

## RE-ASSEMBLING THE "ABF-6000" FILTER

1. Install the Screen Support Seal (3) on the Screen Support (4).
2. Verify that the Cylinder seals (5.1) are located properly on the Screen edges.
3. Place the Screen (5) on the Screen Support (4).
4. Insert the brush assembly (6) in a spiral motion into the Screen Cylinder. Make sure that the lower end of the Shaft is properly inserted into the bearing (4.1)
5. Put the plastic washer (6.8) on the lower end of the spindle shaft
6. Put the St.St. washer (6.9) on the lower end of the spindle shaft
7. Insert the split pin (6.6) into its hole in the brush shaft and secure it
8. Insert the brush assembly into the filter housing
9. Put the upper screen seal on the screen upper edge and lubricate it with silicon grease
10. Make sure that the housing O-ring (2) is properly placed in its groove.
11. Place the Filter Lid (7) on the filter housing. Make sure that the direction of the flushing valve is opposite to the filter outlet.
12. Tighten the Lid Bolts (7.1) as follows: Gradually tighten a bolt at one side, do not perform final tightening and move to the bolt at the opposite side of the lid and tighten it. Continue to tighten all the lid bolts according to this method. Now the final tightening of all the lid bolts can be performed.
13. Seal the shaft by tightening Nuts (9.4).
14. Place the Shaft Key (6.7) in its groove and lubricate it with grease together with the shaft.
15. Insert the coupling unit on the main shaft.
16. Put the coupling shaft key (22.1) in its groove and lubricate it with grease together with the shaft.
17. Assemble the drive unit (10) in the correct position and make sure that the shaft key is properly engaged with the key.
18. Tighten bolts (10.3)
19. Re-connect the power cables.
20. Switch the electrical power on.
21. Press the TEST push-button and make sure that the filter shaft rotates in the correct direction (according to the direction of the arrow on the lid).
22. Gradually, open the inlet valve and the outlet valve. If there is a leak from the shaft (6.1) tighten the nuts (9.4).

## MAINTENANCE

### General inspection:

In order to check the proper operation of the filter, close the 1/4" valve (# 18) for about 5 seconds. This will initiate the self-cleaning cycle: Check that the exhaust valve opens, the motor is moving and the brushes shaft is rotating.

### Weekly maintenance:

1. Check that the filter operates properly, following a general inspection.
2. Clean the 3/4" filter (close the 3/4" valve and operate a flushing cycle in order to release pressure and then open the bowl).
3. If necessary, take care of any leakage from the spindle shaft by tightening the nuts (9.4). (Do not tighten them too tight. If needed change the sealing ropes).

### Maintenance prior to long term cessation of filter operation:

The following must be done if the filter will not be in operation for more than a month.

1. Operate a flushing cycle (If possible, with a closed downstream valve).
2. Disconnect the control board from the power supply.
3. Release pressure from the filter.
4. Clean the 3/4" control filter.

### Maintenance prior to re-operation:

1. Change the shaft sealing ropes (9.5).
2. Connect the control board to the mains.
3. Check proper operation of the filter.

## TROUBLESHOOTING

No.	Fault	Type of Fault	Correcting the Fault
1	Motor shaft does not rotate while the motor runs.	The spline in the motor gear box is broken.	The drive unit requires overhaul.
2	Trip of over load switch.	a. Brush stuck	Release the brush spindle from the drive unit by removing 4 bolts that secure the drive unit to the filter body. Lift off drive unit and try to rotate spindle using adjustable crescent wrench. If brush assembly is stuck, remove filter lid to see what is blocking rotation.
		b. Filter flushes continuously	Refer to fault No.3.
		c. Electrical short circuit	Call your field service agent, or an electrician. Refer to electrical wiring schematic as necessary.
3	Filter flushes every 5 minutes	Filter is not cleaned by flush operation, or electrical short circuit at the PDS inlet.	Check the filter inlet and outlet pressure. If the difference is more than 7 psi, carry out several flush operations and recheck the pressures. If the difference is still more than 7 psi, physically remove and inspect the screen and brush, and repair them as required. If the pressure differential is less than 7 psi, the fault is caused by an electrical short circuit. Call your field service agent or an electrician. Refer to schematic drawing.
4	Exhaust valve does not operate when cleaning operation occurs.	Solenoid valve malfunctions	Disassemble the solenoid valve, clean all water passages and ensure all electrical connections are made and functioning properly. If the solenoid still malfunctions, replace the valve's coil, or the entire solenoid valve.
5	Exhaust valve does not close when cleaning operation is completed	a. Pilot tube is clogged	Ensure that all water passages in the valves pilot tube are free.
		b. Internal diaphragm in the valve is torn.	Replace valves diaphragm.
6	Water flow discharged from the waste exhaust pipe is too low.	Restrictions in the waste exhaust piping system.	Inspect the waste exhaust piping system and locate the causes of any restriction and remove them.
7	Water leakage from brush and frame shaft	Bushing securing the brush and is loose.	Tighten the bushing while the filter operates. If necessary, add 8mm Teflon rope around the frame brush spindle before tightening.

## Parts Schedule Standard ABF-6000

No.	Description
1	Housing (ABF-6000)
2	O-Ring P2-464
3	Hydraulic seal AM-09
4	Screen support (ABF-6000)
4.1	Plastic bushing (ABF-6000)
5	Wedgewire screen (ABF-6000)
	Perforated screen (ABF-6000)
5.1	Screen rubber ring AM-11
6	Brush assembly (ABF-6000)
	Brush assembly -Nylon
6.1	Spindle and frame (ABF-6000)
6.2	Brush - one unit (ABF-6000)
	Brush - one unit Nylon
6.3	Bolt M6 x 25 (St.St.) [x10]
6.4	Washer M6 (St.St.) [x10]
6.5	Nut M6 (St.St.) [x10]
6.6	Split pin 3 x 40
6.7	Key 8mm x 8mm
6.8	Lower plastic washer
6.9	St.St. Washer M27
7	Lid (ABF-6000)
7.1	Bolt M20 x 80 z. plated
7.2	Washer M20 z. plated [x12]
7.3	Washer M20 z. plated [x12]
7.4	Nut M20 z. plated [x12]
7.5	Set screw M10 x 50 (St.St.)
7.6	Washer M10 (St.St.) [x4]
7.7	Spring washer M10 (St.St.) [x4]
7.8	Nut M10 (St.St.) [x4]
8	Drive unit support (ABF-6000)
9	Sealing ropes tightening bushing
9.1	Shaft seal tightening plate
9.2	Set screw M10 x 50 (St.St.)
9.3	Washer M10 (St.St.) [x2]
9.4	Nut M10 (St.St.) [x2]
9.5	Sealing rope set (ABF-6000)
10	Drive unit (ABF-6000)
10.1	Motor 380-480V 50/60 Hz 3/4 HP
10.2	Worm gear RMI 70, 100:1(71)
10.3	Bolt M10 x 40 [x4]
10.4	Washer M10 z. plated [x4]
10.5	Washer M10 z. plated [x4]
10.6	Spring washer M10 z. plated [x4]
10.7	Nut M10 [x4]
10.8	Shaft cover (PVC)
10.9	Bolt M8 x 40 [x4]
10.10	Washer M8 [x4]
11	Adaptor 3" x 2" (ABF-6000)
11.1	Flange seal 3"
11.2	Bolt M16 x 50 z. plated [x4]
11.3	Washer M16 z. plated [x4]

No.	Description
11.4	Washer M16 z. plated [x4]
11.5	Nut M16 [x4]
12	Hydraulic valve 2" (RAM)
	Hydraulic valve 2" (GAL)
13	Solenoid valve 24V AC, "NO"
	Solenoid valve 24V AC, "NO"
	Solenoid valve 24V DC, "NO"
13.1	L-Connector 5/16" x 1/4"
13.2	Air-brake tube 8 mm (5/16")
13.3	Connector 5/16" x 1/4"
13.4	L-Connector 5/16" x 1/8"
13.5	Connector 1/4" x 1/4" (Brass)
13.6	Air-brake tube 8 mm (5/16")
13.7	L-Connector 5/16" x 1/4"
14	Ball valve 3/4" (Brass)
15	L-Connector 3/4" F-F (Galvanized)
15.1	Connector 3/4" x 50
16	1" C Filter (AC), w/valve, 200µ
16.1	Raccord connector 3/4" x 1"
16.2	Raccord nut
16.3	O-Ring P2-018
16.4	Raccord connector 1"
16.5	Connector 5/16" x 1/4"
16.6	Air-brake tube 8 mm (5/16")
16.7	T-Connector 5/16"
16.9	T-Connector 1/4"
17	PD switch (Midwest)
17.1	Connector 1/8" x 1/4"
17.3	Connector 5/16" x 1/8"
17.4	Air-brake tube 8 mm (5/16")
17.5	Set screw M6 x 25 (St.St.) [x2]
17.6	Washer M6 (St.St.) [x2]
17.7	Spring washer M6 (St.St.) [x2]
17.8	Nut M6 (St.St.) [x2]
18	Manometer valve 1/4"
18.1	Bushing 3/4" x 1/4" (Brass)
19	Three-way valve 1/4"
19.1	L-Connector 5/16" x 1/8"
19.2	T-Connector 1/4" (Brass)
19.3	Connector 5/16" x 1/4"
19.4	Connector 5/16" x 1/8"
19.5	Air-brake tube 8 mm (5/16")
20	Pressure gauge 1/4" (Bottom Inlet)
21	Ball valve 3/4" (Brass)
22	Coupling unit
22.1	Key 8mm x 8mm
22.2	Coupling upper part
22.3	Isolation flange
22.4	Coupling lower part
22.5	St.St. Allen Bolt M10 x 35 [x4]

# Parts Schedule Standard ABF-6000 #1

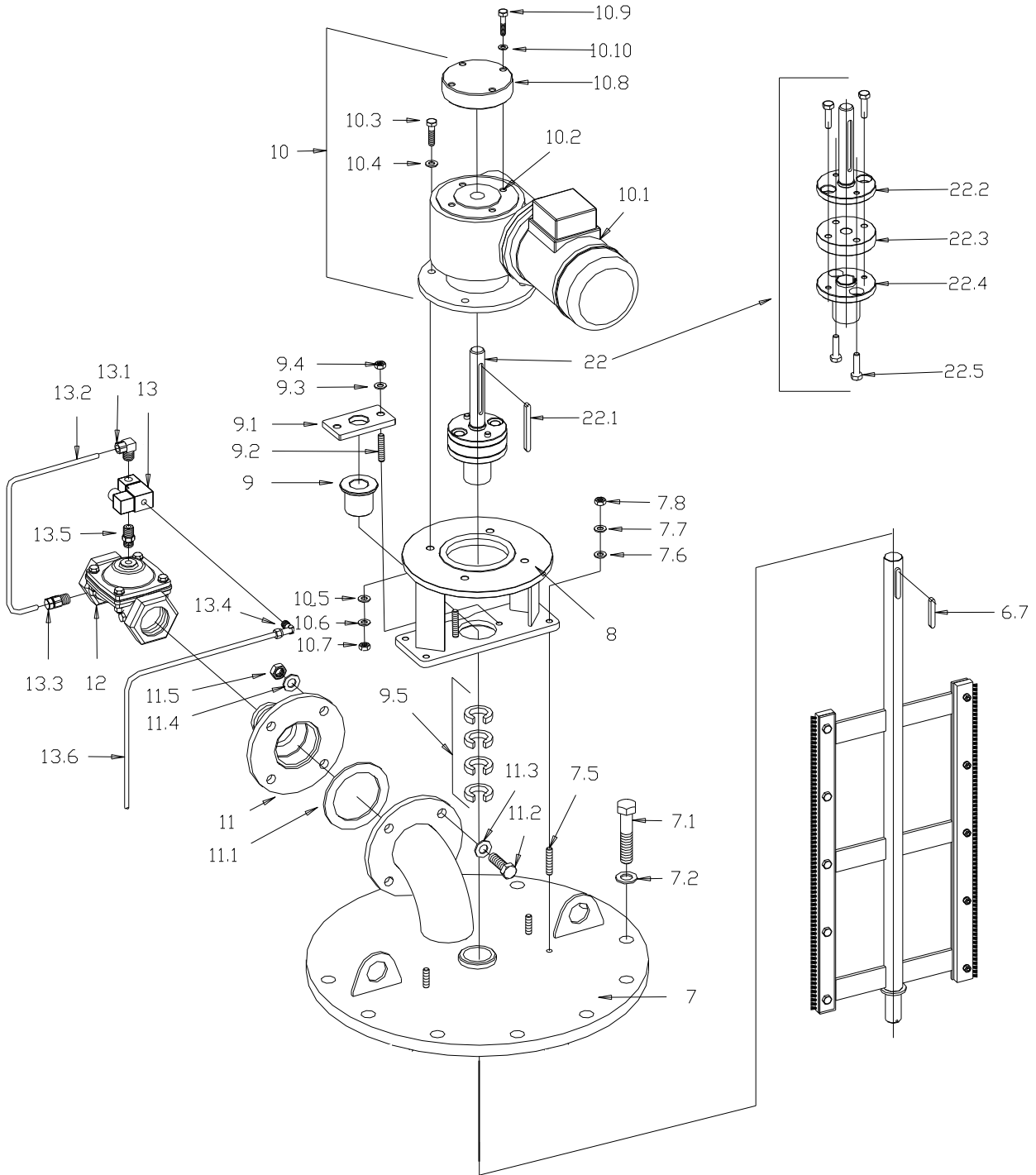



## Parts Schedule Standard ABF-6000 #2

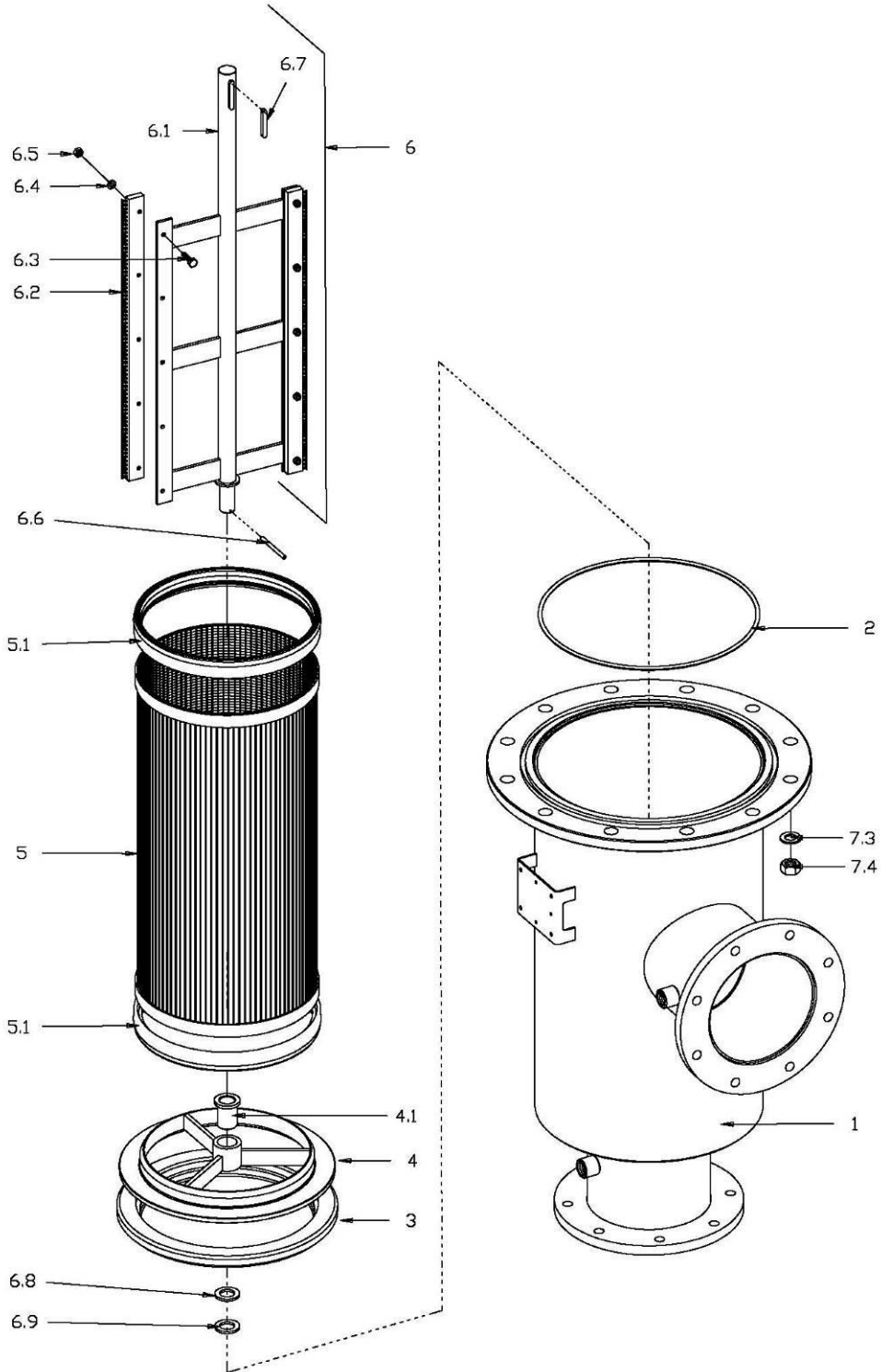

### Parts Schedule Standard ABF-6000 #3

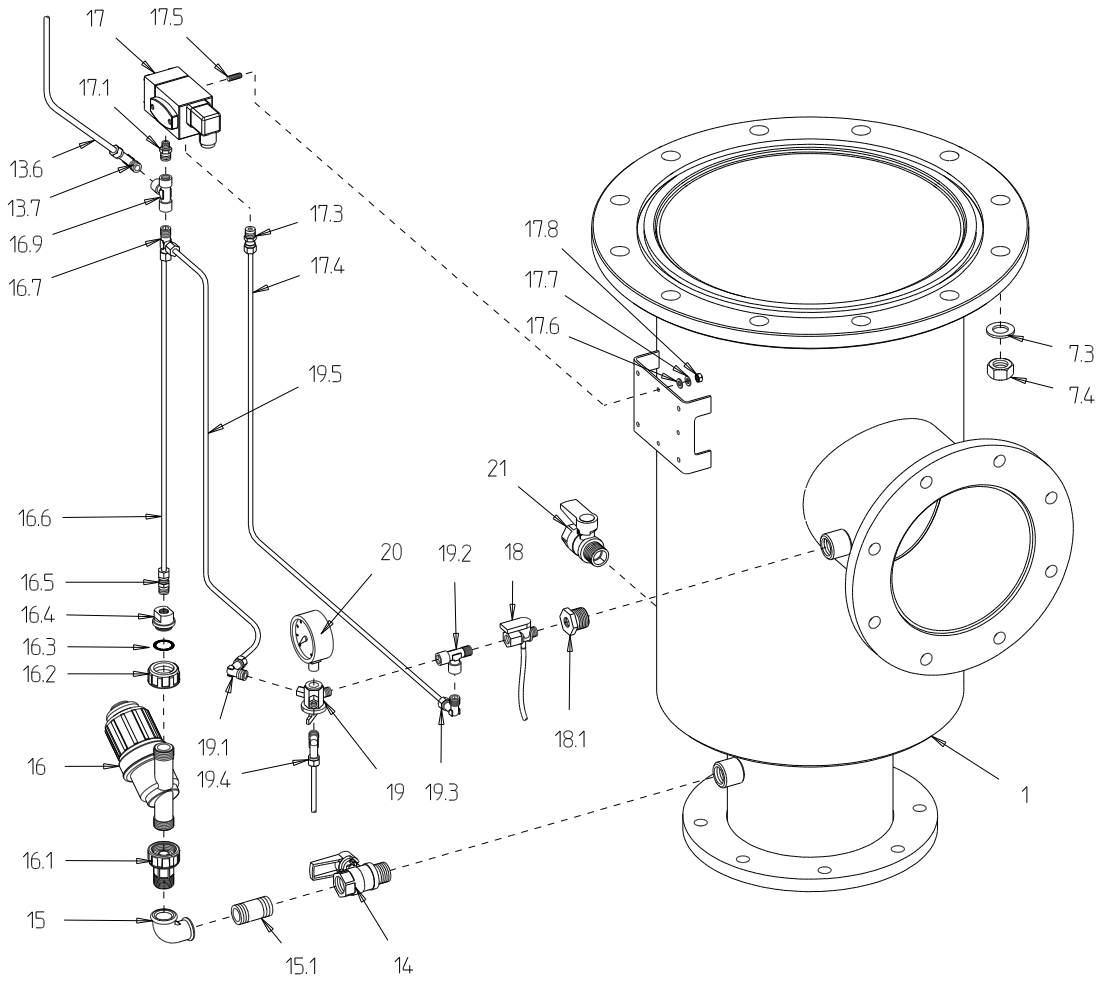

## Amiad Limited Warranty

1. This certificate applies to Amiad Water Systems Ltd. ("**Amiad**") products purchased by you (the "**Buyer**") from Amiad unless specifically agreed otherwise in writing by Amiad. This Warranty extends only to the original purchaser, and is not transferable to anyone who subsequently purchases, leases, or otherwise obtains the product from the original purchaser.
2. Amiad hereby warrants that the products are and will be free from defects in material and workmanship under normal use and service. Amiad warrants that it will correct manufacturing defects in the products, in accordance with the conditions set out in this Warranty.
3. This Warranty is enforceable for a period of 12 months after the date upon which the products were delivered (the "**Warranty Period**").
4. In the event that during the Warranty Period the Buyer discovers a defect in material and/or workmanship in any product or part (the "**Defective Product**"), it shall submit a written complaint to Amiad using Amiad's standard Buyer Complaint Form. For the receipt of the Buyer Complaint Form, the submission of the complaint or any questions please contact your service representative.
5. Upon written demand by Amiad the Buyer shall return the Defective Product - or a sample thereof - to Amiad, at Amiad's cost. If the Buyer ships any such Defective Product, Amiad suggests the Buyer package it securely and insure it for value, as Amiad assumes no liability for any loss or damage occurring during shipment. Provided however that in the event Amiad determines that this Warranty does not apply to such product, Buyer shall promptly reimburse Amiad for such cost (including freight and customs). Any returned product or part must be accompanied by the Warranty certificate and the purchase invoice. It is clarified that the Buyer may not return the Defective Product unless such return was coordinated and approved by Amiad in advance.
6. Amiad's obligation under this Warranty shall be limited to, at Amiad's option, the repair or exchange, free of charge, of the product or any part which may prove defective under normal use and service during the Warranty Period. The provision of a repair or replacement of a product during the Warranty Period will result in an extension of the Warranty Period by an additional period of 12 months, provided that the total accumulated Warranty Period shall in any event be no more than 18 months from the date upon which the products were delivered.
7. This Warranty is valid on the condition that the products are installed according to Amiad's instructions as expressed in Amiad's instruction manuals and according to the technical limitations as stipulated in Amiad's literature or as stated by a representative of Amiad.
8. This Warranty will not apply to damaged or defective products resulting from or related to:
  - (i) Fire, flood, power surges or failures or any other catastrophe and/or unforeseen occurrence, such as but not limited to those for which the Buyer is customarily insured for, or any force majeure events;
  - (ii) Fault, abuse or negligence of the Buyer;
  - (iii) Intake water not meeting the agreed standards, as set forth in a written document, approved by Amiad, or improper storage;
  - (iv) Improper or unauthorized use of the product or related parts by the Buyer, including Buyer's failure to operate the product in conformity with the recommendations and instructions of Amiad, as set forth in Amiad's manuals and other written materials, the operation of the product other than by a trained and qualified operator, or improper installation of the product by a third party not authorized by Amiad;
  - (v) Performance by the Buyer of maintenance or operation other than in conformity with the recommendations and instructions of Amiad, or other than in accordance with procedures defined in the literature supplied for products (including the timely replacement of requisite parts), and for services provided other than by a trained and qualified advanced operator; or
  - (vi) Any alteration, modification, foreign attachment to or repair of the products, other than by Amiad or its authorized technical representatives.
9. In no event shall Amiad be liable to the Buyer or any third party for any damages to property, or for any intangible or economic loss, including loss of profits, loss of customers or damage to reputation, for any damages, including indirect, special, consequential damages, or punitive damage arising out of or in connection with this Warranty, or arising out of or in connection with the product's performance or failure to perform, even if it has been advised of the possibility of such damages.
10. Amiad will be excused for failure to perform or for delay in performance hereunder if such failure or delay is due to causes beyond its reasonable control or force majeure preventing or hindering performance.
11. This Warranty set forth herein is the only contractual warranty given by Amiad and is provided in lieu of any other warranties created by any documentation, packaging or otherwise.
12. Amiad makes no warranty whatsoever in respect to accessories or parts not supplied by Amiad. In the event that Amiad is required to correct a Defective Product or product not covered by this Warranty, it will do so solely in consideration for additional fees.
13. The parties will actively endeavor to amicably settle any dispute arising between them. In the event that the parties are unable to reach an equitable settlement of such dispute, any claim or lawsuit related to the Warranty, its validity execution, its performance be brought before only the courts of Tel-Aviv, Israel. Israeli law will govern the Warranty, to the exclusion of any conflict of law rules .



**Amiad Water Systems Ltd.** D.N. Galil Elyon 1, 1233500, Israel.

Tel: +972 4690 9500 | Fax: +972 48141159 | Email: [info@amiad.com](mailto:info@amiad.com)

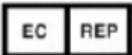

**Obelis s.a.** Bd Général Wahis 53, 1030 Brussels, Belgium.

Tel: +(32) 2732 5954 | Fax: +(32) 27326003 | Email: [mail@obelis.net](mailto:mail@obelis.net)

**EC Declaration**

<https://www.amiad.com/certificatesDownload.asp>