

AMIAD Water Systems

ABF-15,000 IN-LINE FILTER Automatic Brush Filter

Serial number:	
Order number:	
Catalog number:	
Filtration degree:	
Tested by:	

Installation, Operation and Maintenance Instructions



910101-000320 / 09.2017

AMIAD Water Systems

ABF-15,000 IN-LINE FILTER Automatic Brush Filter

Disclaimer:

Copyright © 2017 Amiad Water Systems Ltd. All rights reserved.

The contents of this document, including without limitation all information and materials, images, illustrations, data, drawings, names and any other such materials that appear in this document are the sole property of Amiad Water Systems Ltd. ("Amiad"), including any intellectual property rights, whether registered or not, and all know-how contained or embodied therein (together the "Content"). Amiad may alter, remove or change the Content without any further notice. You may not reproduce, copy, modify, create derivative works from, sell or participate in any sale of, or exploit in any way, in whole or in part, any of this document or its Content.

The confidential nature of and/or privilege in the file enclosed is not waived or lost as a result of a mistake or error in this file. If you received this file in error, please notify Amiad immediately at info@amiad.com.

This document does not replace any certified drawing, procedure or information provided by Amiad in reference to a specific customer, site or project.

Amiad assumes that all users understand risks involved within this file and/or its attached materials. This document is given in good faith and is not intended to impose any obligation to Amiad. While every effort has been made to ensure the information in this manual is accurate and complete, we would appreciate if you can bring any errors or omissions to the knowledge of Amiad or consult Amiad experts or its authorized representatives if you have any questions.

Amiad Water Systems Ltd. D.N. Galil Elyon 1, 1233500, Israel Tel: 972 4 690 9500 | Fax: 972 4 814 1159 Email: info@amiad.com

TABLE OF CONTENTS

SPECIFICATIONS	5
GENERAL	5
FLUSH DATA	5
CONTROL AND ELECTRICITY.....	5
CONSTRUCTION MATERIALS.....	5
FILTRATION DEGREES AVAILABLE.....	5
SAFETY INSTRUCTIONS	6
GENERAL SAFETY INSTRUCTIONS	6
INSTALLATION.....	6
COMMISSIONING	7
OPERATION AND CONTROL.....	7
MAINTENANCE	8
DIMENSIONAL DRAWING	9
DESCRIPTION OF FILTER OPERATION	10
CLEANING PROCESS:	10
STAGES OF FLUSHING CYCLE:	10
INSTALLATION AND START-UP INSTRUCTIONS	11
MECHANICAL CONSIDERATIONS	11
ELECTRICAL CONSIDERATIONS	11
START-UP CONSIDERATIONS	11
ELECTRICAL CONTROL SYSTEM DESCRIPTION	12
FLUSHING BY PDS:	12
MANUAL OPERATION:.....	12
FLUSHING ACCORDING TO TIME:	12
FAULT MODE:	12
DISASSEMBLING THE "ABF-15,000" FILTER	13
RE-ASSEMBLING THE "ABF-15,000" FILTER	13
MAINTENANCE	14
GENERAL INSPECTION.....	14
WEEKLY MAINTENANCE	14
ANNUAL MAINTENANCE.....	14
MAINTENANCE PRIOR TO LONG TERM CESSATION OF FILTER OPERATION	14
MAINTENANCE PRIOR TO RE-OPERATION.....	14
PARTS SCHEDULE	15
PARTS DRAWING #1	16
PARTS DRAWING #2	16
PARTS DRAWING #3	18

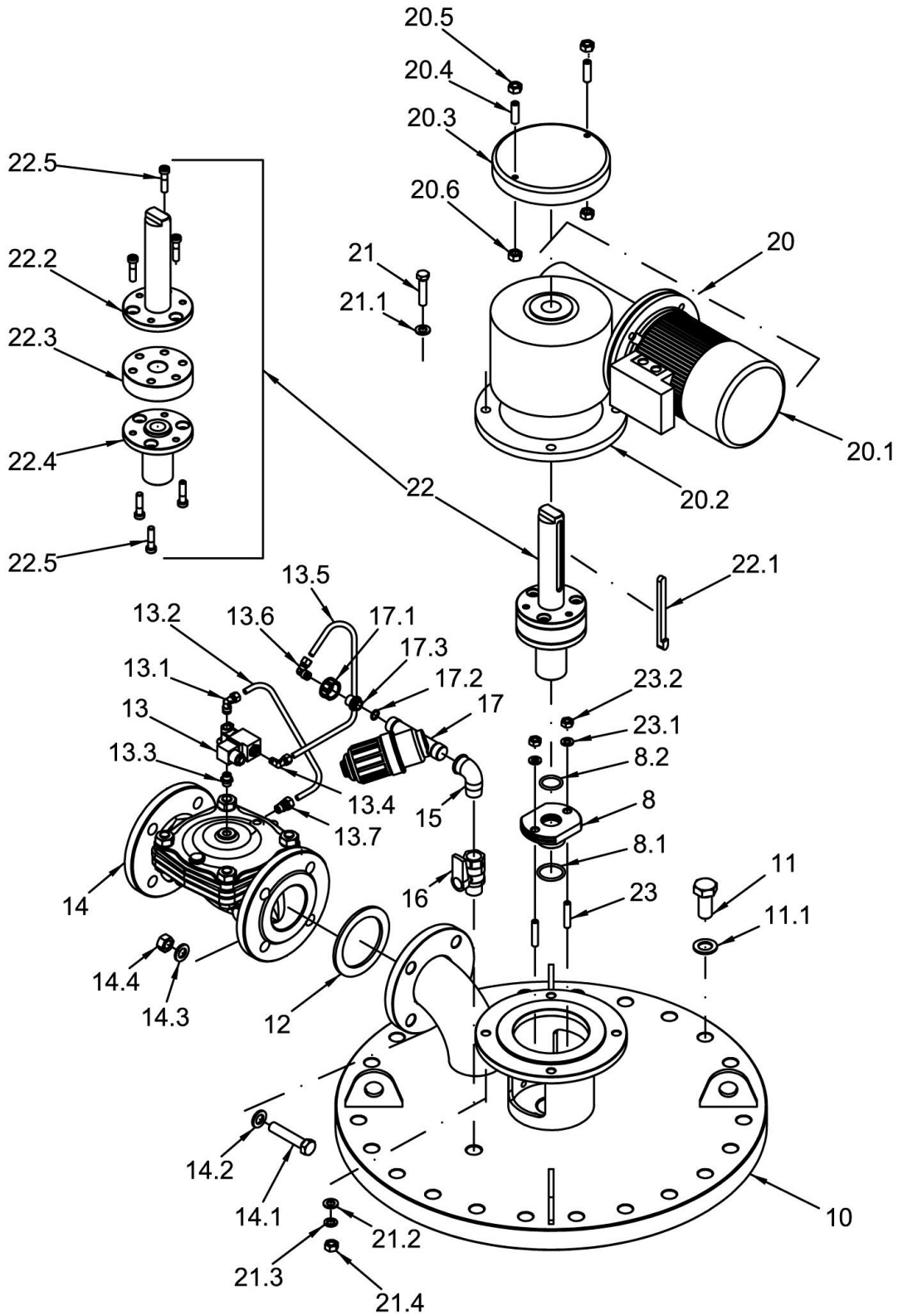

..... 18

With any inquiry please quote Filter Serial Number, located on the filter nameplate.

SPECIFICATIONS

General

Maximum flow rate	1500m ³ /h; 6600USgpm	Consult manufacturer for optimum flow depending on filtration degree & water quality.
Min. working pressure	1bar; 15psi	Or lower if pressure is increased for flushing
Max. working pressure	10bar; 150psi	16 bar (240 psi) upon request
Filter area	15000cm ² ; 2325in ²	
Inlet/Outlet diameter	14", 16", 18", 20" 350, 400, 450, 500mm	Flange standards as per request.
Filter housing diameter	700mm; 28"	
Max. working temperature	60°C; 140°F	
Type of screen	800 - 3500 micron	Perforated screen
	200 - 800 micron	Wedgewire screen

Flush data

Exhaust valve	80mm; 3"	
Flushing cycle time	15 seconds	
Wasted water per cycle	300liter; 80USgal	at 4 bar (60 psi)
Minimum flow for flushing	70m ³ /h; 310USgpm	

Control and electricity

Electric motor	1.5 HP / 15-18 Output R.P.M
Rated operation voltage	3 phase, 380V 50 Hz, or 220/440V 60 Hz
Upon request	24V DC
Control voltage	24V AC (24V DC upon request)

Construction materials

Filter housing and lid	Carbon Steel 37-2 (Stainless Steel available on request)
Screen	Stainless Steel 316L
Cleaning mechanism	Stainless Steel 316 , PVC and Delarin
Exhaust valve	Epoxy-Coated, Cast Iron
Seals	Nitrile rubber, Natural rubber, Teflon
Control system	Brass, Stainless Steel, Engineering plastic, Polyethylene

Filtration degrees available

	Perforated screen				Wedgewire screen			
micron	3500	2500	1500	800	800	500	300	200
mm	3.5	2.5	1.5	0.8	0.8	0.5	0.3	0.2

SAFETY INSTRUCTIONS

General Safety Instructions

- Amiad filtration products always operate as components in a larger system. It is essential for the system designers, installers and operators to comply with all the relevant safety standards.
- Prior to installation, operation, maintenance or any other type of action carried out on the filter, read carefully the safety, installation and operation instructions.
- During installation, operation or maintenance of the filter all conventional safety instructions should be observed in order to avoid danger to the workers, the public or to property in the vicinity.
- Please note: The filter enters into a flushing mode automatically, without prior warning.
- No change or modification to the equipment is permitted without a written notification given in advance by the manufacturer or by its representative, on the manufacturer's behalf.
- Always observe standard safety instructions and good engineering practices whilst working in the filter's vicinity.
- Use the filter only for its intended use as designed by Amiad, any misuse of the filter may lead to undesired damage and may affect your warranty coverage. Please consult with Amiad prior to any non-regular use of this equipment.

Installation

General

- Install the filter according to the detailed Installation Instructions provided with the filter by the manufacturer and according to the description given in this manual.
- Make sure to leave enough clearance so as to enable easy access for future treatments and safe maintenance operations.
- The user should arrange suitable lighting at the area of the filter to enable good visibility and safe maintenance.
- The user should arrange suitable platforms, ladders and safety barriers to enable easy and safe access to the filter without climbing on pipes and other equipment. The user should verify that any platform, barrier, ladder or other such equipment is built, installed and used in accordance with the relevant local authorized standards.
- Check and re-tighten all bolts during commissioning and after the first week of operation.
- Use only appropriate standard tools and equipment operated by qualified operators when installing, operating and maintaining the filter.
- When installation is required in hazardous environment sites, underground or high above ground, make sure that the site design and the auxiliary equipment are appropriate and that installation procedures are carried out in accordance with the relevant standards and regulations.
- Ensure walking areas about the installation are slip free when wet.

Shipment and transporting

- Shipping and transporting the filter must be done in a safe and stable manner and in accordance with the relevant standards and regulations.
- For shipping, lifting and positioning the filter, use only approved lifting equipment and authorized employees and contractors.

Electricity

- Electric wiring should be performed by an authorized electrician only, using standardized and approved components.
- Install a **lockable** main power cut-off switch close to the control panel.
- If due to site constraints, the control panel is installed without a clear line-of sight of the filter, an additional **lockable** power disconnect cut-off switch should be installed near each filter unit.
- Installation of the filter should be performed so as to avoid direct water splashing on the electrical components or on the control panel.

Pneumatics

- Install a **lockable** main cut-off switch, **featured with a pressure release mechanism**, on the compressed air supply line close to the control panel.
- If the control panel is installed far away and there is no eye contact with the filter, a **lockable** compressed air cut-off switch, **featured with a pressure release mechanism**, should be installed near each filter unit.
- The user should make sure that the compressed air supplied to the filter never exceeds the maximum designated pressure for this filter. An air-pressure reduction valve should be installed on the compressed air supply line upstream of the filter's pneumatic inlet port.

Hydraulics

- Extra safety devices should be installed on hot water applications to avoid skin burn danger.
- The user should install a manual Water Cut-off Valve next to the filter's inlet port.
- In cases where the downstream piping network downstream of the filter is pressurized an additional manual Water Cut-off Valve should be installed next to the filter outlet port.
- The user should make sure that the system includes a Pressure Release / Drainage Valve to enable release of residual pressure prior to any maintenance procedure performed on the filter.
- The user should make sure that the filter is never exposed to water pressure exceeding the maximum designated pressure for this filter, if needed a Pressure Reduction Valve should be installed upstream of the filter's water inlet port.
- Please note that the maximum working pressure indicated at the filter's specifications table includes the pressure caused by fluid hammer and pressure surge effects.

Civil Engineering

- Make sure that the filter installation is done by Amiad qualified technicians.
- Make sure that any civil engineering work at the installation site such as construction, lifting, welding, etc. is done by qualified workers / technicians / contractors and in accordance with the relevant local standards.
- While using lifting equipment, make sure that the filter or the lifted part is chained securely and in a safe manner.
- Do not leave lifted equipment if there is no necessity. Avoid working below lifted equipment.
- Wear a safety helmet while using lifting equipment.
- Make sure that the flooring is sloped for drainage and to avoid accumulation of liquids.

Commissioning

- Read carefully the Commissioning and the First Start-up Operation instructions prior to any attempt to operate the filter.
- In order to achieve maximum performance and smooth operation of the filter it is crucial to perform the Startup and First Operation procedures exactly as described in this manual.
- Commissioning the filter should be done by an authorized Amiad technician, do not attempt to commission the filter unaccompanied since this may lead to undesired damage and may affect your warranty coverage.

Operation and Control

- Do not operate the filter before reading carefully and being familiar with its operation instructions.
- Observe the safety stickers on the filter and never perform any operation contradicting the instructions given.
- Never operate or use the filter for purposes other than its original design and operational envelope.

Maintenance

Before any maintenance or non-regular operation please read the following:

- Servicing the filter should be done only by technicians authorized by Amiad.
- Disconnect the filter from the power supply and lock the Main Power Switch.
- Disconnect the compressed air supply, release the residual pressure and lock the Pneumatics Main Valve.
- Disconnect the filter from the water system by closing and securing the Manual Inlet Valve. In cases where the downstream piping network is pressurized, close and secure the Manual Outlet Valve also.
- Release the residual water pressure by opening the Pressure Release / Drainage Valve.
- Empty the filter by opening the Drainage Valve.
- In hot water systems wait till the filter components cool off to a safe temperature.
- Place warning signs around the work area as required by the local standards and procedures.
- Inspect the filter's safety stickers and replace any damaged or faded sticker.

Mechanical

- When working on the filter use only appropriate standard tools.
- Always open and close valves slowly and gradually.
- Remove grease and fat material residues in order to avoid slipping.
- Before disconnecting the filter from the water supply, electricity and pneumatics and before releasing the filter's residual pressure do NOT:
 - loosen or unscrew bolts
 - remove any protection cover
 - open any service port flange
- Avoid splashing and water leakage so as to minimize slippage, electrification or damage to the equipment, caused by moisture.
- While using lifting equipment, make sure that the filter or the lifted part is chained securely and in a safe manner.
- Do not leave lifted equipment if there is no necessity. Avoid working below lifted equipment.
- Wear a safety helmet, goggles, gloves, and any other personal safety equipment required by the local standards and regulations.
- Human entry into a filter must be done in accordance with the relevant local safety instructions, standards and regulations for working in hazardous environment.
- Manual cleaning of filter media using high water pressure or steam should be performed in accordance with the cleaning system instructions, the local standards and regulations and without endangering the operator or the vicinity
- Manual cleaning of filter element using acid or other chemical agents should be performed in accordance with the relevant material safety instructions, the local standards and regulations and without endangering the operator or his vicinity.

Before returning to regular operation

- Re-assemble any protection covers or protection mechanisms removed during service or maintenance operations.
- Make sure that all the tools, ladders, lifting devices, etc. used during the maintenance procedures are taken away from the filter area and stored
- In order to return the filter to regular operation, follow the First Start-up Operation instructions as detailed in your user manual.
- For filters used in potable water systems it is required to disinfect the filter according to the local water authority standards and regulations before putting it back to service.

DIMENSIONAL DRAWING

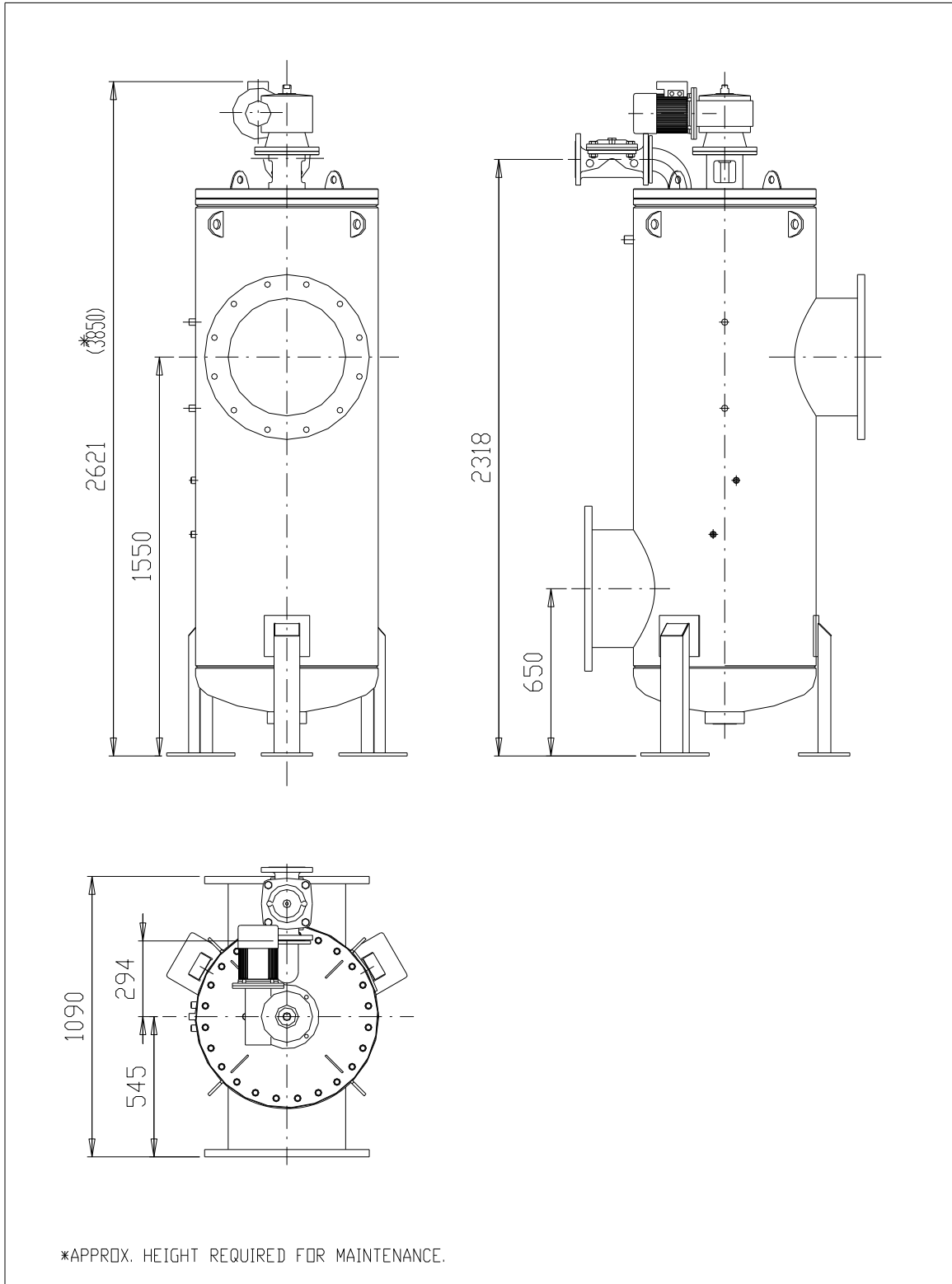

DESCRIPTION OF FILTER OPERATION

The automatic ABF-15,000 electric filter is a heavy duty, On-Line filter, which has built in automatic self-cleaning features to maintain and clean the filter screen during operation. The filter is designed to achieve filtration from 3500 micron to 200 micron through varying the filter screen size. The ABF-15,000 filter is available in sizes ranging from 14" to 20".

The automatic self-cleaning operation is monitored by the PDS (Pressure Differential Switch) that senses the pressure drop between the inlet and the outlet of the filter. The PDS is factory preset to start the flushing cycle at 0.5 bar (7 PSI) pressure differential.

Cleaning Process:

When the pressure drop between the inlet and the outlet of the filter reaches the preset value, cleaning of the filtration cylinder is operated automatically.

This operation consists of opening an exhaust valve (#14) located on the housing lid and starting the electric motor (#20) which revolves two stainless steel brushes (#7) on the inside of the filtration cylinder (#6).

The particles trapped on the cylinder are dislodged by the revolving brushes and flushed out through the open exhaust valve (#14).

The cleaning operation duration is approximately 15 seconds. The service flow of the filtered water is continuous during the cleaning cycle.

The electric board that is supplied with the filter controls automatic operation.

Stages of Flushing Cycle:

1. The P.D. Switch sends a signal to the electric board when 0.5 bar (7 PSI) pressure differential has occurred.
2. The exhaust valve opens to the atmosphere.
3. The motor starts rotating the shaft (#7) with the brushes for approximately 15 seconds.
4. The exhaust valve closes.

Through the self-cleaning process there is no interruption of flow, and the PDS is constantly monitoring the pressure differential between the inlet and outlet of the filter.

INSTALLATION AND START-UP INSTRUCTIONS

Mechanical Considerations

1. Select a convenient location for the installation of the filter where operation and maintenance will be optimum.
2. It is recommended to prepare a beam or any other arrangement, which will allow hanging a crane for opening the filter.
3. Install the filter vertically. Please note that a minimum clearance of 700 mm (28 In.) is required in order to allow disassembly of the unit.
4. Make sure that the direction of the flow is as indicated by the arrow marked on the filter housing. (Flow outlet will always be from the side; flow inlet is from the bottom).
5. If possible, prior to installing the filter, flush the main line, at the connection point thoroughly, in order to remove large objects, this may damage the filters internal mechanism.
6. Connect a 3" drainage pipe to the exhaust valve (#14). The maximum length of the drainage pipe will be 40 meters (120 feet). Please note, that no restriction is allowed on the drainage pipe. For special applications, please consult the manufacturer.

Electrical Considerations

1. Connect the appropriate electrical power supply to the control board and the interconnections between the control board and the electrical components on the filter, according to the wiring diagram provided.
2. Install fuses as noted on the electrical schematic and ensures that all electrical connections are well insulated.
3. The electrical wires (conduit) connecting the control board and the filter should be of sufficient length to enable disassembly of the drive unit from the lid without disconnecting these wires.

Start-up Considerations

1. Switch on the main circuit breaker.
2. Press the "TEST" push-button and check the direction in which the motor is rotating. The motor should rotate the brush shaft clockwise. If it is rotating in the other direction - change the direction by swapping the phase connections.
3. Slowly open the valve at the inlet of the filter. If possible with an outlet valve closed and a by-pass valve open, and repeat a manual flushing.
4. Open the outlet valve gradually and bring the filter to normal working condition.
5. Check that the PDS is properly functioning by draining its low-pressure tube. Draining is done by means of the 1/4" valve. Closing the valve for at least 3 seconds will cause the PDS to send an electric signal to the control board and automatic cleaning will begin.
6. The cleaning operation should be for 15 seconds and full flow out of the exhaust valve should be observed during this entire period. After the 15 second cleaning operation, the flow out of the exhaust valve should stop immediately. Be sure to observe that there is no significant leakage occurring from the exhaust valve once the cleaning operation has completely stopped.

ELECTRICAL CONTROL SYSTEM DESCRIPTION

The **ABF-15,000** control board monitors and operates the filter self-cleaning process. The self-cleaning process includes simultaneous operation of the motor and opening of the exhaust valve. The control board will cause the initiation of a flushing cycle as a result of each of the following reasons:

1. Signal from the **PDS**.
2. Manual initiation by **TEST / RESET** push-button.
3. Internal timer, up to 30 hours.

During operation condition the Main switch, the Motor Protector and the **F2** Circuit Breaker must be "**ON**". In this condition the power pilot light is lit.

Flushing by PDS:

The signal duration from the **PDS** should be longer than the preset time in timer **T0**. It is recommended to set it to 3-5 seconds.

This delay will prevent the filter from entering into flushing mode as a result of a momentary signal from the **PDS**.

Manual Operation:

Quick pressing on the **TEST / RESET** push button initiates self-cleaning.

Flushing according to Time:

The timer is located inside the control board and is marked "**T2**". It is possible to set it for intervals from a few minutes up to 30 hours.

To cancel the option of flushing by timer, turn off the **SW-1** switch.

Timer T1 determines the minimum flushing duration. It is recommended that flushing duration be set to 15 seconds.

Fault Mode:

The control board is equipped with a protection circuit. It will cause the filter to enter a "fault" mode if continuous signal from the **PDS** is received for duration longer than the preset time in **TAL**. This means that in case that the filter does not manage to clean itself, the **PDS** will continue to send a signal. When the **TAL** time elapses, flushing stops, "fault" pilot light is lit and fault relay is activated. It is possible to use this relay also for an alarm, automatic by-pass, etc.

To come out of fault mode, press the **TEST / RESET** push-button.

The recommended preset time for **TAL** is 5 minutes.

It is possible to order control boards with additional features such as sequential operation of a few filters in a battery, flushing counter, etc.

Follow the drawing in this manual for proper wiring of the control board to the filter.

DISASSEMBLING THE "ABF-15,000" FILTER

1. It is highly recommended to initiate a cleaning cycle prior to the filter disassembling.
2. Close the inlet/outlet valves and drain the filter.
3. Cut off the electrical power.
4. Disconnect electrical cables from the drive unit (#20), unless the cables are long enough and allow the motor to be removed without disconnecting it.
5. Disconnect the flushing pipe from the Exhaust Valve (#14)
6. Pull the electrical plug from the solenoid valve. (#13)
7. Remove Pilot Tube
8. Unscrew the bolts (#14.1) and remove exhaust valve (14).
9. Unscrew Bolts (#21) and remove the drive unit and the shaft key (#20)
10. Unscrew the housing bolts (#11) and pull the lid (#10) using a crane or other lifting device, which is assembled, exactly above the lid center.

Note: the lid must be removed in a horizontal position in order to prevent damage to the shaft and the screen seal.

11. Pull the Brush Assembly (#7) out from the screen (#6). Inspect the brushes and replace if necessary.

RE-ASSEMBLING THE "ABF-15,000" FILTER

1. Before reassembling, visually check that all components are complete and in good mechanical condition.
2. Install the seals (#6.1) on the screen (#6) and insert the screen into the filter housing (#1).
3. Insert the Brush Assembly (#7) in a spiral motion into the Screen Cylinder. Make sure the lower side of the spindle shaft will go through bearing (#4).
4. Locate the housing O-ring (#2) properly in its groove.
5. Lower the filter lid (#10) carefully toward the filter housing (#1) in a horizontal position. The Spindle upper Shaft should go through the center hole of the lid.
6. For centering the lid properly use two bolts (#11) in opposite positions.
7. Tighten the Lid Bolts (#11) in a balanced and even manner.
8. Place the Shaft Key (#7.1) in its place, apply some grease on the shaft and install the Drive Unit (#20)
9. Tighten all bolts and nuts to ensure proper position and sealing.
10. Re-connect the power cables
11. Switch the power on
12. Press the TEST push-button and make sure that the filter is working properly
13. Gradually, turn on the water, watch and eliminate any leaking

MAINTENANCE

General inspection

To check the proper operation of the filter, close the 1/4" valve for about 5 seconds thereby initiating the self-cleaning cycle: Check that the exhaust valve opens, the motor is moving and the brushes shaft is rotating.

Weekly maintenance

1. Check that the filter operates properly, following a general inspection.
2. If necessary, take care of any leakage from the spindle shaft by changing the O-rings (#8.1 & #8.2)

Annual maintenance

1. Check the integrity of the screen unit.
2. Check the internal coating for chips or scratches.

Maintenance prior to long term cessation of filter operation

The following must be done if the filter will not be in operation for more than a month.

1. Operate a flushing cycle (If possible, with a closed downstream valve).
2. Disconnect the control board from the power supply.
3. Release pressure from the filter.

Maintenance prior to re-operation

1. Change the shaft sealing O-ring (#8.1 & #8.2).
2. Connect the control board to the mains.
3. Check proper operation of the filter.

PARTS SCHEDULE

No.	Description	Cat. No.	No.	Description	Cat. No.
1	Filter Housing	710105-XXXXX	15	L-Connector 3/4" (Galvanized)	780101-000789
2	Housing O-Ring P2-392	770102-000165	16	3/4" Ball valve	730104-000223
3	Screen base	700190-003401	17	3/4" Control Filter 0.2 mm	010000-000042
4	Lower Bearing	710103-001930	17.1	Raccord nut 3/4"	710103-002570
6	Wedgewire Filter Cylinder	700101-XXXXXX	17.2	O-Ring P2-112	770102-000082
6	Perforated Filter Cylinder	700101-XXXXXX	17.3	Raccord nipple 1/4"	710103-002569
6.1	Cylinder Seal	770104-000077	18	P.D. Switch (Midwest)	720104-000028
7	Spindle and frame	710102-000508	18.1	L-Connector 1/8" x 5/16"	720501-000204
7.1	Key	710103-001925	18.2	L-Connector 1/4" x 5/16"	720501-000202
7.2	St. St. brush (x3)	710103-001888	18.3	Connector 1/8" x 5/16"	720501-000213
7.3	M6 X 30 St.St Bolt. (x18)	760101-000604	18.4	Connector 1/4" x 5/16"	720501-000206
7.4	M6 St.St. Washer (x18)	760103-000094	18.5	Electrical junction box	700190-002568
7.5	M6 St.St Nut. (x18)	760102-000085	18.6	Instrumentation Bracket	710103-002659
8	Sealing Flange	710103-002612	19	Three-way valve 1/4"	730104-000202
8.1	O-Ring 38 X 4	770101-000055	19.1	Pressure Gauge 1/4"	720301-000044
8.2	O-Ring 30 X 4	770101-000053	19.2	Manometer Valve 1/4"	730104-000196
9	2" Plug	780101-000779	19.3	1/4" T Connector F x F x M	720501-000214
10	Filter Lid	710105-XXXXXX	20	Drive Unit	720201-000026
11	M22 X 60 Galvanized Bolt. (x24)	760101-000373	20.1	Electric Motor (1.5 HP)	720202-000009
11.1	M22 Galvanized Washer (x24)	760103-000079	20.2	Gear 1:100	720203-000011
12	3" Flange seal	770103-000046	20.3	Gear Cover	710102-000678
13	Solenoid Valve (GEM-SOL)	720103-000177	20.4	M10 X 50 Socket Screw (x 2)	760101-000527
13	Solenoid Valve (ASCO)*	720103-000182	20.5	M10 St.St. Nut	760102-000087
13.1	L-Connector 5/16" x 1/4"	720501-000202	20.6	M10 St.St. Nut	760102-000087
13.2	Air-brake tube 8 mm (5/16")	720502-000022	21	Bolt M10 x 40 [x4]	760101-000314
13.3	Connector 1/4" x 1/4" (Brass)	710103-000591	21.1	Washer 3/8" [x4]	760103-000067
13.4	L-Connector 5/16" x 1/4"	720501-000202	21.2	Washer 3/8" [x4]	760103-000067
13.5	Air-brake tube 8 mm (5/16")	720502-000022	21.3	Spring washer M10 [x4]	760103-000086
13.6	L-Connector 5/16" x 1/4"	720501-000202	21.4	Nut M10 [x4]	760102-000064
13.7	Connector 5/16" x 1/4"	720501-000206	22	Coupling Unit	700190-002243
14	3" Exhaust valve (RAF)	730103-000519	22.1	Key (8mm x 10mm)	710103-001935
14	3" Exhaust valve (GAL)	730103-000521	22.2	Coupling Upper Part	710105-000898
14	3" Exhaust valve (RAM)	730103-000532	22.3	Isolation Flange	710103-001937
14.1	M16 X50 Galvanized Bolt (x4)	760101-000326	22.4	Coupling Lower Part	700190-002248
14.2	5/8" Galvanized Washer (x4)	760103-000069	22.5	St.St Allen Bolt M10 x 40 (x6)	760101-000526
14.3	5/8" Galvanized Washer (x4)	760103-000069			
14.4	M16 Galvanized Nut (x4)	760102-000067			

Catalogue Number might differ to filter diameter, flange standard or electricity specifications.

PARTS DRAWING #1

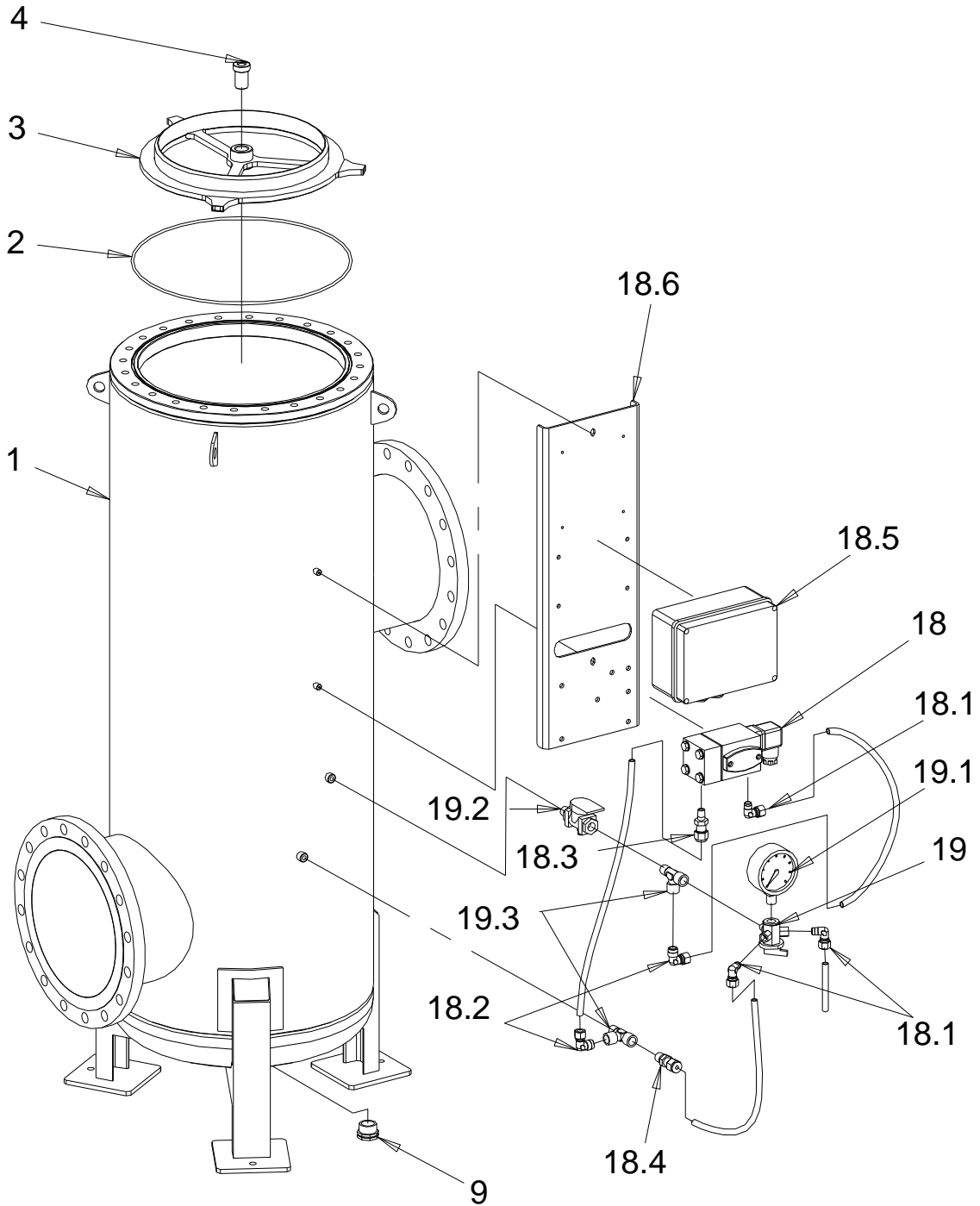

PARTS DRAWING #2

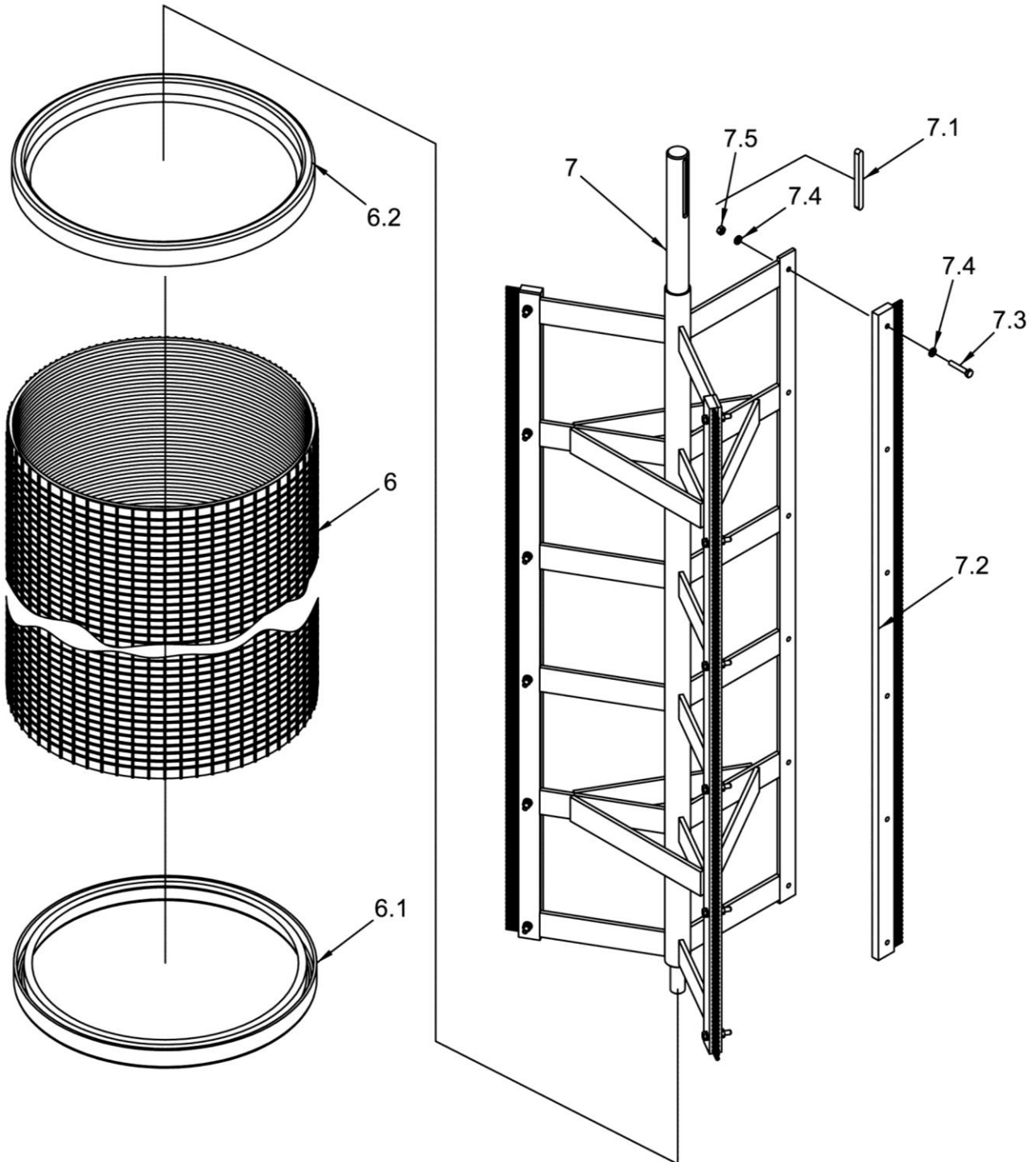

PARTS DRAWING #3

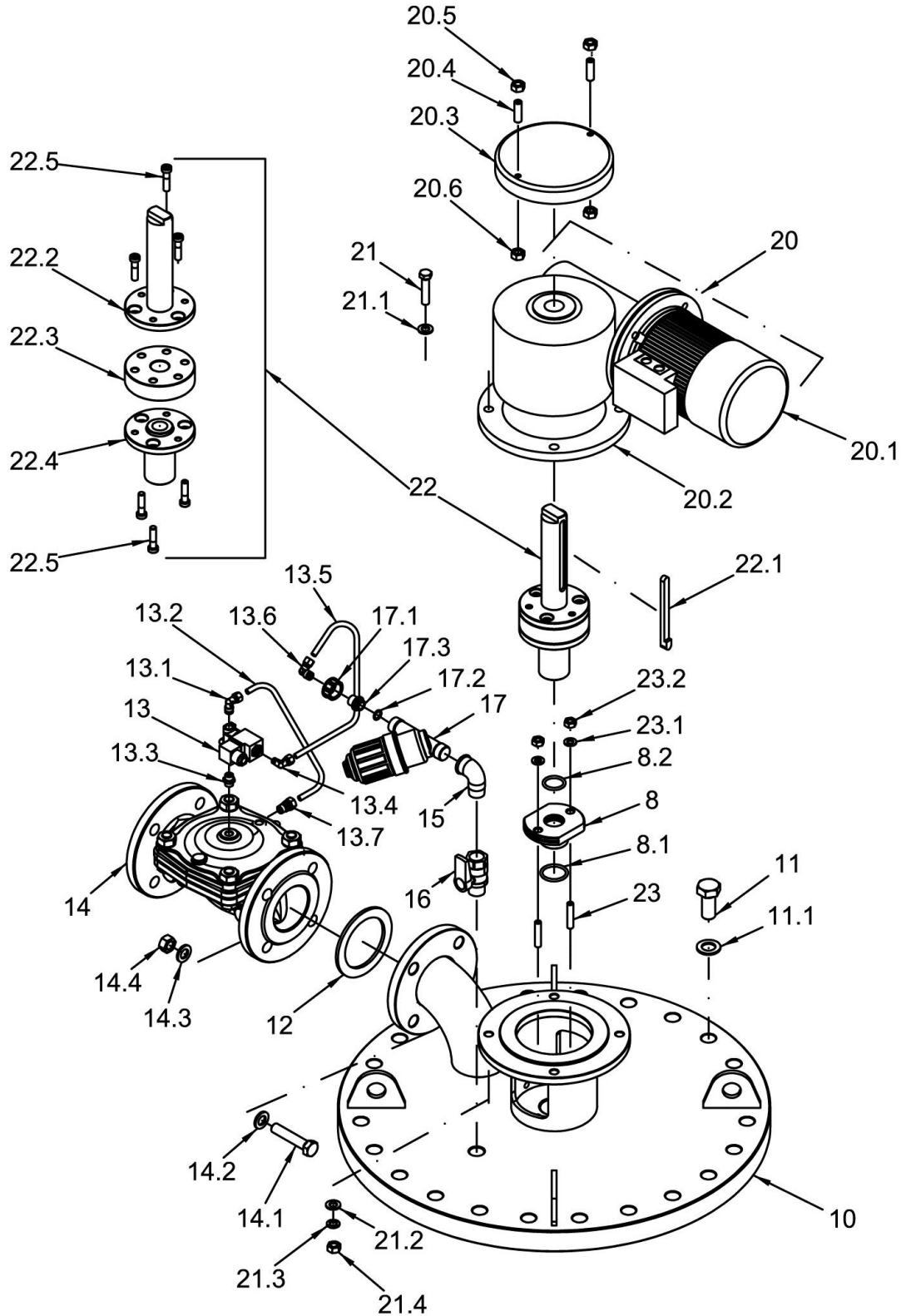

Amiad Limited Warranty

This certificate applies to Amiad Products purchased by You from Amiad or an Amiad authorized Distributor (“**Distributor**”). This limited warranty extends only to the original purchaser, and is not transferable to anyone who subsequently purchases, leases, or otherwise obtains the Product from the original purchaser.

1. Amiad hereby warrants that the Products are and will be free from defects in material and workmanship under normal use and service. Amiad warrants that it will correct manufacturing defects in the Products, in accordance with the conditions set out in this warranty.
2. This warranty is enforceable for a period of 12 months after the date Bill of Lading or equivalent (the “**Warranty Period**”).
3. In the event that during the Warranty Period the Distributor discovers a defect in material and/or workmanship in any Product or part (the “**Defective Product**”), it shall submit a written complaint to Amiad using Amiad’s standard customer complaint form. For the receipt of the customer complaint form, the submission of the complaint or any questions please contact your customer service representative.
4. Upon written demand by Amiad the Distributor shall return the Defective Products – or a sample thereof – to Amiad, at Amiad’s cost. If the customer ships any such Product, Amiad suggests the customer package it securely and insure it for value, as Amiad assumes no liability for any loss or damage occurring during shipment. Provided however that in the event Amiad determines that the warranty does not apply to such Product, Distributor shall promptly reimburse Amiad for such cost (including freight and customs). Any returned Product or part must be accompanied by the warranty certificate and the purchase invoice. It is clarified that the Distributor may not return the Defective Product unless such return was coordinate and approved by Amiad in advance.
5. Amiad’s obligation under this warranty shall be limited to, at its option, the repair or exchange, free of charge, of the Product or any part which may prove defective under normal use and service during the Warranty Period. The provision of a repaired or replacement Product during the Warranty Period will result in an extension of the Warranty Period by an additional period of 12 months, provided that the total accumulated Warranty Period shall in any event be no more than 18 months from the original Bill of Lading.
6. This warranty is valid on the condition that the Products are installed according to Amiad’s instructions as expressed in Amiad’s instruction manuals and according to the technical limitations as stipulated in Amiad’s literature or as stated by a representative of Amiad.
7. This warranty will not apply to damaged or defective Products resulting from or related to:
 - (i) Fire, flood, power surges or failures or any other catastrophe/and or unforeseen occurrence, such as but not limited to those for which the customers are customarily insured;
 - (ii) Fault, abuse or negligence of the customer;
 - (iii) Customer’s responsibilities, including the failure of the intake water to meet the agreed standards, as set forth in a written document, approved by Amiad or improper storage.
 - (iv) Improper or unauthorized use of the Product or related parts by the customer, including the customer’s failure to operate the Product in conformity with the recommendations and instructions of Amiad, as set forth in Amiad’s manuals and other written materials, the operation of the Product other than by a trained and qualified operator, or improper installation of the Product by a third party not authorized by Amiad;
 - (v) Performance by the customer of maintenance and other services other than by a trained and qualified advanced operator, or other than in conformity with the recommendations and instructions of Amiad, or other than in accordance with procedures defined in the literature supplied for Products;
 - (vi) Any alteration, modification foreign attachment to or repair of the Products, other than by Amiad or its authorized technical representatives.
8. In no event shall Amiad be liable to the customer or any third party for any damages, including indirect, special, exemplary, punitive or consequential damages, or lost profits arising out of or in connection with this warranty, or arising out of or in connection with the Product’s performance or failure to perform, even if it has been advised of the possibility of such damages.
9. Amiad will be excused for failure to perform or for delay in performance hereunder if such failure or delay is due to causes beyond its reasonable control or force majeure preventing or hindering performance.
10. The limited warranty set forth herein is the only warranty given by Amiad and is provided in lieu of any other warranties created by any documentation, packaging or otherwise.
11. Amiad makes no warranty whatsoever in respect of accessories or parts not supplied by Amiad. In the event that Amiad is required to correct a defective Product or product not covered by this warranty, it will do so solely in consideration *for additional fees*.



Amiad Water Systems Ltd. D.N. Galil Elyon 1, 1233500, Israel.

Tel: +972 4690 9500 | Fax: +972 48141159 | Email: info@amiad.com

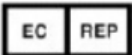

Obelis s.a. Bd Général Wahis 53, 1030 Brussels, Belgium.

Tel: +(32) 2732 5954 | Fax: +(32) 27326003 | Email: mail@obelis.net

EC Declaration http://amiad.com/pdf/certificates/MACHINERY_SAFETY.pdf